



## The item Automation System

Comprehensive Catalogue

3.1

# The item Automation System - everything slots into place

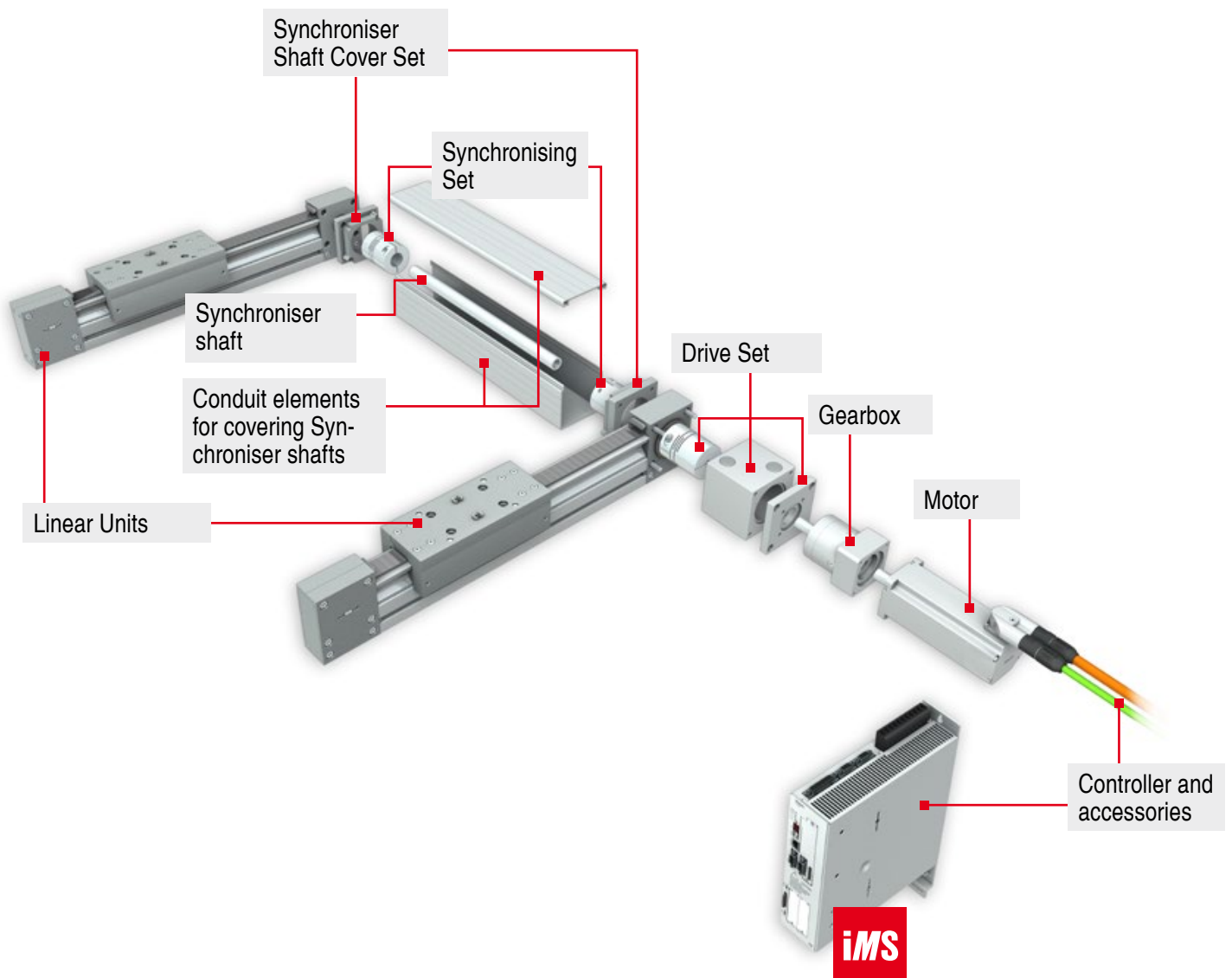



### **Selection – get the ideal Linear Unit every time**

Rapid movement, powerful lifting, precise positioning – no matter what your application is, the item Automation System can provide optimised linear technology with a suitable drive type.

- Large selection of Linear Units for moving even heavy workpieces
- Suitable for use in harsh environmental conditions
- Automation solutions with very long stroke lengths can be achieved

### **Teamwork – coordinated components for your all-in-one solution**

One principle, unlimited possibilities. Thanks to the modular principle of the item Automation System, all components work together seamlessly.

- Numerous plug-and-play solutions for Motors, Gearboxes and Controllers
- Support for connecting to custom motors and controllers
- Easily retrofittable synchronisation for Linear Units

### **Software – help with design and selection**

High speed or high torque? item MotionDesigner® calculates the perfect combination of all components to suit your transport task precisely.

- Maximum certainty when selecting components, because everything fits together
- Expert know-how integrated into the software supports the design process
- You retain a full overview of all the details

### **Service – preconfigured and ready-to-install automation solutions**

Made specifically for you – all item Linear Units are delivered so you can get started straight away. Commissioning can be completed in next to no time when using Motors and Controllers from item.

- The all-in-one system means there is no need to have in-depth knowledge about all the components
- Self-testing and automatic Controller setting with item MotionSoft®
- Service and support are available from item at all times

# Contents



## Linear Units

---

Linear Units with a timing-belt drive	19
Linear Units with a ball screw drive	45
Linear Units with a chain drive	54
Linear Units with a rack drive	57



## item MotionKits

---

item MotionKits Linear Unit KGT	64
---------------------------------	----



## Drive elements

---

Plug-and-play Drive Sets	68
Universal Drive Sets	79
Synchronising Sets	92
Tubes for Synchronising Sets	98
Synchronising Shaft Profile	99
Accessories for Synchronising Shaft Profile	100
Synchroniser Shaft Cover Sets	102
Conduit and Lid Profiles	105



## Gearboxes

---

Axial planetary Gearboxes	109
Bevel planetary Gearboxes	113



## Motors

---

Motors SE	119
-----------	-----



## Controllers

---

Controller BL	127
C 1 Controllers	129
C 3 Controller	130
Safety Module STO	131
Fieldbus interfaces	132
Cables	133
Shield Terminal Block D14	137



## Accessories

---

Linear Guides 6 60 PS	140
Carriage Plates and Transverse Carriage Plates	141
Profile Fastening Set 6/8 80x60	143
Slide Stop LRE 8	144
Proximity Switches	145
Proximity Switch Sets	148
I/O Interface Module (C Series)	150
Pin Spanners	151
Track Oil / Oil Can for Linear Guides	152



## Technical data

---

Nomenclature of product names	154
Linear Units	160
Gearboxes	174
Motors	176
Controllers	178



## Other item product lines

One principle, unlimited possibilities. The item product lines can be easily combined and used alongside each other. For instance, compatible components and adapters ensure that a frame built using profiles from the MB Building Kit System can be used with Profile Tubes from the Lean Production Building Kit System on a bench from the Work Bench System. Separate catalogues can be downloaded or ordered for the various product lines.

item reviews and extends its product range on a regular basis. You can always find all the latest information on new and existing products on our website: [item24.com](http://item24.com)

### MB Building Kit System

The item MB Building Kit System is the solution for all design and construction tasks involving factory equipment engineering. It can be used to build everything from simple frames to fully automated production lines. The modular components are the basis for profile frames, racks, enclosures, guards and electric and pneumatic solutions. Universal fastening and opening elements enable users to build doors, hatches and solid panels. Reliability and extendibility ensure that all constructions have a long useful life.

### Work Bench System

The item Work Bench System makes manual production in industrial environments more productive. Everything centres on robust, height-adjustable work benches that can be extended with Uprights, Pivot Arms and picking solutions. Meanwhile, conveyor lines and SystemMobile supply trolleys help move materials from A to B. The end results are versatile and adaptable solutions for production, assembly and laboratory applications. The item Work Bench System is the first complete system to carry the AGR seal of approval for its end-to-end ergonomics.

### Lean Production Building Kit System

Optimised for lean production. Aluminium Profile Tube System D30 is a speedy solution for building cost-effective factory equipment such as stable racks, transport trolleys and workstations. Entire logistics solutions with integrated roller conveyors can be constructed on site and continuously adapted and extended. Mechanical automation systems that don't need complex and costly drives or sensors provide an extra boost for productivity. Thanks to the long-lasting hold of the fasteners, running and maintenance costs are lean, too.



[item24.de/en/epaper-mb](http://item24.de/en/epaper-mb)



[item24.de/en/epaper-wbs](http://item24.de/en/epaper-wbs)



[item24.de/en/epaper-lp](http://item24.de/en/epaper-lp)



### All the information you need at your fingertips

item product catalogues are available online as clearly laid out and convenient e-papers. Take your pick and get browsing!

## Automation System

The item Automation System comprises high-performance, ready-to-install Linear Units. An item linear motion unit® consists of a Linear Unit, Motor, Gearbox and Controller. When using selection and design software item MotionDesigner®, all components can be customised to suit your application precisely. The turnkey system is delivered in the length required and is ready for use straight away. This reduces overall costs significantly. A wide range of different drive elements etc. is available to suit all requirements.



[item24.de/en/epaper-au](http://item24.de/en/epaper-au)

## Stairway / Platform System

The Stairway / Platform System is the specialist for building regulation-compliant bridges, safe maintenance platforms and all-round working platforms. As a result, staff can reach every corner of a machine or plant and work there safely. The solutions can be configured to suit the space available, with components used on a free-standing basis or seamlessly integrated into a machine frame. The end results are reliable and uniform stairways, guard-rails and platforms that satisfy all requirements in terms of ergonomics and safety.



[item24.de/en/epaper-tp](http://item24.de/en/epaper-tp)

## Online tools

Better than thumbing through catalogues, putting together drawings and carrying out calculations, software and online tools from item help you engineer custom solutions in record time. Intelligent configurators know the components inside out and the online tools ensure that everything comes together perfectly – from design through optimisation to commissioning. Digital engineering speeds up planning and coordination thanks to personal project memories, parts lists, CAD data and 3D PDFs. The online tools include the Engineeringtool, item MotionDesigner® and the Work Bench Configurator.



[item24.de/en/service/online-product-configurators](http://item24.de/en/service/online-product-configurators)



iF product design award



## Quality and design

Nothing is more important than reliability. That's why designers put their trust in products from item. We place a great deal of value on quality management throughout every stage of production. All our components pass through a thorough programme of testing before they can move on from the design stage. Existing product lines are also subject to repeated testing.

For item, good design means utilising physical principles to find the optimum technical solution. The result is a range of products that are both elegant and functional. And that is why item regularly wins top design awards.



# Lean production with the item online tools

## Software and support

To provide the best possible assistance for your process automation tasks, we offer both highly proficient support and a number of innovative software solutions that ensure automation applications can be realised simply and conveniently.

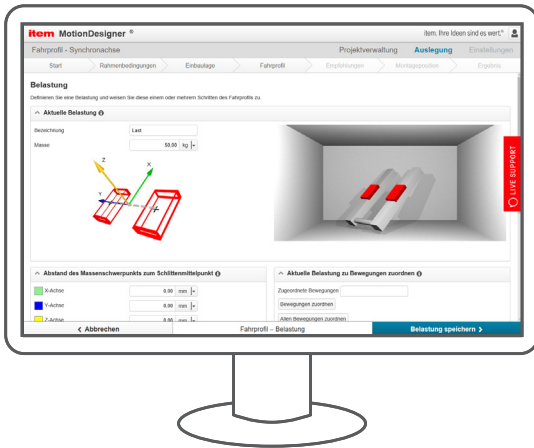

### item MotionDesigner®

item MotionDesigner® is completely free to use and analyses thousands of options to calculate the perfect combination of components for your specific task. At the end of the process, you get an optimised turnkey solution and a list of useful accessories that can be used with it.



### item MotionSoft®

item MotionSoft® is smart commissioning software that links up seamlessly with configurations produced in item MotionDesigner®. Data entered during the configuration process is reused, the optimum controller settings are automatically calculated, and the entire system can be autonomously checked if required.



### item Academy

Just-in-time learning! The item Academy shares knowledge through its online training units, step-by-step guides and instructional videos, which cover many different aspects of mechanical engineering and the item product world. This free online learning platform offers in-depth training courses and know-how for immediate use, covering topics such as automation, lean principles and value-stream mapping. The various modules and units differ in terms of how long they take to complete, their focus and technical detail. The content in the item Academy is available round the clock on the internet and in six languages: [academy.item24.com](http://academy.item24.com)



You can find all item online tools at:  
[item24.de/en/configurators](http://item24.de/en/configurators)

## Linear Units for all applications - from delicate to heavy duty

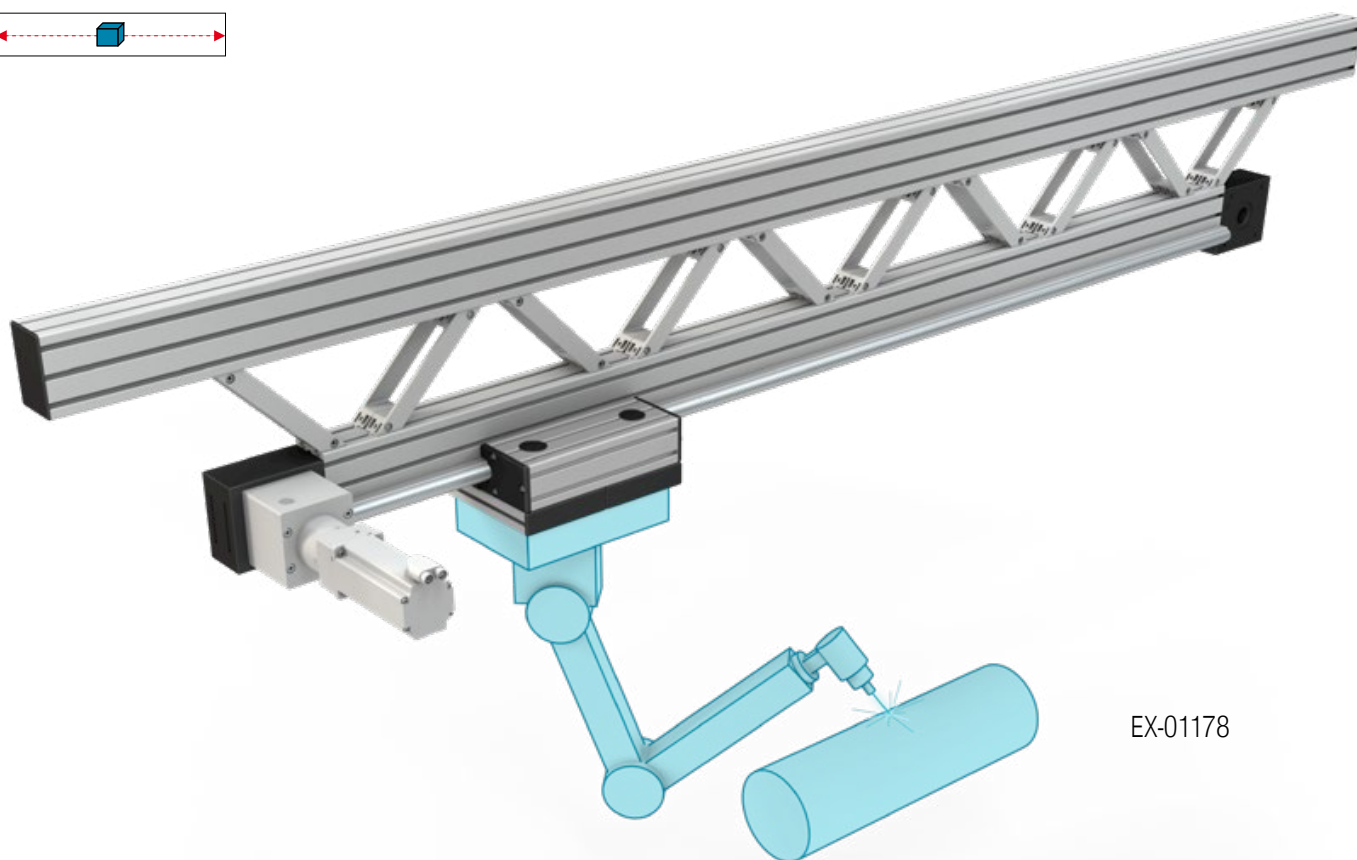
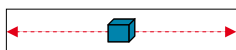

EX-01178

In automated systems, multiple worksteps are often carried out along a line. A Linear Unit is used to move either the workpiece to be processed or the tool – such as a robot – along this line so that screwing, drilling or joining can be carried out. Many different requirements are placed on this kind of solution, which may have to transport heavy loads or position itself with accuracy measured down to a fraction of a millimetre. Depending on the production process, it may be important for the solution to be resistant to soiling.

### The benefits of the item Automation System:

- 1) The particularly rigid linear guides deliver a high load-carrying capacity that can be increased further using elements from the MB Building Kit System.
- 2) The length of the linear axis is not limited by the length of a single profile. Many models allow users to extend the travel distance with almost no transitions.
- 3) The mounting arrangement of the Linear Unit can be selected to suit the task at hand because the stable guides also support angled and suspended applications.
- 4) Thanks to the large selection of linear drives, you can optimise your Linear Unit for any task and working environment.



**Note:** CAD data for the models depicted here is available to download from the item website.



## 2D flat gantries – using Linear Units in sync

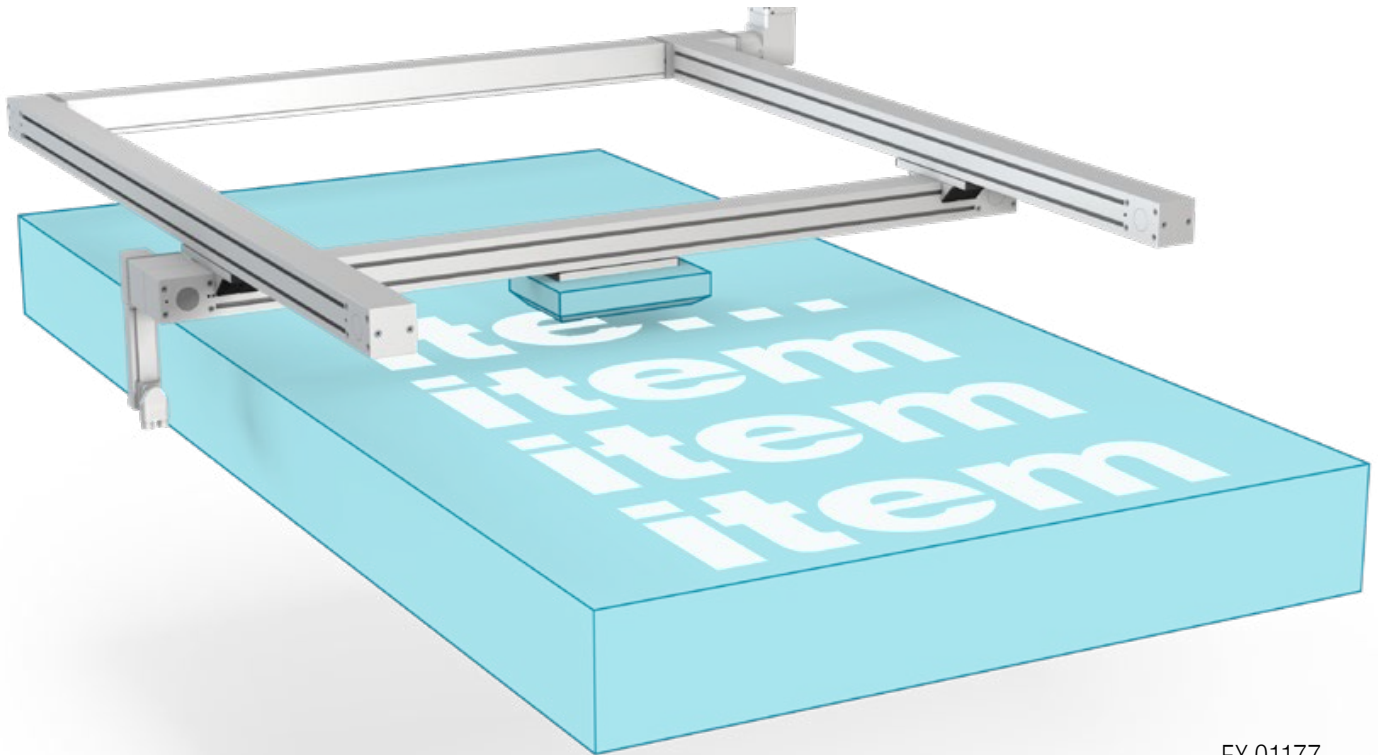
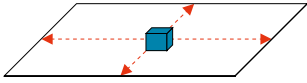

EX-01177

2D flat gantries are perfect for automation tasks in which a tool travels to various points in a single plane. These two-axis solutions are used to print or inspect surfaces, among other things. Tools such as styluses, sensors and print heads need to be moved with precision, often over large distances, which places stringent requirements on the rigidity and synchronous movement of the linear axes in two dimensions.

### The benefits of the item Automation System:

- 1) Long synchronising shafts in the item Automation System ensure 2D flat gantries can have a very wide working area.
- 2) Sturdy carriages ensure heavy tools can be reliably secured and moved over long stretches.
- 3) item MotionDesigner® can be used to design mechanically synchronised Linear Units and thus helps you find the ideal solution fast.
- 4) Linear Units with timing belts that are fed through the inside of the profile and roller guides that are concealed in the core of the profile feature optimum protection.

## 3D gantries – using three axes to reach any point in a space

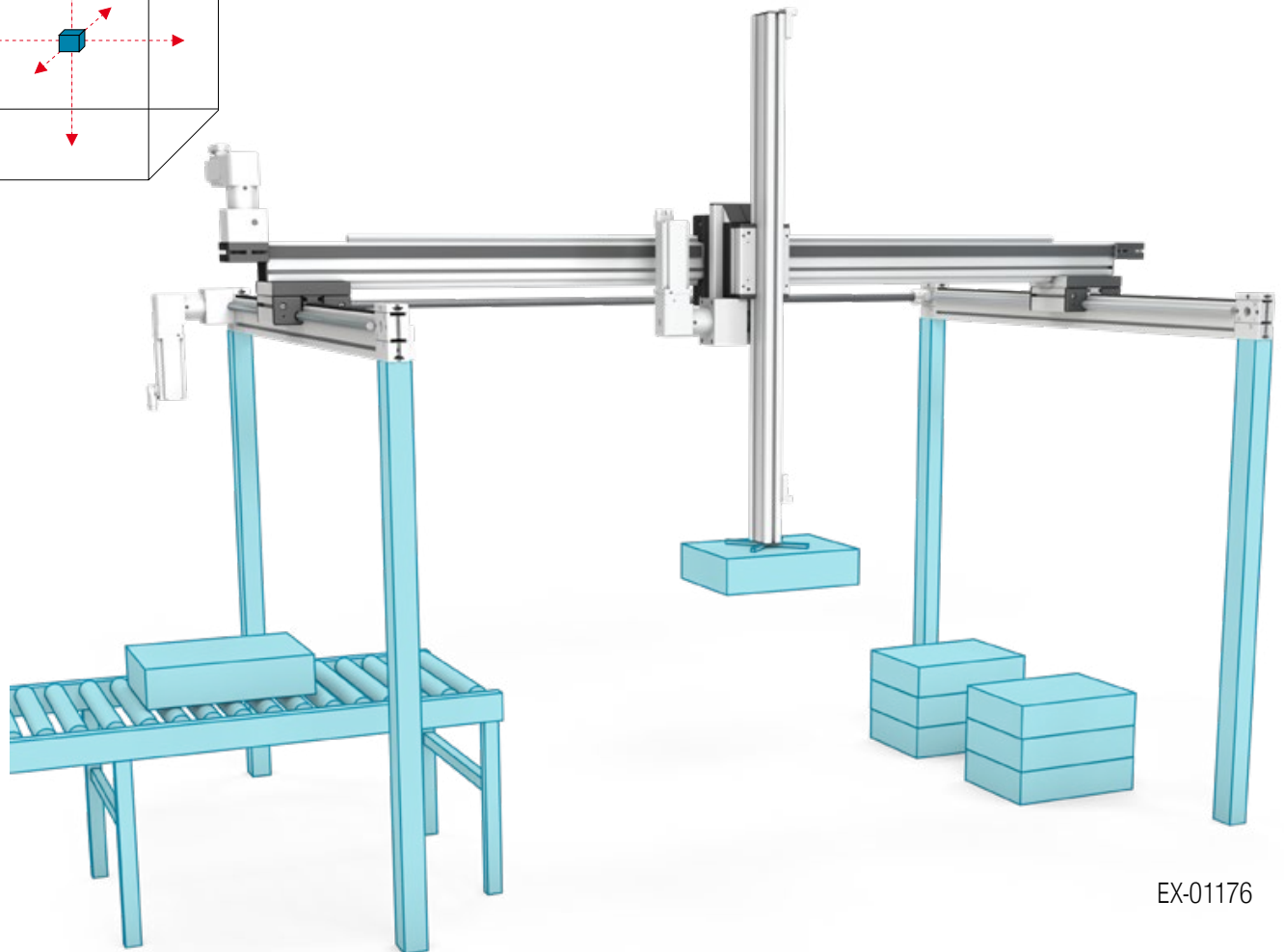
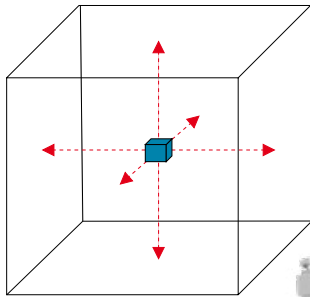

EX-01176

3D gantries carry out demanding positioning tasks in three dimensions. They are used to pick up, move and set down workpieces for stacking, sorting and machining operations. When designing pick-and-place systems, it is important, on the one hand, that the right grippers and tools for the task can be attached. On the other hand, the rigidity of the overall construction is crucial. This prevents load-related vibration on the Z axis and thus enhances the gantry's precision.

### The benefits of the item Automation System:

- 1) Thanks to the wide range of basic models, users are sure to find the perfect Linear Unit combination to optimise the speed, accuracy and load-bearing capacity of their 3D application.
- 2) Compatibility with the MB Building Kit System means the load-bearing frame can be adapted to the space available and the enclosure can be connected to other plants
- 3) To ensure loads and forces can be optimally distributed, the carriage plates of the Linear Units can be easily enlarged and thereby adapted to tools and workpieces.
- 4) Many item Linear Units can be extended beyond the profile length to cover a large working area.

## Cantilever axes - putting the support profile to powerful use

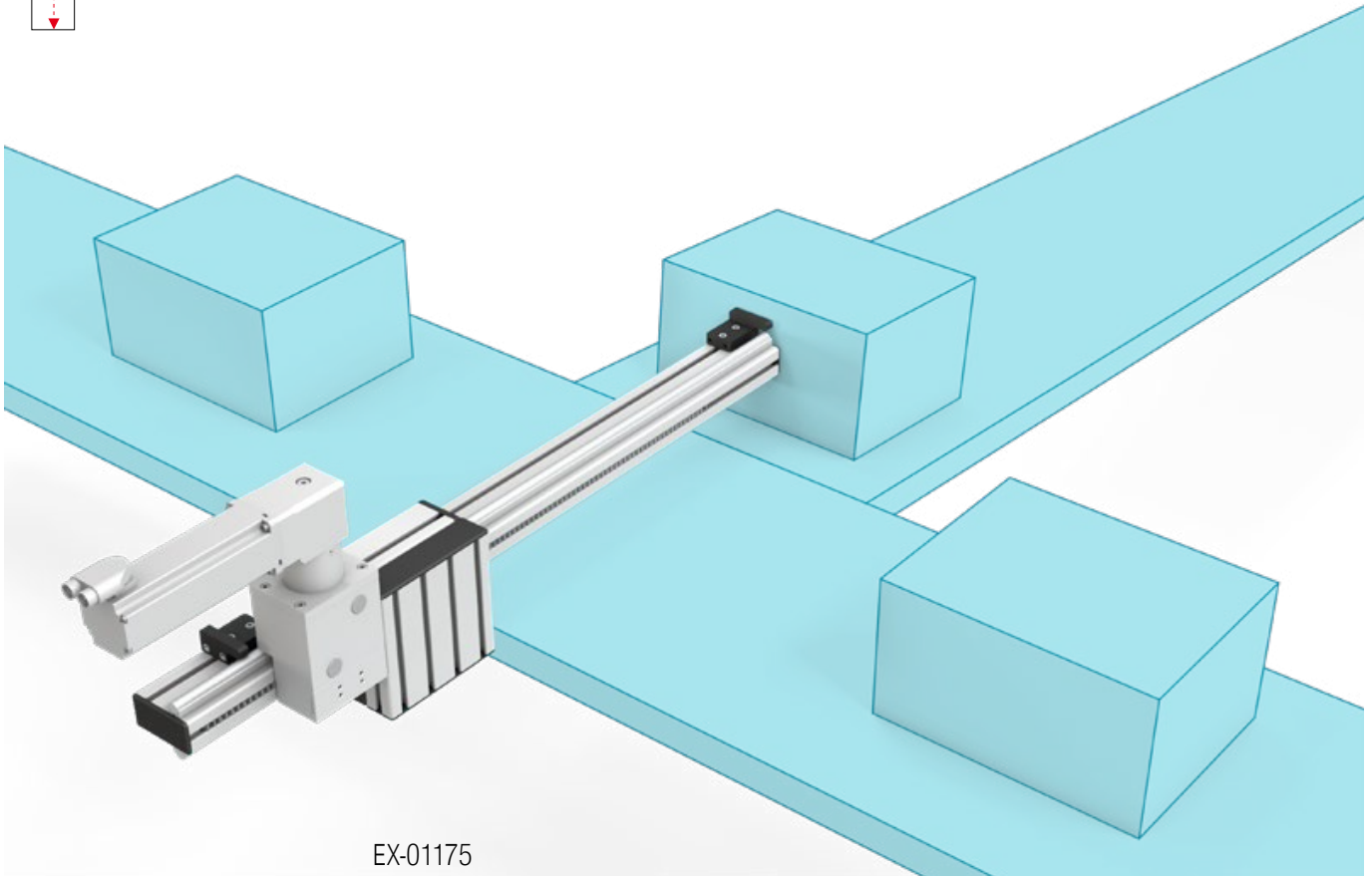
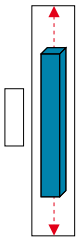

EX-01175

Cantilever axes use the support profile of the Linear Unit to exert force on a workpiece or to accurately position a tool. They are ideally suited for production and logistics tasks and also for many material and load tests. As the aluminium profile moves and the carriage remains stationary, this system can be used to select articles moving along a conveyor belt, for example. A cantilever Linear Unit has to accommodate high forces and torques, which the axis itself generates due to its movement and operating forces.

### The benefits of the item Automation System:

- 1) Compatibility with the MB Building Kit System means tools and applications can be easily and securely fastened to the support profile.
- 2) The length of the guide rail can be adapted to suit the task at hand precisely. This is possible thanks to highly robust guides and item racks, which can be implemented in custom lengths.
- 3) item MotionDesigner® keeps design and selection processes as simple as they are for conventional Linear Units by factoring in the loads associated with the cantilever.
- 4) item cantilever axes can be designed with lightweight support profiles for excellent dynamics or with heavy-duty profiles and robust racks for particularly high load-bearing capacity.

## XY tables - dynamic lifting and moving

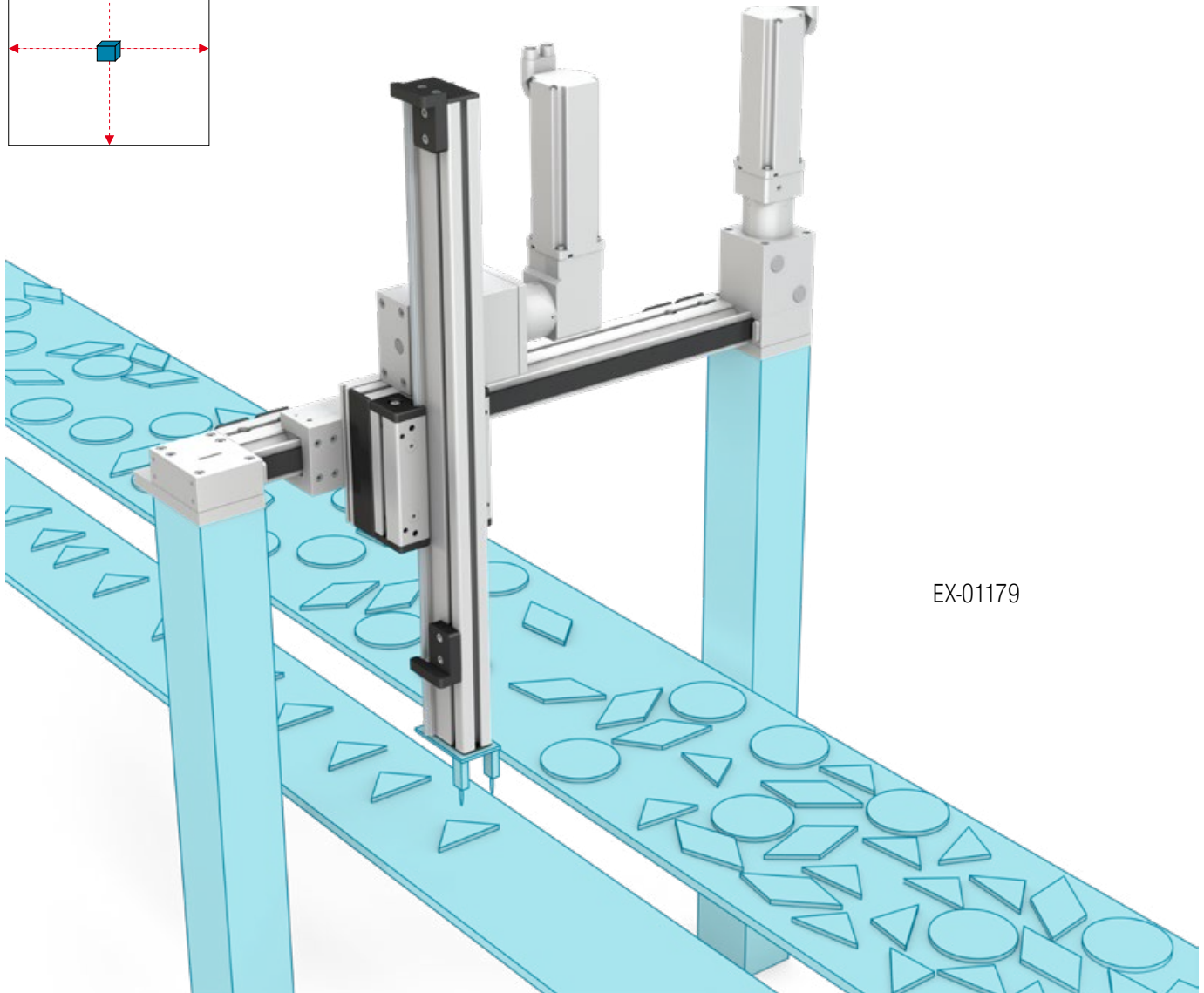
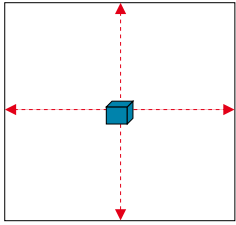

EX-01179

Grippers, suction cups, lasers and scanners are used in XY tables for machining, sorting, positioning and inspecting workpieces. The tool is often guided into place from above via a cantilever axis, while the X axis is used to move it to different positions. 2D linear gantries are perfect for dynamic pick-and-place tasks. Unlike 2D flat gantries, the working area of the tool can be adapted to the contour of the workpiece.

### The benefits of the item Automation System:

- 1) Even heavy tools can be guided across a wide working area in this way thanks to the low profile deflection and exceptional load-bearing capacity of the linear axes.
- 2) System grooves and compatibility with the item MB Building Kit System ensure the XY table can be easily integrated into a machine frame.
- 3) Proximity Switches and mechanical Limit Stops are available to ensure both axes can be operated safely.
- 4) The dimensions of the cantilever axis can be adapted very precisely to the task at hand so as to make economical use of the installation space.

## High-precision gantries – precise and dynamic operation

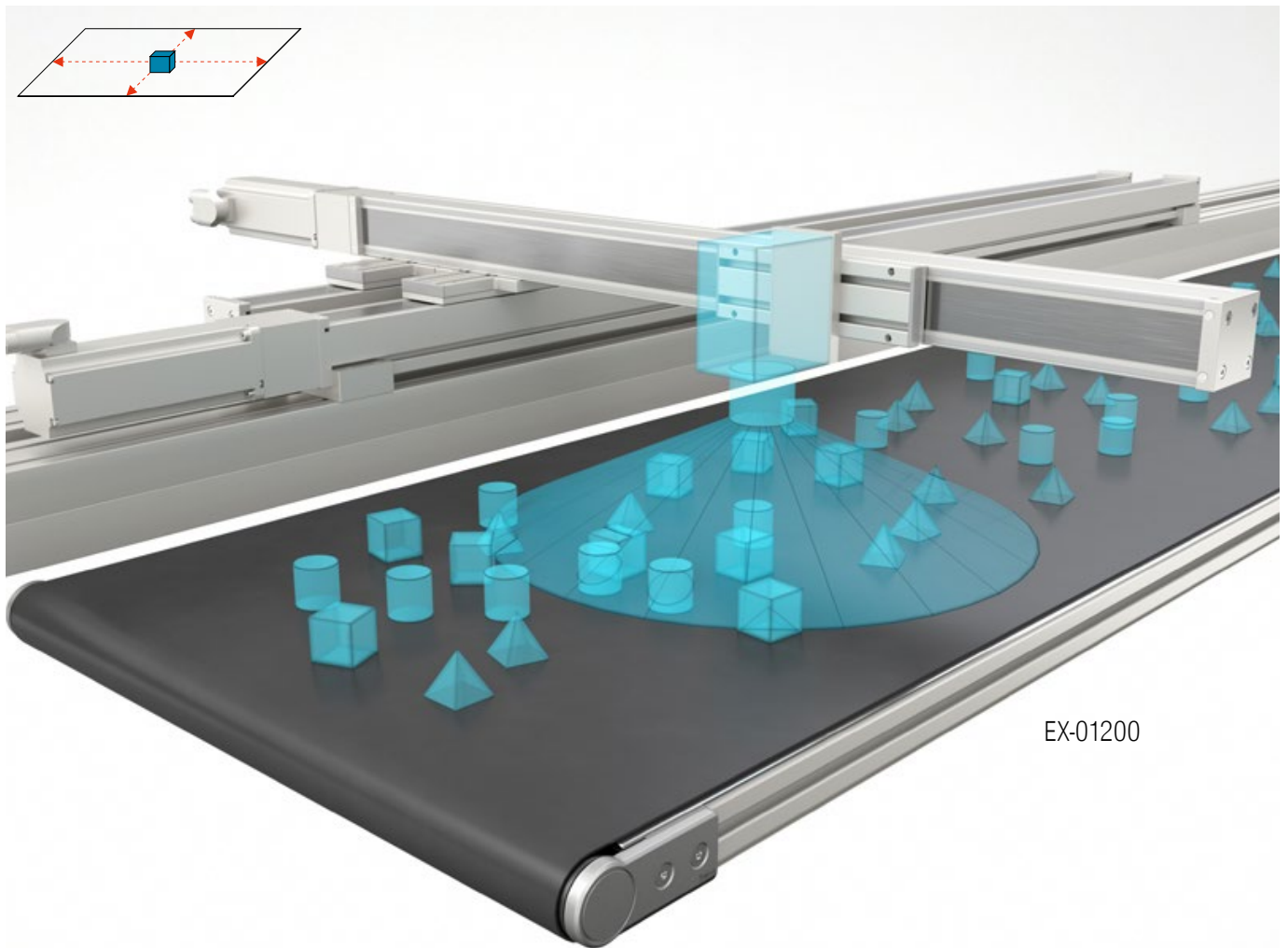

The combination of two Linear Units KGT 6 60 and one parallel supporting Linear Guide 6 60 enables highly precise and dynamic applications – even with a heavy tool or a long cantilever arm.

The two spindle axes each offer a stroke length of up to 2600 mm. The powerful ball screw drive accelerates at  $15 \text{ m/s}^2$ , thus ensuring that a camera, laser or measuring device can be used with precision at alternating coordinates. The carriages run on robust recirculating ball units.

### The benefits of the item Automation System:

- 1) Maximum precision is achieved on the x and y axis by using two Linear Units KGT 6 60 with a ball screw drive that have a repeatability of 0.01 mm.
- 2) Mechanical spindle supports in the encapsulated housing keep everything running smoothly, even during dynamic acceleration and braking of the cantilever arm and tool.
- 3) The Linear Guide that runs in parallel with the Linear Units ensures that a large reach can be achieved with low material usage because load is distributed over two torsion-resistant support profiles.
- 4) Self-centring fixings and compatibility with the item MB Building Kit System ensure the XY table can be easily integrated into a machine frame.



## item drive technologies

Installation-ready Linear Units from item: preconfigured linear technology that has been optimised for speed, payload, precision and stroke length.



Linear Units with a timing-belt drive

- Ideal for speed and reliability
- High drive forces and long travel distances



Linear Units with a ball screw drive

- Maximum precision and strong drive force
- Play-free and very strong



Linear Units with a chain drive

- Particularly resistant to dirt
- High force transmission and suitable for vertical movements



Linear Units with a rack drive

- Powerful stroke and precise control
- Non-slip power transmission



**Payload**

The item Automation System can also be used to move very heavy loads. item MotionDesigner® knows the technical data associated with all components such as the guide and support profile and calculates the optimum combination for your transport task, as suited to your installation scenario.



**Repeatability**

Linear Units are optimised for point-to-point motions. High repeatability means the carriage will stop precisely where it is supposed to. The item ball screw drive positions the carriage precisely, down to 0.05 mm.



**Speed**





Acceleration and high maximum speed keep work cycles short. When speed and long travel distances are the primary concerns, the best option is a timing belt. The item Automation System offers you the widest selection.



**Maximum travel distance**

Depending on the model in question, the ready-to-install Linear Units from item offer a stroke length of up to 6000 mm. Even longer travel distances can be implemented for special designs.

**Overview of ready-to-install Linear Units**

Linear Unit	Payload 	Speed 	Repeatability 	Maximum travel distance 
Linear Unit GSF 8 40 R10	█	█ █	█	█ █
Linear Units KLE	█ █	█ █ █ █ █	█ █ █ █	█ █ █ █
Linear Units KRF	█ █ █ █	█ █ █ █ █ █ █	█ █ █ █ █	█ █ █ █ █
Linear Unit LRE 5 D6	█	█ █ █ █	█ █ █ █ █	█ █ █
Linear Units LRE 8 D10	█ █ █	█ █ █ █ █ █ █ █	█ █ █ █ █ █ █	█ █ █ █ █ █ █ █
Linear Units LRE 8 D14	█ █ █ █ █	█ █ █ █ █ █ █ █	█ █ █ █ █ █ █	█ █ █ █ █ █ █ █
Linear Units LRE 8 D25	█ █ █ █ █ █ █ █	█ █ █ █ █ █ █ █	█ █ █ █ █ █ █	█ █ █ █ █ █ █ █
Linear Unit KGT 6 60 P20	█ █ █ █ █ █ █ █	█ █ █ █	█ █ █ █ █ █ █ █ █	█
Linear Unit LRE 8 D10 80x80 KGT 20x5	█ █ █ █	█	█ █ █ █ █ █ █ █ █ █	█
Linear Unit LRE 8 D10 80x80 KGT 20x20	█ █ █ █	█ █ █ █	█ █ █ █ █ █ █ █ █ █	█
Linear Unit LRE 8 D14 80x80 KGT 20x5	█ █ █ █ █ █ █ █	█	█ █ █ █ █ █ █ █ █ █	█
Linear Unit LRE 8 D14 80x80 KGT 20x20	█ █ █ █ █ █ █ █	█ █ █ █	█ █ █ █ █ █ █ █ █ █	█
Linear Unit LRE 8 D14 80x40 KU 80	█ █ █ █ █ █ █ █	█ █ █ █	█	█ █ █ █
Linear Unit LRE 8 D14 80x40 ZS	█ █ █ █ █ █ █ █	█ █ █ █	█ █ █ █ █ █ █ █	█ █ █ █ █ █ █ █
Linear Unit LRE 8 D10 80x40 ZS K	█ █ █ █	█ █ █ █	█	█ █ █ █ █ █ █ █

Note: You can find a detailed comparison of the technical data for all item Linear Units starting on Page 160.

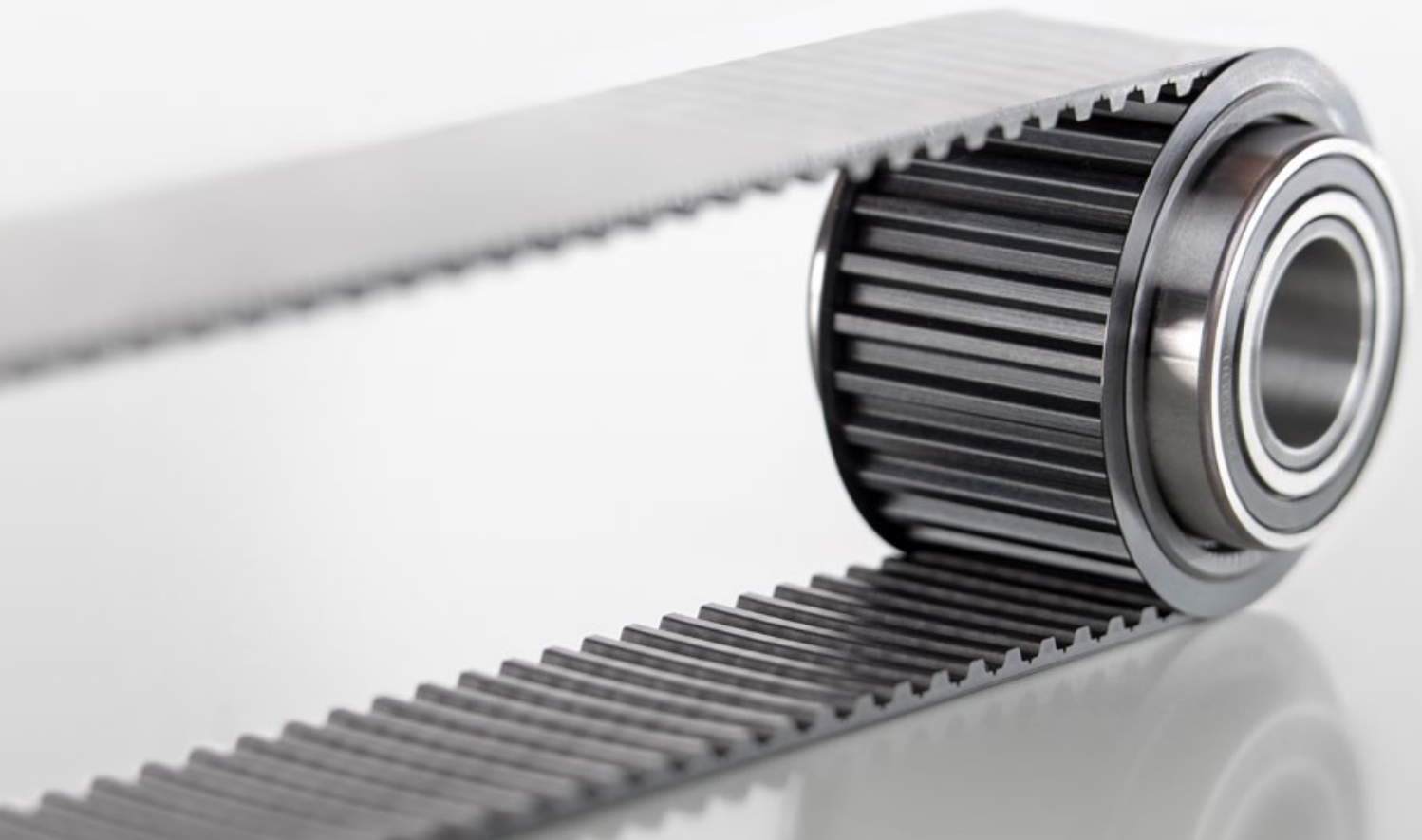

## Linear Units with a timing-belt drive

When speed and reliability are the primary concerns, the best option is a timing-belt drive. It supports extremely dynamic movements and therefore short cycle times.

In a timing-belt drive, a toothed drive belt locks mechanically around a toothed pulley that is driven by a motor. This mechanical interlocking eliminates slip and ensures high forces can be transmitted. The drive can also reverse its direction rapidly and accelerate large masses.

The timing belt comprises steel cables in a polyurethane sheath, has a long service life and supports a smooth running action. Because the belt itself has a low mass, it takes little energy to move it on its own.

Linear Units with a timing-belt drive can be built in virtually any length. As a result, they produce Linear Units that combine high drive forces with long travel distances. The drive effect is applied where the timing belt is reversed.

When using this type of drive in a vertical application, steps need to be taken to ensure the carriage does not run out of control if there is a power cut. Unless a motor brake is fitted, the timing belt can be easily moved and therefore does not hold its position independently.



## Linear Unit GSF 8 40 R10

- Low-cost, quiet, compact and low-maintenance
- Low-friction sliding guidance



Light, quiet and high-performance! Linear Unit GSF 8 40 R10 is an efficient turnkey system with minimal space requirements. This economic Linear Unit uses only a few components to deliver maximum performance. For example, the carriage uses a Line 8 groove on the support profile as its guide. It runs without lubricants on a wear-resistant sliding shoe.

The timing-belt drive and reverse unit also feature an exceptionally compact design. The tensioning device for the timing belt is integrated into the reverse unit. Its ball-bearing mounted pulleys ensure quiet and smooth running over long-term use. The timing belt is routed back through the profile groove.

The compact dimensions and maintenance-free design make Linear Unit GSF 8 40 R10 an exceptionally efficient solution. It is ideal for applications that require the movement of low loads. Thanks to the practical hollow shaft, an expanding hub coupling can be installed on the right or left, as appropriate to the installation scenario.

Note: Linear Unit GSF 8 40 R10 is supplied ready for installation as a turnkey system in the desired stroke length. The components can also be ordered separately and assembled to form customised units.

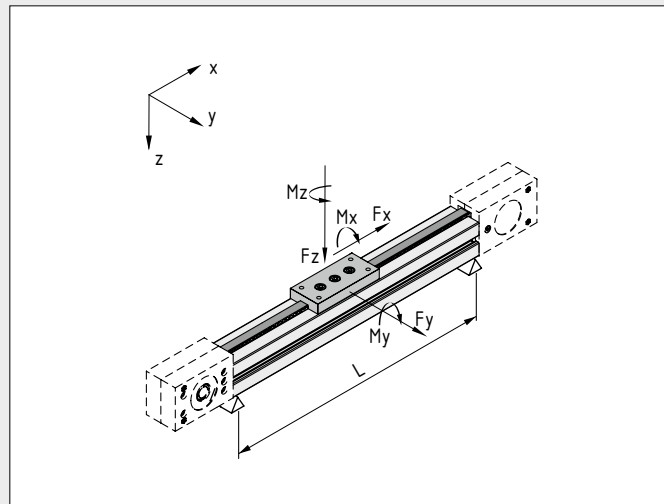
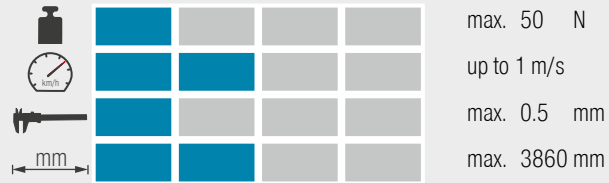

Linear Unit	Art. No.		Operating load $F_x$ max [N]	$F_y$ max [N]	$F_z$ max [N]	$M_x$ max [Nm]	$M_y$ max [Nm]	$M_z$ max [Nm]	Support width $L_{max}$ when $F_y$ max [mm]	Support width $L_{max}$ when $F_z$ max [mm]
Linear Unit GSF 8 40 R10	0.0.655.98	20	150	25	50	0.4	2	1.25	2400	2100

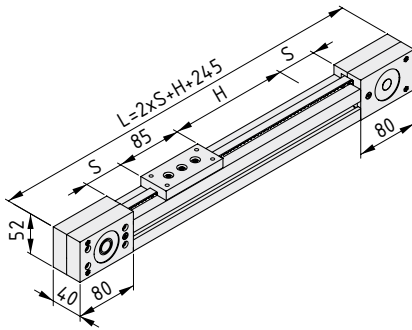
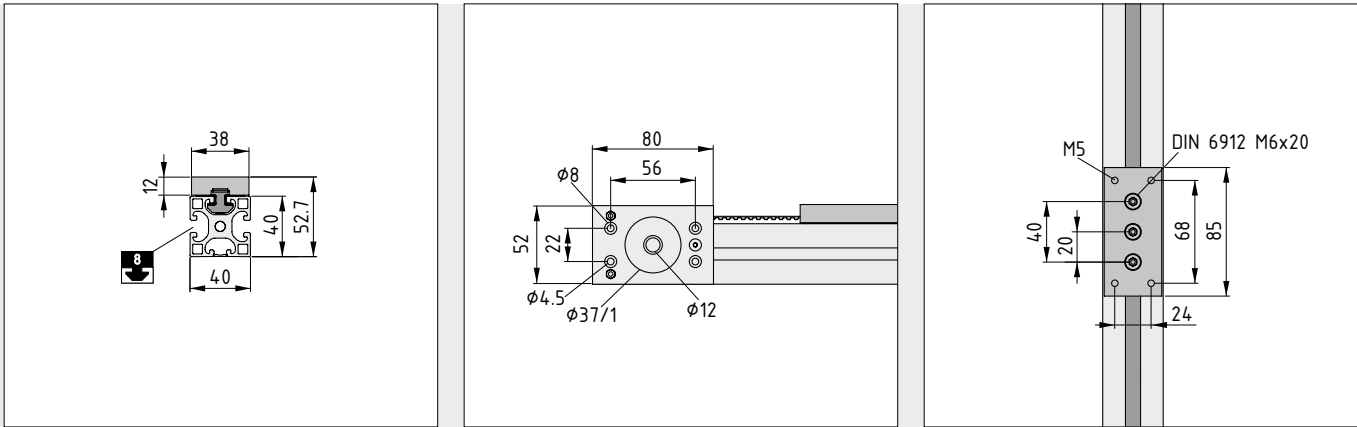

**Linear Unit GSF 8 40 R10**



Maximum stroke $H_{max}$	3860	mm
Safety clearance S	27.5	mm
Basic mass (when stroke length = 0 mm) $m_1$	1.1	kg
Mass per mm of stroke $m_2$	1.8	g/mm
Total mass $m =$	$m_1 + H * m_2$	
Repeatability	0.5	mm
Maximum acceleration	3	$m/s^2$
Maximum travelling speed	1	m/s
Feed constant	115	mm/r

1 pce.

0.0.655.98

**Compatible drive elements**

Plug-and-play Drive Set size	Universal Drive Set	Synchronising Set	Synchroniser Shaft Cover Set
40	✓	✓	✓



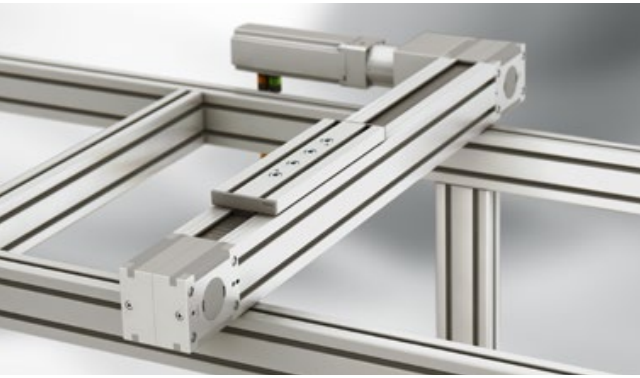

## Overview Linear Units KLE

- Roller elements run concealed inside the profile
- Especially compact design
- Available in the modular dimension of Lines 6 and 8



Everything in one housing. The roller elements of the compact item Linear Units KLE run inside the profile. With the exception of the carriage, none of the moving parts can be touched because the timing belt in the guide groove covers the moving elements. This enhances occupational health and safety and reduces soiling on the guides and roller elements.

Linear Units KLE are supplied ready to install in stroke lengths up to 5750 mm. They are available in the modular dimension of Lines 6 and 8 and with corresponding grooves on the outer sides. With an overall width of just 60 mm, including the carriage, Linear Unit KLE 6 is one of the slimmest Linear Units to feature a roller guide.

The special aluminium support profile ensures high load-carrying capacity and low-vibration operation. Thanks to their very smooth running and robust drive elements, Linear Units KLE are particularly suitable for high-speed positioning tasks.

The guide carriage runs on four roller elements and two hardened guiding shafts inside the profile. A Carriage Plate KLE or Transverse Carriage Plate KLE is used to connect applications. The tensioning device for the timing belt is integrated into the reverse unit.

Linear Units KLE have been tested for use in cleanrooms in line with ISO 14644-1 up to Class 6.



Carriage Plate KLE 141

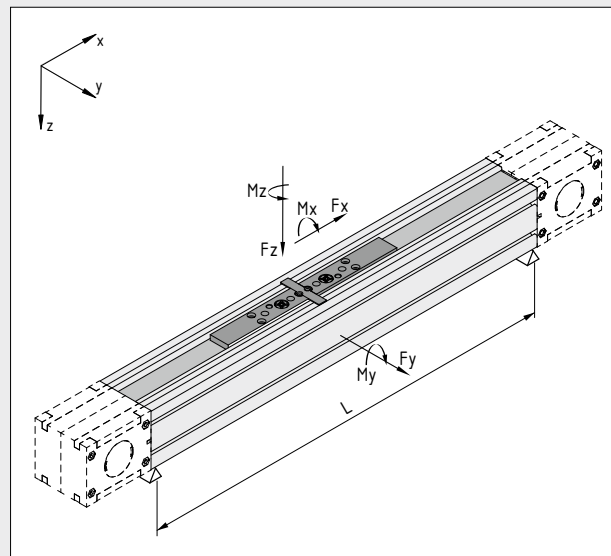

Linear Unit	Art. No.		Operating load $F_x$ max [N]	$F_y$ max [N]	$F_z$ max [N]	$M_x$ max [Nm]	$M_y$ max [Nm]	$M_z$ max [Nm]	Support width $L_{max}$ when $F_y$ max [mm]	Support width $L_{max}$ when $F_z$ max [mm]
Linear Unit KLE 6 60x60 LR	0.0.605.07	23	500	750	500	20	50	75	1500	1600
Linear Unit KLE 8 80x80 LR	0.0.605.02	24	1500	1500	1000	50	100	150	1900	2000



## Linear Unit KLE 6 60x60 LR

- Overall width of 60 mm, including carriage
- Excellent protection thanks to covered roller elements
- In modular dimension of Line 6

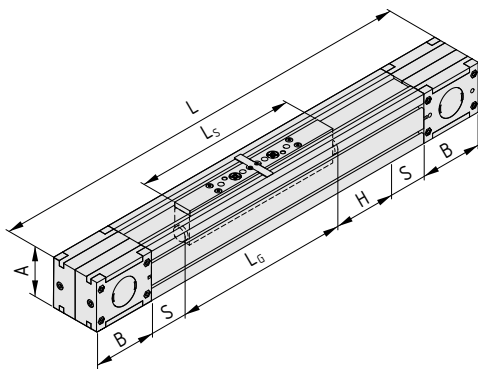
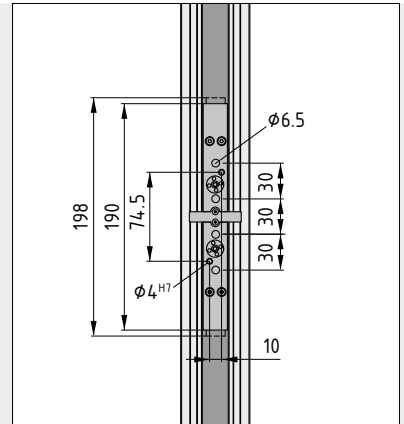
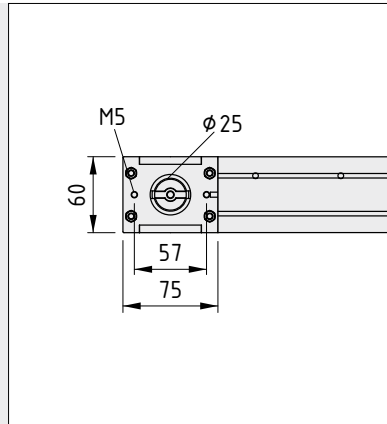
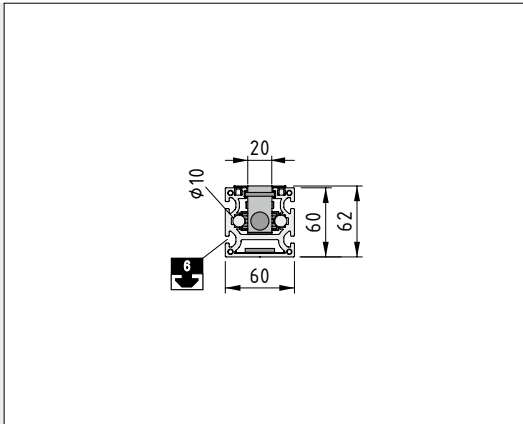

### Linear Unit KLE 6 60x60 LR



Overall length L	6150 mm
Visible carriage length $L_s$	190 mm
Carriage length $L_g$	198 mm
Housing height A	60 mm
Housing length B	75 mm
Maximum stroke $H_{max}$	5750 mm
Safety clearance S	26 mm
Basic mass (when stroke length = 0 mm) $m_1$	4.0 kg
Mass per mm of stroke $m_2$	4.8 g/mm
Total mass $m =$	$m_1 + H * m_2$
Repeatability	0.1 mm
Maximum acceleration	10 m/s <sup>2</sup>
Maximum travelling speed	10 m/s
Feed constant	155 mm/r

1 pce.

0.0.605.07

### Compatible drive elements

Plug-and-play Drive Set sizes	Universal Drive Set	Synchronising Set	Synchroniser Shaft Cover Set
60, 80	✓	✓	✓



## Linear Unit KLE 8 80x80 LR

- Excellent protection thanks to covered roller elements
- Strong and low-vibration
- In modular dimension of Line 8

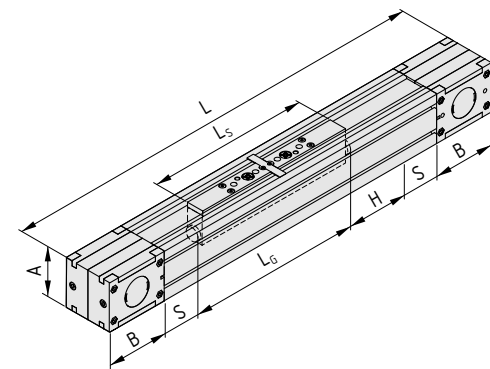
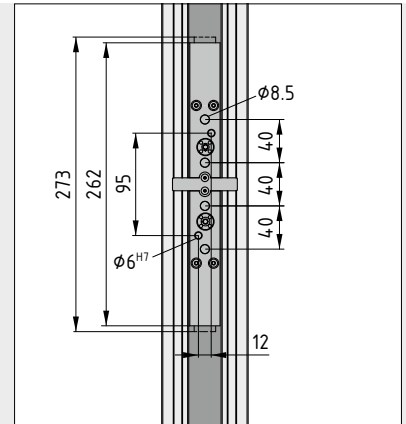
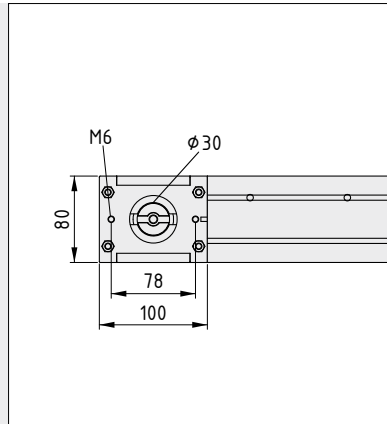
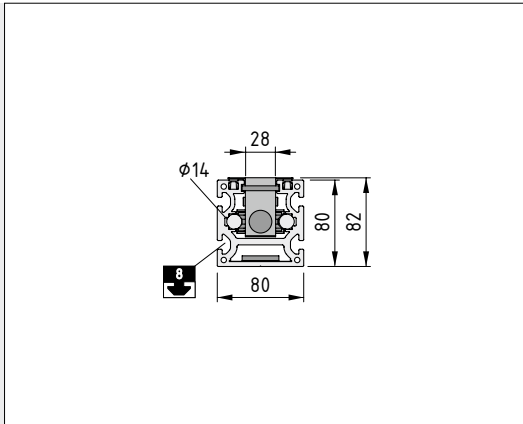

### Linear Unit KLE 8 80x80 LR



Overall length L	6200	mm
Visible carriage length $L_s$	262	mm
Carriage length $L_G$	273	mm
Housing height A	80	mm
Housing length B	100	mm
Maximum stroke $H_{max}$	5600	mm
Safety clearance S	63.5	mm
Basic mass (when stroke length = 0 mm) $m_1$	9.8	kg
Mass per mm of stroke $m_2$	8.7	g/mm
Total mass $m =$	$m_1 + H * m_2$	
Repeatability	0.1	mm
Maximum acceleration	10	$m/s^2$
Maximum travelling speed	10	m/s
Feed constant	210	mm/r

1 pce.

0.0.605.02

### Compatible drive elements

Plug-and-play Drive Set sizes	Universal Drive Set	Synchronising Set	Synchroniser Shaft Cover Set
60, 80	✓	✓	✓

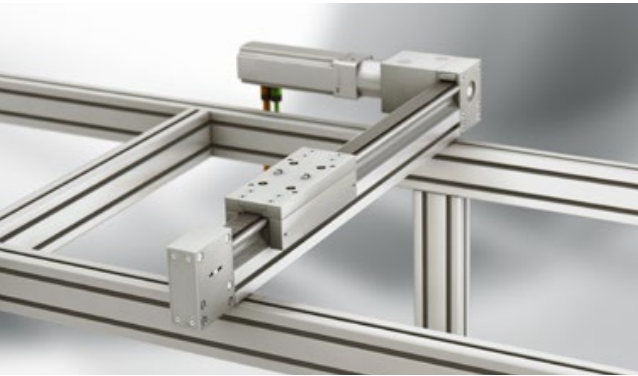

## Overview Linear Units KRF

- Extremely torsion-resistant profile
- Criss-crossed roller guide for optimum force transfer



Thanks to its criss-crossed roller guide and high-strength steel tracks, Linear Unit KRF is ideal for demanding applications. Two Linear Units KRF can work in parallel via a synchronous drive, with Linear Unit KRF 8 80x40 ZR, synchronous drive responsible for guidance. As the shaft on the drive side passes straight through, a synchroniser shaft can be connected to it. Synchronising Set KRF 8 80 ZR (0.0.648.58) is used to make this connection.

		max. 2500 N
		up to 10 m/s
		max. 0.1 mm
		max. 5760 mm

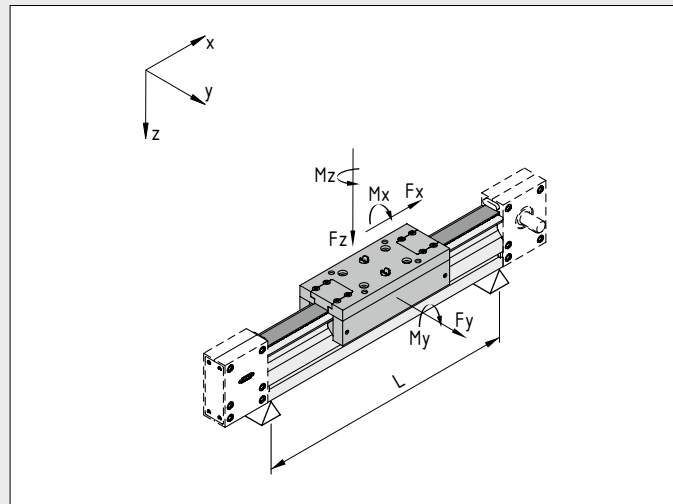

Linear Unit	Art. No.		Operating load $F_x$ max [N]	$F_y$ max [N]	$F_z$ max [N]	$M_x$ max [Nm]	$M_y$ max [Nm]	$M_z$ max [Nm]	Support width $L_{max}$ when $F_y$ max [mm]	Support width $L_{max}$ when $F_z$ max [mm]
Linear Unit KRF 8 80x40 ZR, left-hand input shaft	0.0.641.21	26	1000	2500	2500	50	140	140	500	1100
Linear Unit KRF 8 80x40 ZR, right-hand input shaft	0.0.648.66	26	1000	2500	2500	50	140	140	500	1100
Linear Unit KRF 8 80x40 ZR, synchronous drive	0.0.648.69	27	1000	2500	2500	50	140	140	500	1100

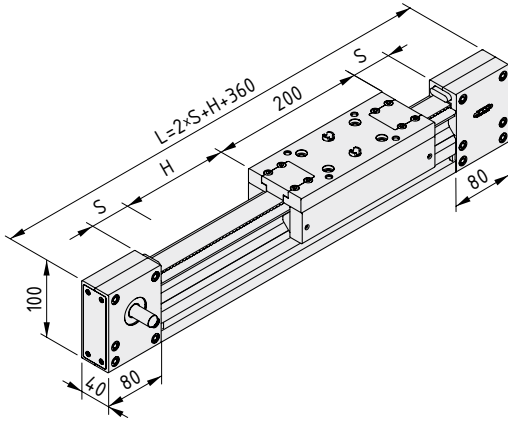
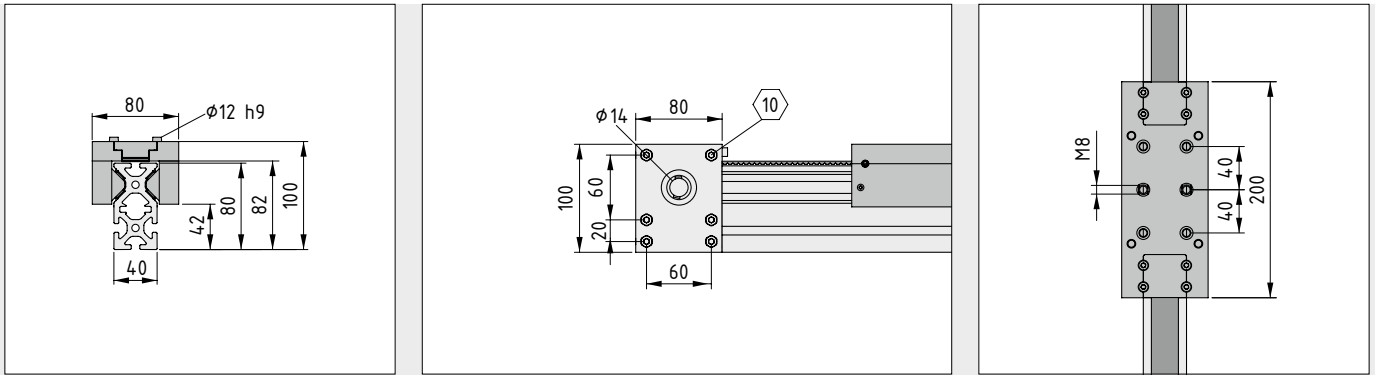

**Linear Unit KRF 8 80x40 ZR, right-hand input shaft**



Maximum stroke $H_{max}$	5760 mm
Safety clearance S	20 mm
Basic mass (when stroke length = 0 mm) $m_1$	5.1 kg
Mass per mm of stroke $m_2$	4.6 g/mm
Total mass $m =$	$m_1 + H * m_2$
Repeatability	0.1 mm
Maximum acceleration	10 $m/s^2$
Maximum travelling speed	10 m/s
Feed constant	145 mm/r

1 pce.

0.0.648.66

**Compatible drive elements**

Plug-and-play Drive Set sizes	Universal Drive Set	Synchronising Set	Synchroniser Shaft Cover Set
60, 80	✓	✓	✓

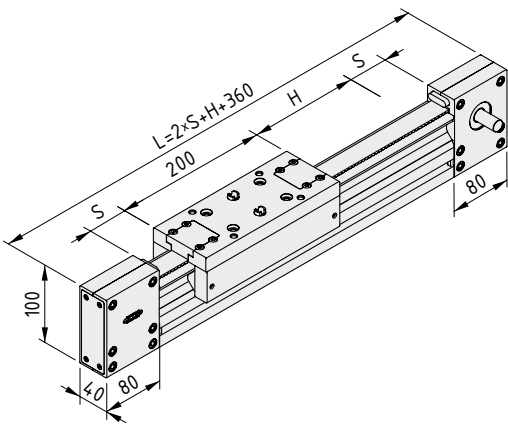

**Linear Unit KRF 8 80x40 ZR, left-hand input shaft**



Maximum stroke $H_{max}$	5760 mm
Safety clearance S	20 mm
Basic mass (when stroke length = 0 mm) $m_1$	5.1 kg
Mass per mm of stroke $m_2$	4.6 g/mm
Total mass $m =$	$m_1 + H * m_2$
Repeatability	0.1 mm
Maximum acceleration	10 $m/s^2$
Maximum travelling speed	10 m/s
Feed constant	145 mm/r

1 pce.

0.0.641.21

**Compatible drive elements**

Plug-and-play Drive Set sizes	Universal Drive Set	Synchronising Set	Synchroniser Shaft Cover Set
60, 80	✓	✓	✓



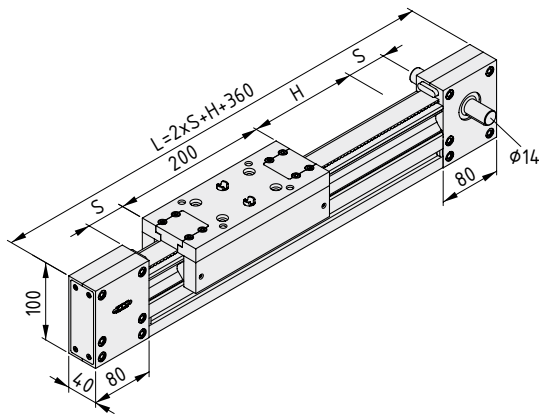

**Linear Unit KRF 8 80x40 ZR, synchronous drive**



Maximum stroke $H_{max}$	5760	mm
Safety clearance S	20	mm
Basic mass (when stroke length = 0 mm) $m_1$	5.0	kg
Mass per mm of stroke $m_2$	4.6	g/mm
Total mass $m =$	$m_1 + H * m_2$	
Repeatability	0.1	mm
Maximum acceleration	10	$m/s^2$
Maximum travelling speed	10	m/s
Feed constant	145	mm/r

1 pce.

0.0.648.69

**Compatible drive elements**

Plug-and-play Drive Set sizes	Universal Drive Set	Synchronising Set	Synchroniser Shaft Cover Set
60, 80	✓	✓	✓



## Linear Unit LRE 5 D6 60x20 ZU 40 R10

- Speedy, compact and versatile
- Extremely space-saving



The compact Linear Unit with exceptional performance. Thanks to stable roller elements and a fast timing-belt drive, Linear Unit LRE 5 D6 60x20 ZU 40 R10 is ideal for applications with limited installation space where short cycle times are important. Able to carry a payload of up to 32 kg, it can move heavier loads than a slide guide. The application is fastened to the streamlined slide via the system grooves on the carriage plate.

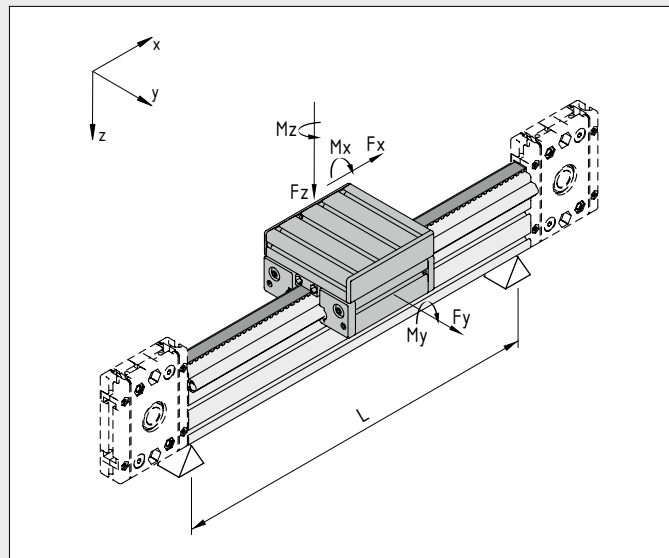

Linear Unit	Art. No.		Operating load Fx max [N]	Fy max [N]	Fz max [N]	Mx max [Nm]	My max [Nm]	Mz max [Nm]	Support width Lmax when Fy max [mm]	Support width Lmax when Fz max [mm]
Linear Unit LRE 5 D6 60x20 ZU 40 R10	0.0.666.89	28	150	400	320	4	6	8	400	1200

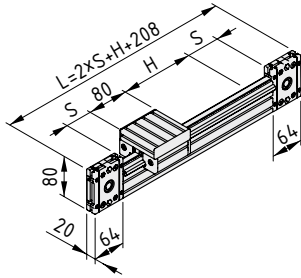
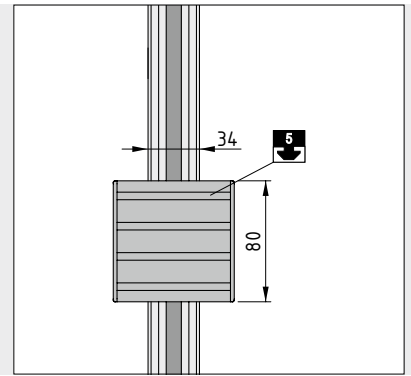
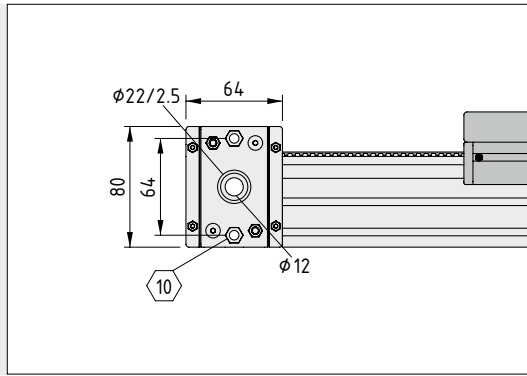
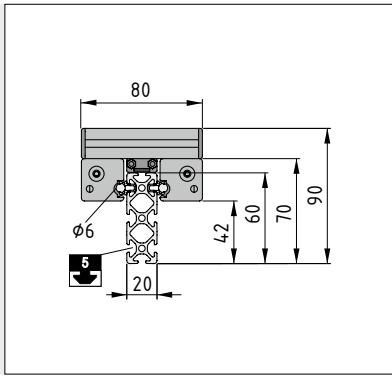

**Linear Unit LRE 5 D6 60x20 ZU 40 R10**



Maximum stroke $H_{max}$	2828	mm
Safety clearance S	46	mm
Basic mass (when stroke length = 0 mm) $m_1$	1.2	kg
Mass per mm of stroke $m_2$	1.9	g/mm
Total mass $m =$	$m_1 + H * m_2$	
Repeatability	0.15	mm
Maximum acceleration	10	$m/s^2$
Maximum travelling speed	5	m/s
Feed constant	140	mm/r

1 pce.

0.0.666.89

**Compatible drive elements**

Plug-and-play Drive Set size	Universal Drive Set	Synchronising Set	Synchroniser Shaft Cover Set
40	✓	✓	✗

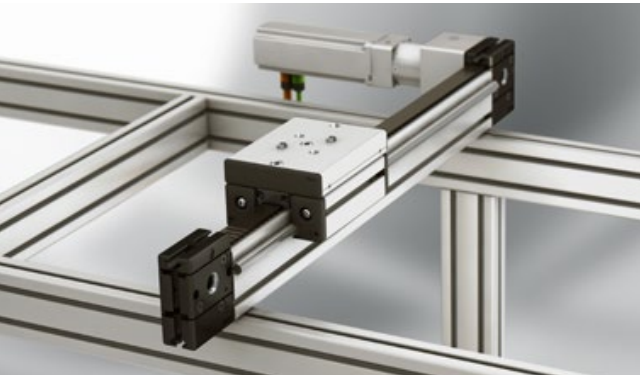

## Overview Linear Units LRE 8 D10

- Fast, strong and versatile
- Applications on the carriage can be easily switched
- Special lengths on request



Fast speed, streamlined dimensions and high payload – all are features of Linear Units LRE 8 D10. The carriage measures just 120 mm wide and is guided securely along steel shafts by roller elements.

The carriage has a flat surface for accommodating application-specific mounting holes.

The ingenious positioning collars ensure that the chosen application can be mounted on the carriage with exceptional precision. This reduces setup times and makes maintenance work easier. Various support profiles are available so that profile deflection can be minimised for high loads and support spans.

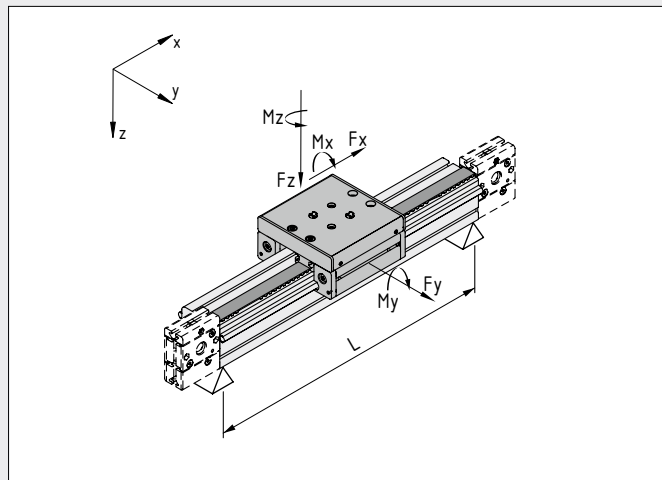

Linear Unit	Art. No.		Operating load $F_x$ max [N]	$F_y$ max [N]	$F_z$ max [N]	$M_x$ max [Nm]	$M_y$ max [Nm]	$M_z$ max [Nm]	Support width $L_{max}$ when $F_y$ max [mm]	Support width $L_{max}$ when $F_z$ max [mm]
Linear Unit LRE 8 D10 80x40 ZU 40 R25	0.0.662.70	31	870	1300	880	22	35	52	800	1900
Linear Unit LRE 8 D10 80x80 ZU 40 R25	0.0.663.32	32	870	1300	880	39	35	52	2100	2500



## Linear Unit LRE 8 D10 80x40 ZU 40 R25

- Maximum support span of 1900 mm when  $F_{z,max}$
- $M_{x,max}$  22 Nm

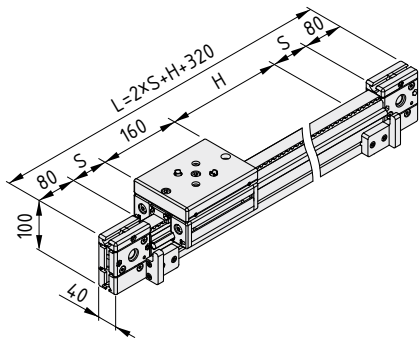
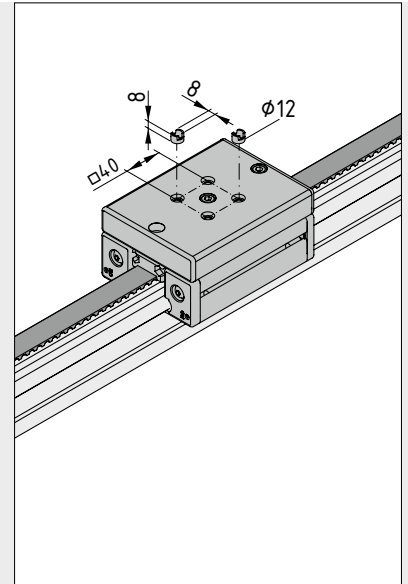
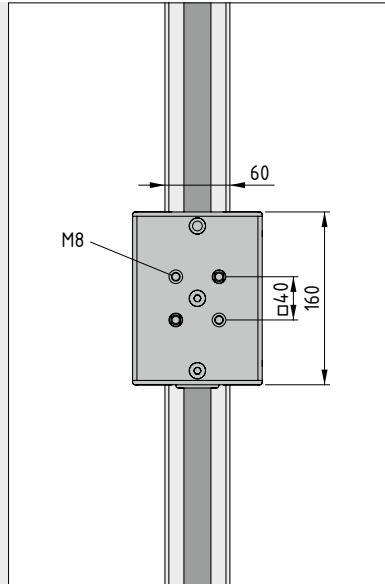
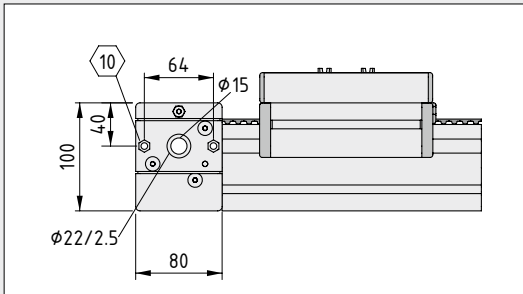
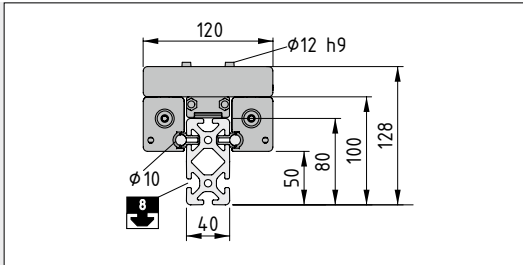

### Linear Unit LRE 8 D10 80x40 ZU 40 R25



Maximum stroke $H_{max}$	5760	mm
Safety clearance S	40	mm
Basic mass (when stroke length = 0 mm) $m_1$	6.7	kg
Mass per mm of stroke $m_2$	6.4	g/mm
Total mass $m =$	$m_1 + H * m_2$	
Repeatability	0.15	mm
Maximum acceleration	10	$m/s^2$
Maximum travelling speed	10	m/s
Feed constant	150	mm/r

1 pce.

0.0.662.70

### Compatible drive elements

Plug-and-play Drive Set size	Universal Drive Set	Synchronising Set	Synchroniser Shaft Cover Set
60	✓	✓	✗





### Linear Unit LRE 8 D10 80x80 ZU 40 R25

- Maximum support span 2500 mm when  $F_{z\max}$
- $M_{x\max}$  39 Nm

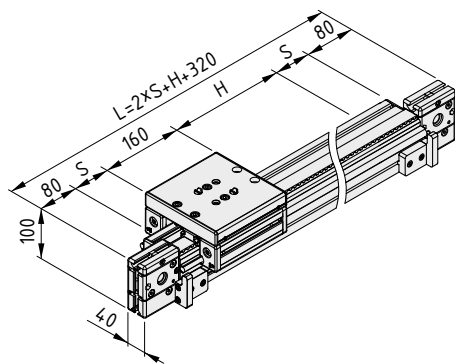
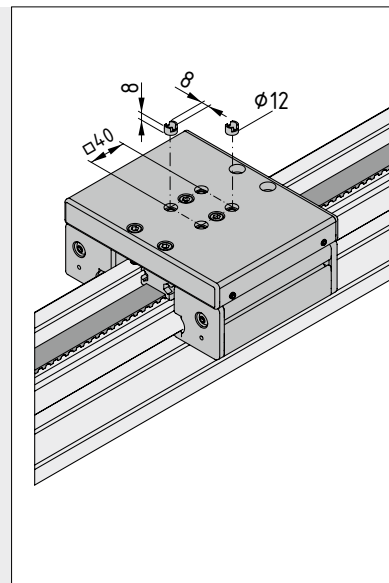
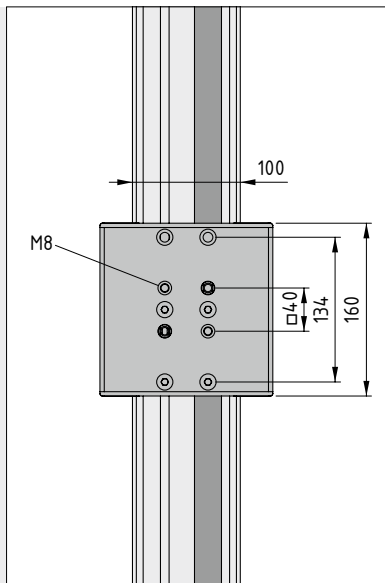
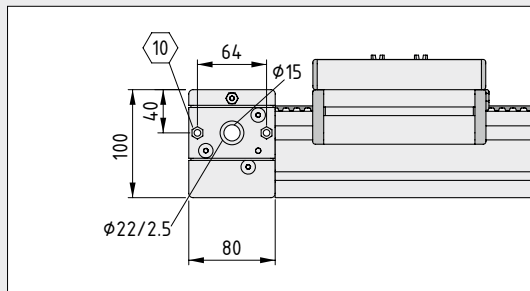
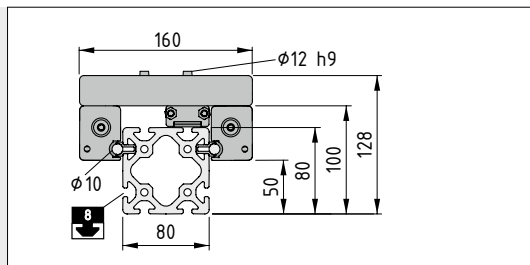

#### Linear Unit LRE 8 D10 80x80 ZU 40 R25



Maximum stroke $H_{\max}$	5760	mm
Safety clearance S	40	mm
Basic mass (when stroke length = 0 mm) $m_1$	7.8	kg
Mass per mm of stroke $m_2$	9.1	g/mm
Total mass $m =$	$m_1 + H * m_2$	
Repeatability	0.15	mm
Maximum acceleration	10	$m/s^2$
Maximum travelling speed	10	m/s
Feed constant	150	mm/r

1 pce.

0.0.663.32

#### Compatible drive elements

Plug-and-play Drive Set size	Universal Drive Set	Synchronising Set	Synchroniser Shaft Cover Set
60	✓	✓	✗



## Overview Linear Units LRE 8 D14

- Fast, strong and universal
- The strong all-rounder
- Special lengths on request

The standard Linear Units with impressive performance potential. Linear Units LRE 8 D14 offer the widest range of support profiles and a robust design for a long service life. The maximum payload of up to 160 kg opens up a broad range of potential applications.

The carriage has a flat surface for accommodating application-specific mounting holes and the ingenious positioning collars ensure that the chosen application can be mounted with exceptional precision. As a result, changeover and maintenance operations can be completed in record time. Various support profiles are available so that profile deflection can be minimised for high loads and support spans.

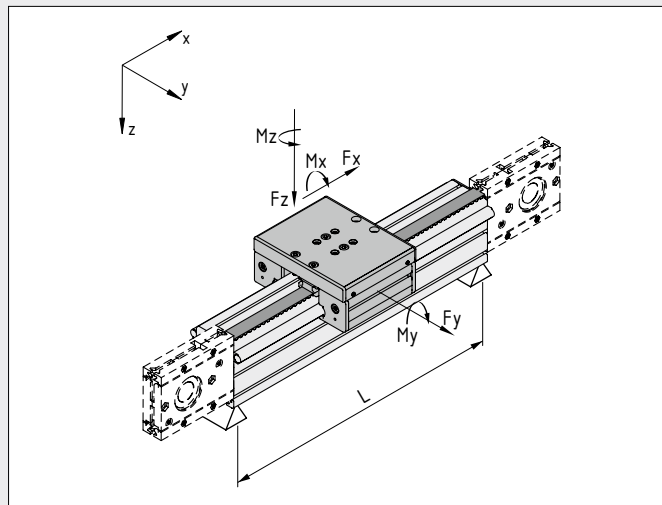

Linear Unit	Art. No.		Operating load $F_x$ max [N]	$F_y$ max [N]	$F_z$ max [N]	$M_x$ max [Nm]	$M_y$ max [Nm]	$M_z$ max [Nm]	Support width $L_{max}$ when $F_y$ max [mm]	Support width $L_{max}$ when $F_z$ max [mm]
Linear Unit LRE 8 D14 80x40 ZU 40 R25	0.0.662.91	34	870	2400	1600	40	64	96	600	1400
Linear Unit LRE 8 D14 80x40 ZU 80 R25	0.0.663.12	35	1200	2400	1600	40	64	96	600	1400
Linear Unit LRE 8 D14 80x80 ZU 40 R25	0.0.663.25	36	870	2400	1600	76	64	96	1500	1900
Linear Unit LRE 8 D14 80x80 ZU 80 R25	0.0.663.26	37	1200	2400	1600	76	64	96	1500	1900
Linear Unit LRE 8 D14 120x80 ZU 40 R25	0.0.663.34	38	870	2400	1600	76	64	96	1900	3200
Linear Unit LRE 8 D14 120x80 ZU 80 R25	0.0.663.35	39	1200	2400	1600	76	64	96	1900	3200



## Linear Unit LRE 8 D14 80x40 ZU 40 R25

- Maximum support span 1400 mm when  $F_{z\max}$
- Operating load 870 N

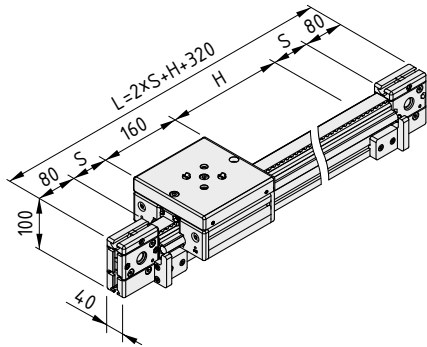
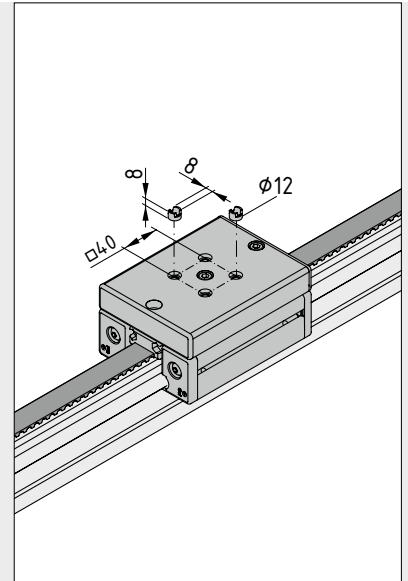
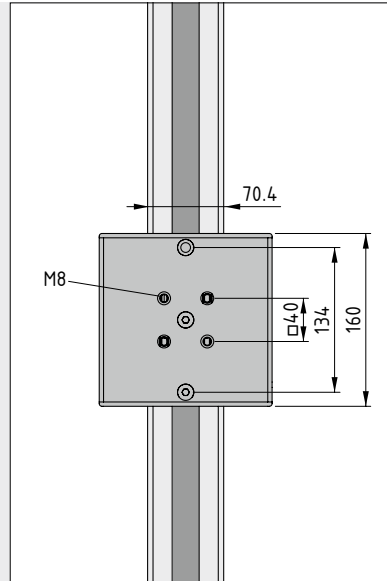
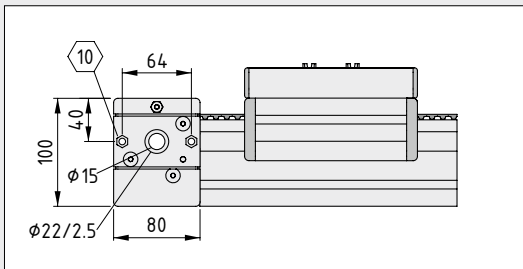
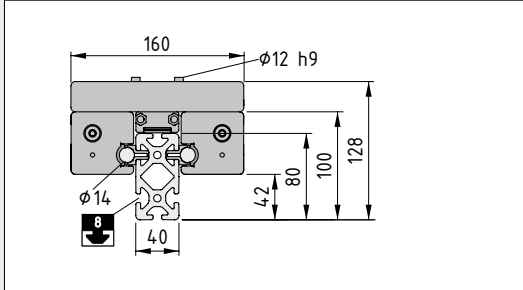

### Linear Unit LRE 8 D14 80x40 ZU 40 R25



Maximum stroke $H_{\max}$	5760	mm
Safety clearance S	40	mm
Basic mass (when stroke length = 0 mm) $m_1$	8.4	kg
Mass per mm of stroke $m_2$	7.8	g/mm
Total mass $m =$	$m_1 + H * m_2$	
Repeatability	0.15	mm
Maximum acceleration	10	$m/s^2$
Maximum travelling speed	10	m/s
Feed constant	150	mm/r

1 pce.

0.0.662.91

### Compatible drive elements

Plug-and-play Drive Set size	Universal Drive Set	Synchronising Set	Synchroniser Shaft Cover Set
60	✓	✓	✗



## Linear Unit LRE 8 D14 80x40 ZU 80 R25

- Maximum support span 1400 mm when  $F_{z \max}$
- Operating load 1200 N

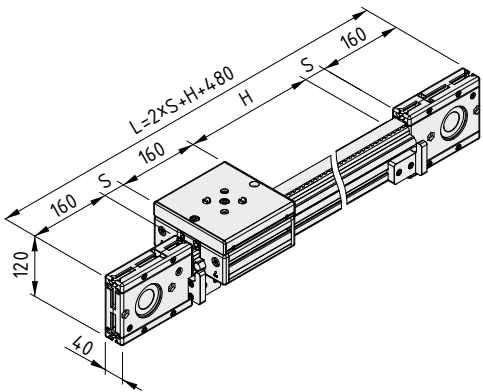
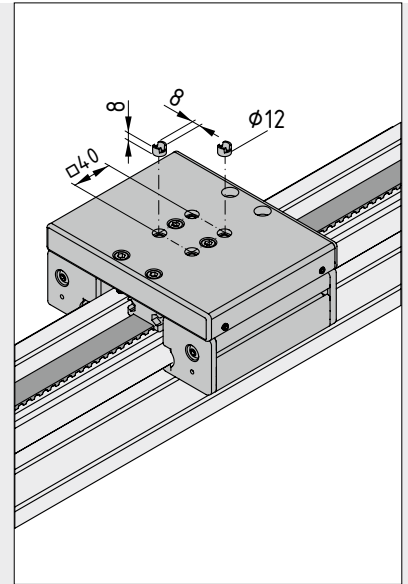
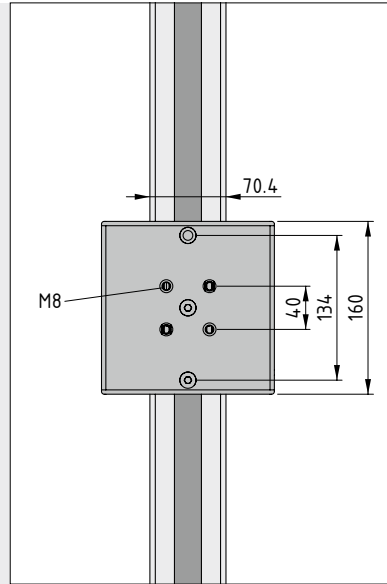
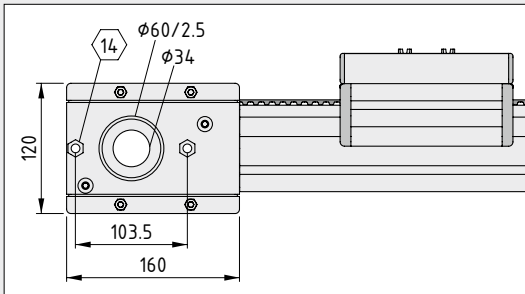
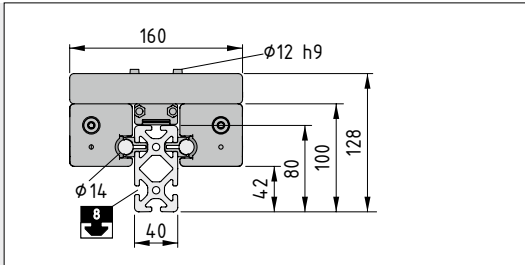

### Linear Unit LRE 8 D14 80x40 ZU 80 R25



Maximum stroke $H_{\max}$	5820	mm
Safety clearance $S$	10	mm
Basic mass (when stroke length = 0 mm) $m_1$	11.7	kg
Mass per mm of stroke $m_2$	7.8	g/mm
Total mass $m =$	$m_1 + H * m_2$	
Repeatability	0.15	mm
Maximum acceleration	10	$\text{m/s}^2$
Maximum travelling speed	10	m/s
Feed constant	280	mm/r

1 pce.

0.0.663.12

### Compatible drive elements

Plug-and-play Drive Set sizes	Universal Drive Set	Synchronising Set	Synchroniser Shaft Cover Set
60, 80	✓	✓	✗



### Linear Unit LRE 8 D14 80x80 ZU 40 R25

- Maximum support span 1900 mm when  $F_{z\max}$
- Operating load 870 N

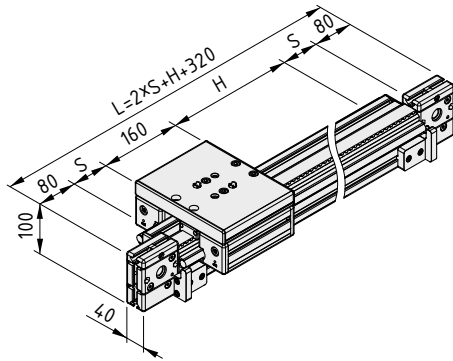
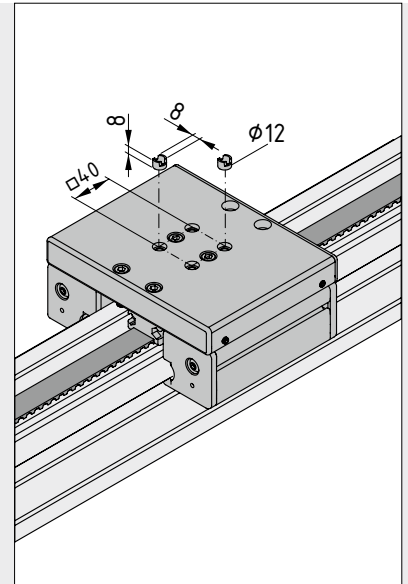
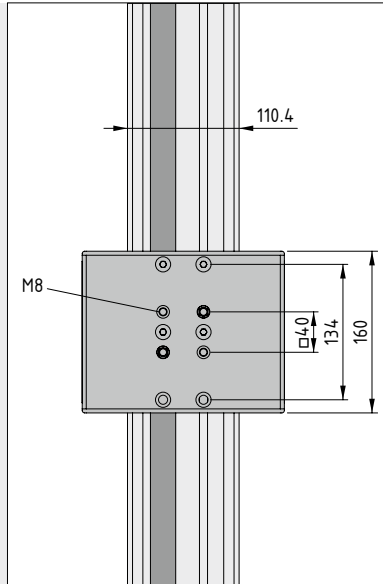
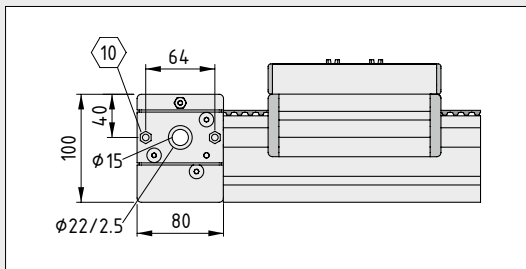
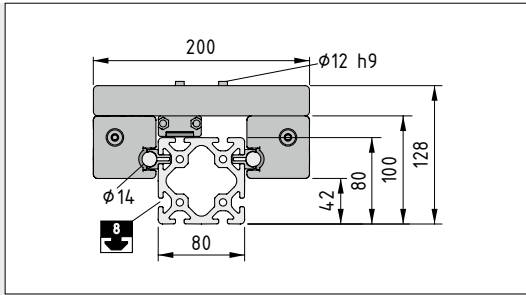

#### Linear Unit LRE 8 D14 80x80 ZU 40 R25



Maximum stroke $H_{\max}$	5760	mm
Safety clearance $S$	40	mm
Basic mass (when stroke length = 0 mm) $m_1$	9.4	kg
Mass per mm of stroke $m_2$	10.5	g/mm
Total mass $m =$	$m_1 + H * m_2$	
Repeatability	0.15	mm
Maximum acceleration	10	$m/s^2$
Maximum travelling speed	10	m/s
Feed constant	150	mm/r

1 pce.

0.0.663.25

#### Compatible drive elements

Plug-and-play Drive Set size	Universal Drive Set	Synchronising Set	Synchroniser Shaft Cover Set
60	✓	✓	✗



## Linear Unit LRE 8 D14 80x80 ZU 80 R25

- Maximum support span 1900 mm when  $F_{z \max}$
- Operating load 1200 N

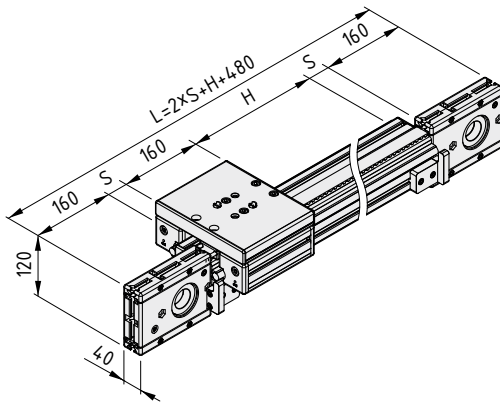
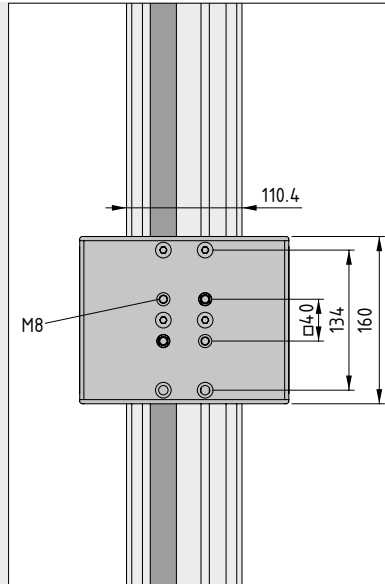
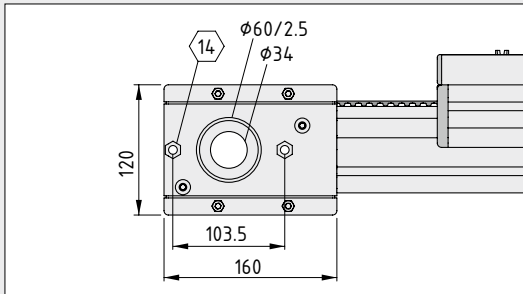
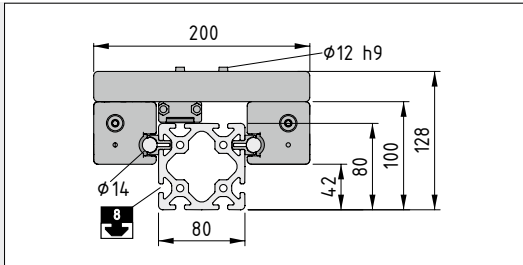

### Linear Unit LRE 8 D14 80x80 ZU 80 R25



Maximum stroke $H_{\max}$	5820	mm
Safety clearance S	10	mm
Basic mass (when stroke length = 0 mm) $m_1$	12.6	kg
Mass per mm of stroke $m_2$	10.5	g/mm
Total mass $m =$	$m_1 + H * m_2$	
Repeatability	0.15	mm
Maximum acceleration	10	$\text{m/s}^2$
Maximum travelling speed	10	m/s
Feed constant	280	mm/r

1 pce.

0.0.663.26

#### Compatible drive elements

Plug-and-play Drive Set sizes	Universal Drive Set	Synchronising Set	Synchroniser Shaft Cover Set
60, 80	✓	✓	✗



### Linear Unit LRE 8 D14 120x80 ZU 40 R25

- Maximum support span 3200 mm when  $F_{z\max}$
- Operating load 870 N

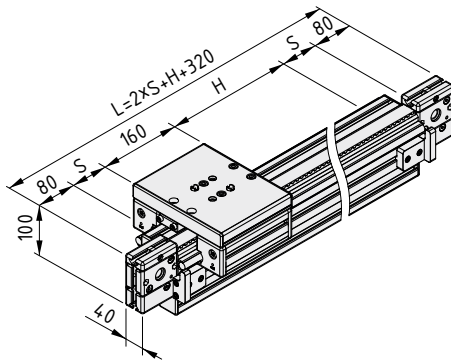
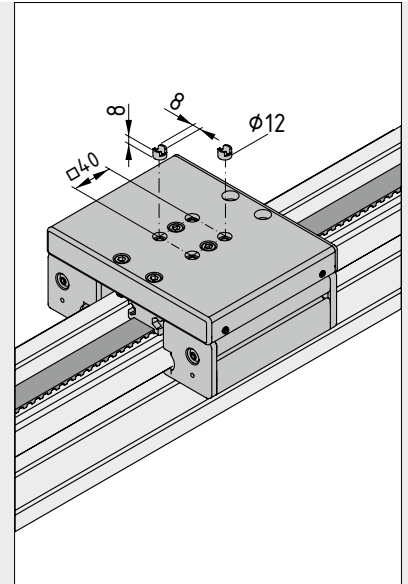
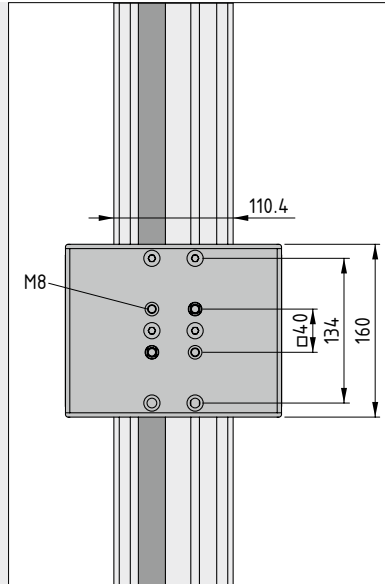
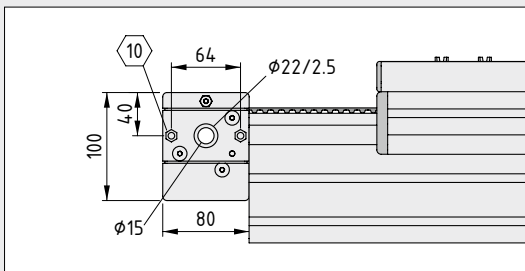
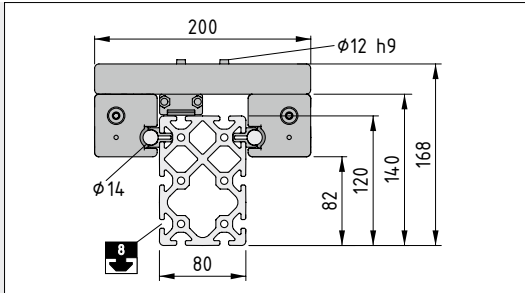

### Linear Unit LRE 8 D14 120x80 ZU 40 R25



Maximum stroke $H_{\max}$	5760	mm
Safety clearance S	40	mm
Basic mass (when stroke length = 0 mm) $m_1$	10.3	kg
Mass per mm of stroke $m_2$	14.2	g/mm
Total mass $m =$	$m_1 + H * m_2$	
Repeatability	0.15	mm
Maximum acceleration	10	$m/s^2$
Maximum travelling speed	10	m/s
Feed constant	150	mm/r

1 pce.

0.0.663.34

### Compatible drive elements

Plug-and-play Drive Set size	Universal Drive Set	Synchronising Set	Synchroniser Shaft Cover Set
60	✓	✓	✗





## Linear Unit LRE 8 D14 120x80 ZU 80 R25

- Maximum support span 3200 mm when  $F_{z\max}$
- Operating load 1200 N

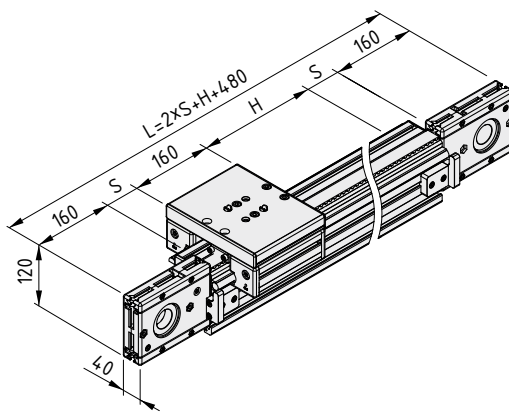
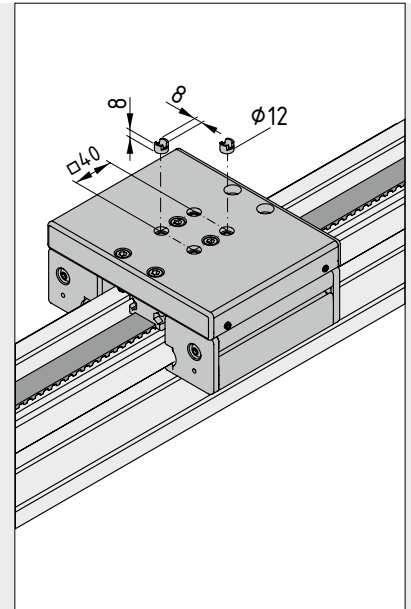
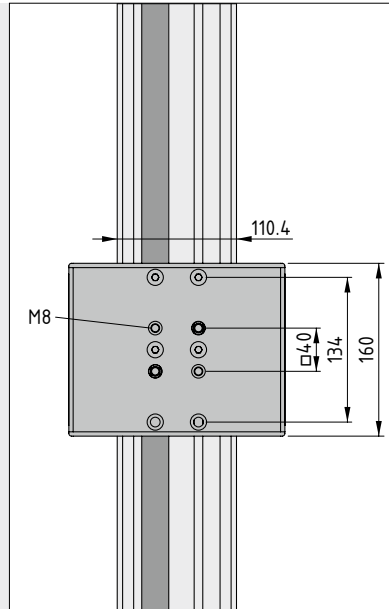
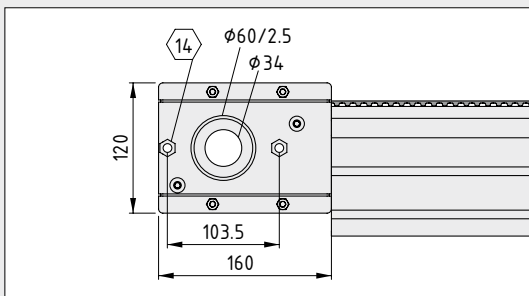
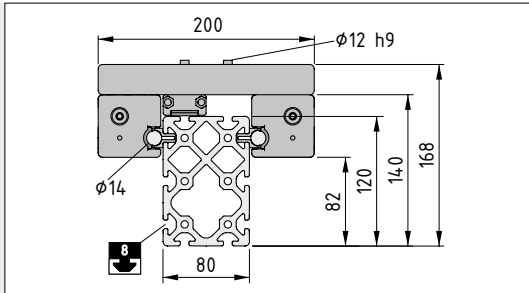

### Linear Unit LRE 8 D14 120x80 ZU 80 R25



Maximum stroke $H_{\max}$	5820	mm
Safety clearance S	10	mm
Basic mass (when stroke length = 0 mm) $m_1$	13.2	kg
Mass per mm of stroke $m_2$	14.2	g/mm
Total mass $m =$	$m_1 + H \cdot m_2$	
Repeatability	0.15	mm
Maximum acceleration	10	$m/s^2$
Maximum travelling speed	10	m/s
Feed constant	280	mm/r

1 pce.

0.0.663.35

### Compatible drive elements

Plug-and-play Drive Set sizes	Universal Drive Set	Synchronising Set	Synchroniser Shaft Cover Set
60, 80	✓	✓	✗



## Overview Linear Units LRE 8 D25

- For payloads up to 5200 N
- The Linear Units for heavy loads

The Linear Units for heavy-duty use. Linear Units LRE 8 D25 can transport payloads up to 5200 N. Solid roller elements, stable steel shafts and support profiles with a cross-section measuring up to 200 x 80 mm make it possible to transport these types of load. The roller guide and high-performance timing-belt drive create the ideal conditions for high-speed operation. A 50 mm-wide timing belt is also available for high operating forces generated by hard acceleration and deceleration. Various support profiles can be selected to minimise profile deflection in the case of high loads and large support spans. The application is fastened to the stable carriage via the system grooves on the carriage plate.

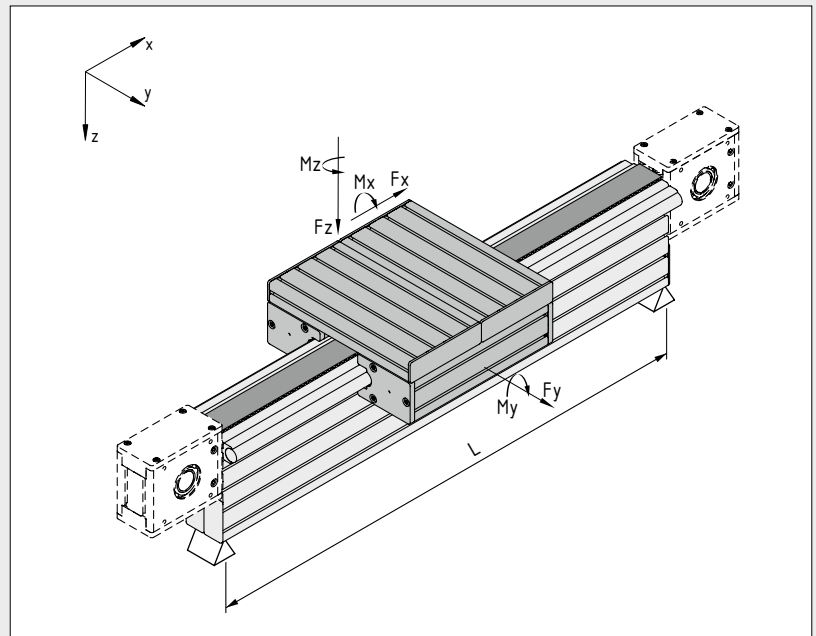

Linear Unit	Art. No.		Operating load $F_x$ max [N]	$F_y$ max [N]	$F_z$ max [N]	$M_x$ max [Nm]	$M_y$ max [Nm]	$M_z$ max [Nm]	Support width $L_{max}$ when $F_y$ max [mm]	Support width $L_{max}$ when $F_z$ max [mm]
Linear Unit LRE 8 D25 120x80 ZU 80 R25	0.0.663.36	41	1200	7600	5200	301	520	760	1000	1900
Linear Unit LRE 8 D25 120x80 ZU 80 R50	0.0.666.65	42	2100	7600	5200	301	520	760	1000	1900
Linear Unit LRE 8 D25 200x80 ZU 80 R25	0.0.666.53	43	1200	7600	5200	301	520	760	1300	3600
Linear Unit LRE 8 D25 200x80 ZU 80 R50	0.0.666.66	44	2100	7600	5200	301	520	760	1300	3600



## Linear Unit LRE 8 D25 120x80 ZU 80 R25

- Maximum support span 1900 mm when  $F_{z,max}$
- Operating load 1200 N

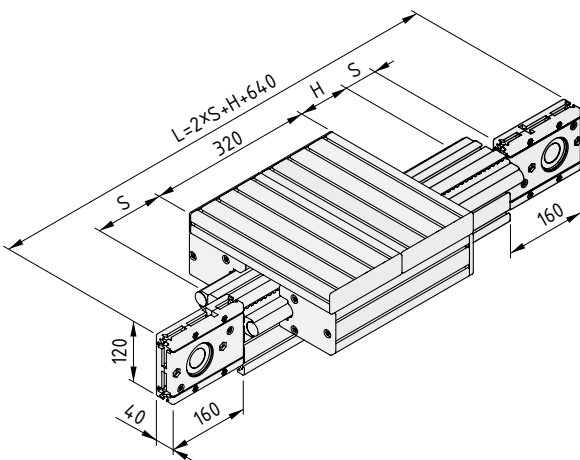
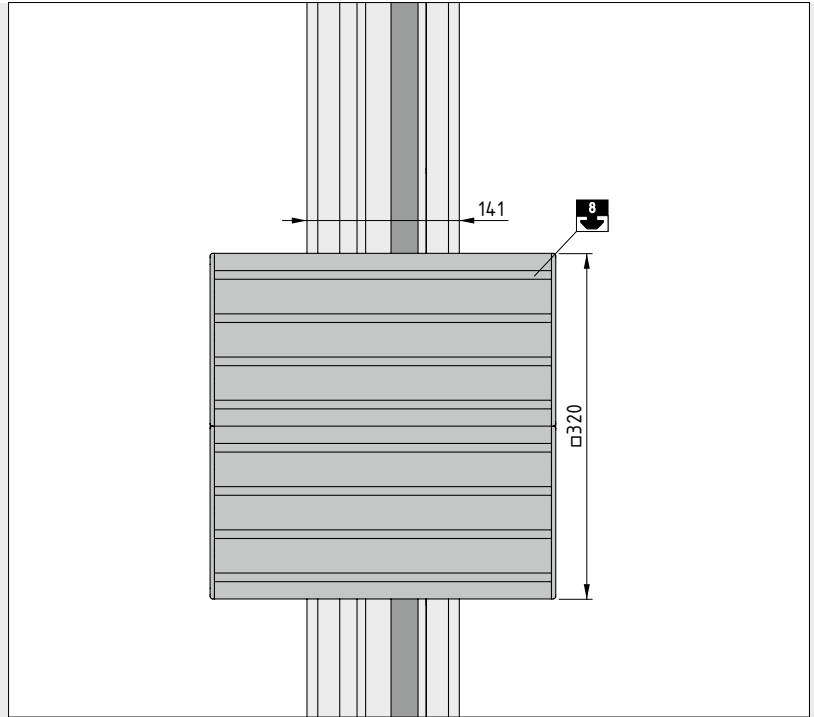
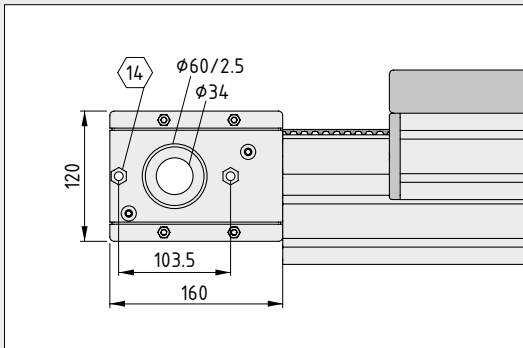
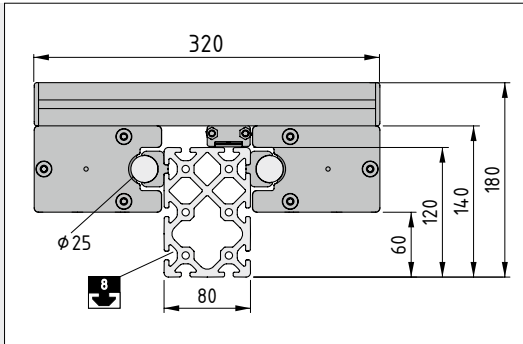

### Linear Unit LRE 8 D25 120x80 ZU 80 R25



Maximum stroke $H_{max}$	5620	mm
Safety clearance S	30	mm
Basic mass (when stroke length = 0 mm) $m_1$	31.1	kg
Mass per mm of stroke $m_2$	20.7	g/mm
Total mass $m =$	$m_1 + H * m_2$	
Repeatability	0.15	mm
Maximum acceleration	10	$m/s^2$
Maximum travelling speed	10	m/s
Feed constant	280	mm/r

1 pce.

0.0.663.36

### Compatible drive elements

Plug-and-play Drive Set sizes	Universal Drive Set	Synchronising Set	Synchroniser Shaft Cover Set
60, 80	✓	✓	✗



### Linear Unit LRE 8 D25 120x80 ZU 80 R50

- Maximum support span 1900 mm when  $F_{z,max}$
- Operating load 2100 N

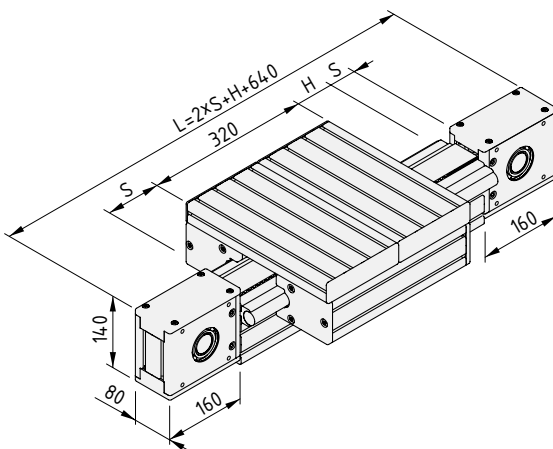
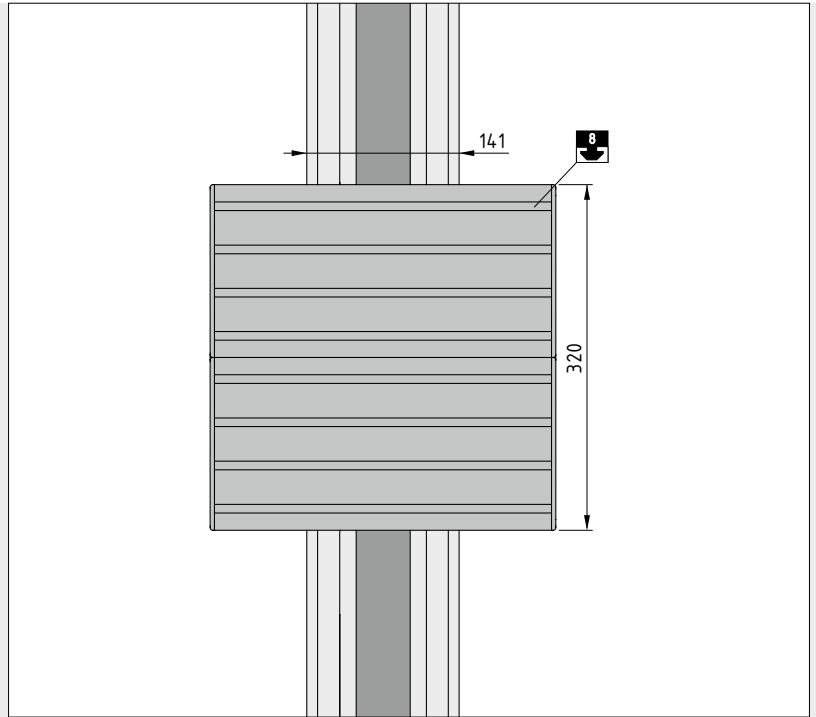
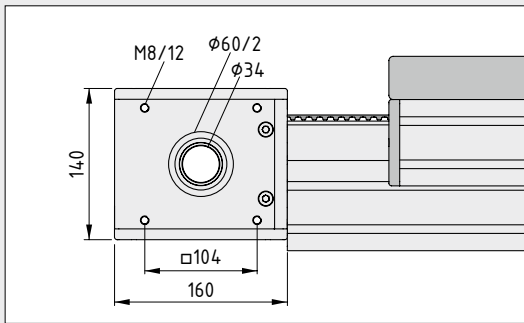
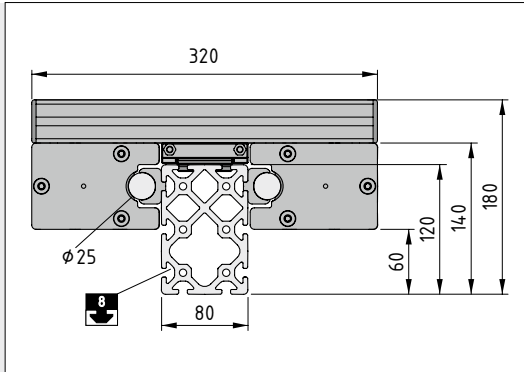

#### Linear Unit LRE 8 D25 120x80 ZU 80 R50



Maximum stroke $H_{max}$	5620	mm
Safety clearance S	30	mm
Basic mass (when stroke length = 0 mm) $m_1$	32.6	kg
Mass per mm of stroke $m_2$	20.9	g/mm
Total mass $m =$	$m_1 + H * m_2$	
Repeatability	0.15	mm
Maximum acceleration	10	$m/s^2$
Maximum travelling speed	10	m/s
Feed constant	280	mm/r

1 pce.

0.0.666.65

#### Compatible drive elements

Plug-and-play Drive Set size	Universal Drive Set	Synchronising Set	Synchroniser Shaft Cover Set
80	✓	✓	✗



## Linear Unit LRE 8 D25 200x80 ZU 80 R25

- Maximum support span 3600 mm when  $F_{z\max}$
- Operating load 1200 N

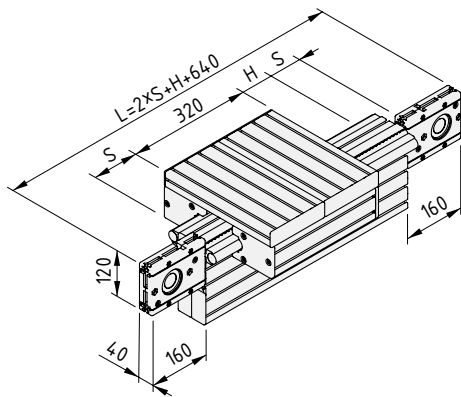
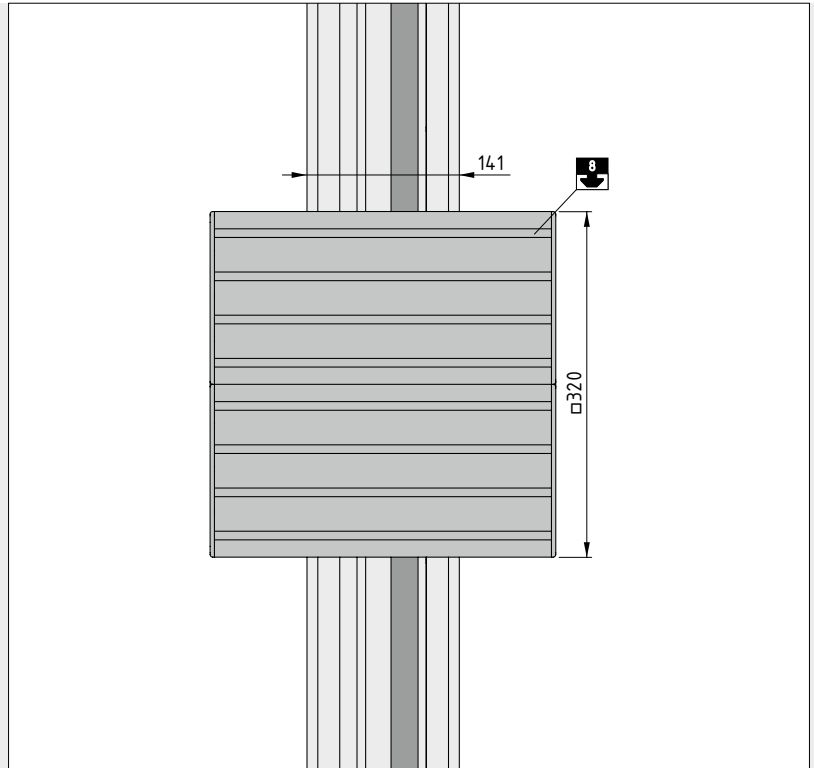
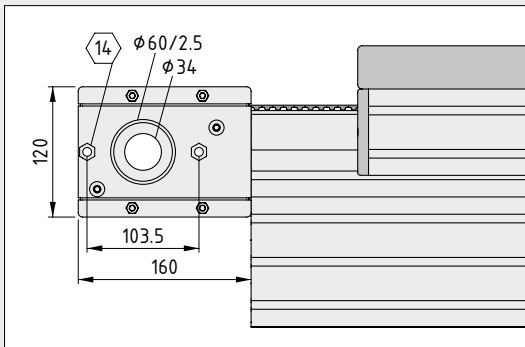
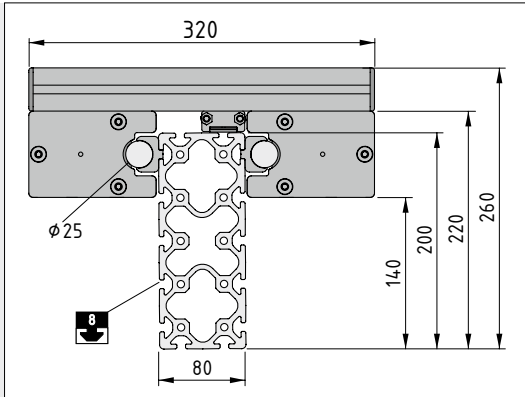

### Linear Unit LRE 8 D25 200x80 ZU 80 R25



Maximum stroke $H_{\max}$	5620	mm
Safety clearance S	30	mm
Basic mass (when stroke length = 0 mm) $m_1$	32.8	kg
Mass per mm of stroke $m_2$	25.0	g/mm
Total mass $m =$	$m_1 + H \cdot m_2$	
Repeatability	0.15	mm
Maximum acceleration	10	$m/s^2$
Maximum travelling speed	10	m/s
Feed constant	280	mm/r

1 pce.

0.0.666.53

#### Compatible drive elements

Plug-and-play Drive Set sizes	Universal Drive Set	Synchronising Set	Synchroniser Shaft Cover Set
60, 80	✓	✓	✗



## Linear Unit LRE 8 D25 200x80 ZU 80 R50

- Maximum support span 3600 mm when  $F_{z\max}$
- Operating load 2100 N

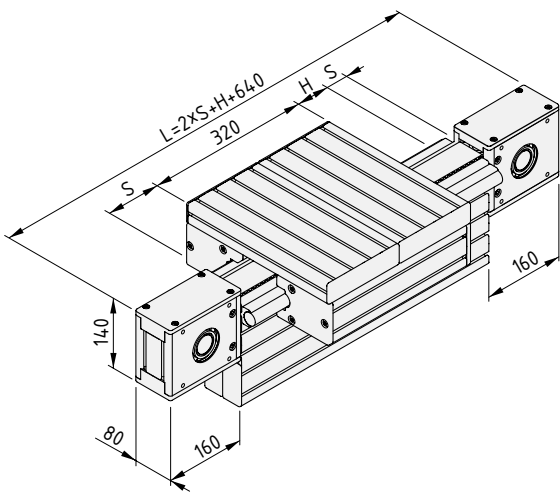
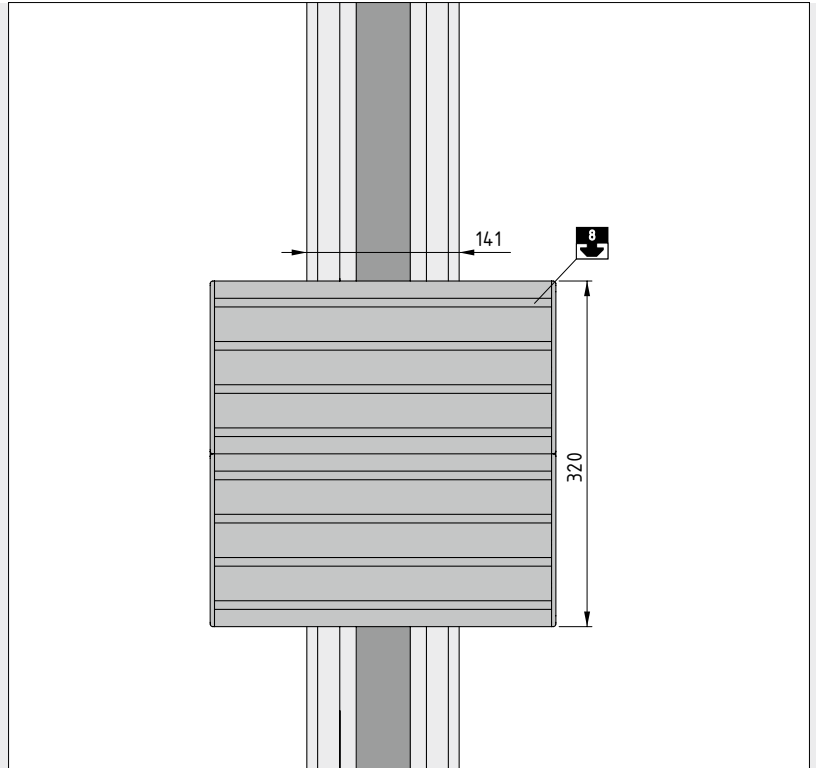
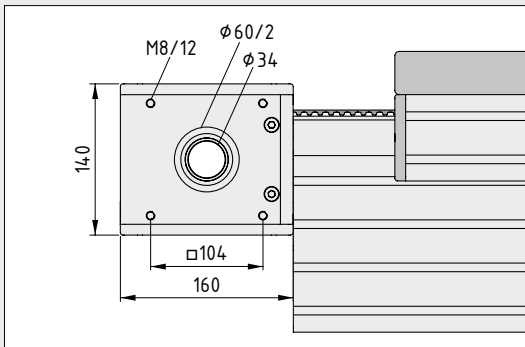
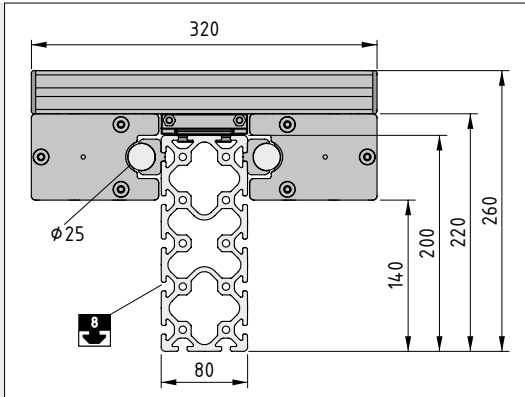

### Linear Unit LRE 8 D25 200x80 ZU 80 R50



Maximum stroke $H_{\max}$	5620	mm
Safety clearance S	30	mm
Basic mass (when stroke length = 0 mm) $m_1$	34.4	kg
Mass per mm of stroke $m_2$	25.3	g/mm
Total mass $m =$	$m_1 + H * m_2$	
Repeatability	0.15	mm
Maximum acceleration	10	$m/s^2$
Maximum travelling speed	10	m/s
Feed constant	280	mm/r

1 pce.

0.0.666.66

### Compatible drive elements

Plug-and-play Drive Set size	Universal Drive Set	Synchronising Set	Synchroniser Shaft Cover Set
80	✓	✓	✗



## Linear Units with a ball screw drive

The specialist for precision and drive force: A Ball Screw Unit is used when a great deal of power and precise positioning are required.

This is made possible by the drive principle: A Ball Screw Unit is based on a precision spindle. The speed and positioning accuracy of the system are largely determined by the lead on the thread. A non-turning drive nut that houses ball bearings is fitted to the spindle. These ball bearings circulate in the thread and ensure that the nut moves along a straight axis as the spindle turns. Because the ball bearings are very slightly larger than the track in which they run, they produce a pre-tensioning effect that eliminates play and supports load-carrying capacity. Using a spindle with a large lead boosts the travel speed that the Ball Screw Unit can achieve.

The length of the spindle limits its revolution speed. As a result, a spindle with a large lead is preferable for high driving rates. This design is less prone to uncontrolled carriage movement in vertical applications – due to the transmission ratio of the Ball Screw Unit, the drive only has to provide low braking torque.





## Linear Unit KGT 6 60 P20

- Compact design and long travel distance
- Smooth running thanks to spindle supports
- With robust, precise recirculating ball units



Linear Unit KGT 6 60 P20 combines a ball screw drive that has a stroke of up to 2600 mm with a strong carriage, and does so in the smallest of installation spaces.

The carriage runs on two recirculating ball units mounted on a profile rail. The minimal reversal play enables reliable positioning with a repeatability of 0.01 mm at an operating load of up to 1000 N.

In applications with a long travel distance, travelling spindle supports keep everything running smoothly and precisely. Radial stabilisers on the inside of the axis provide perfect support for the specially shaped spindle, regardless of the carriage position. Featuring a spindle lead of 20 mm, the system can reach a speed of up to 1 m/s, even at maximum stroke. Acceleration is up to 15 m/s<sup>2</sup>.

Thanks to its installation dimensions of just 60x60 mm and two Line 6 grooves on its side flanks, Linear Unit KGT 6 60 is very easy to integrate into constructions. An unbroken cover strip conceals the inner workings and therefore provides protection from soiling.

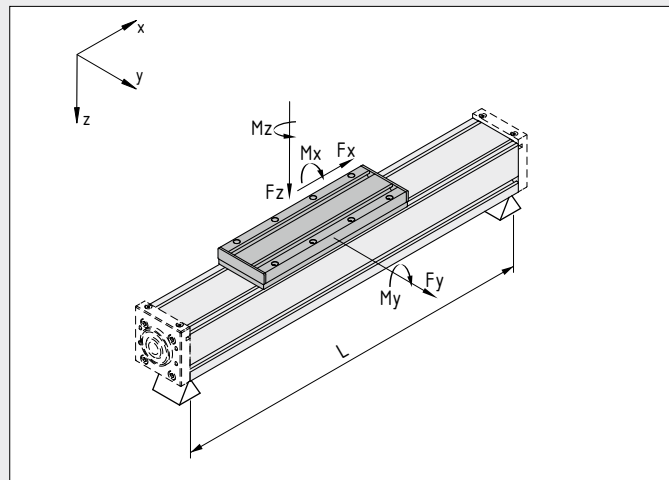

Linear Unit	Art. No.		Operating load $F_x$ max [N]	$F_y$ max [N]	$F_z$ max [N]	$M_x$ max [Nm]	$M_y$ max [Nm]	$M_z$ max [Nm]	Support width $L_{max}$ when $F_y$ max [mm]	Support width $L_{max}$ when $F_z$ max [mm]
Linear Unit KGT 6 60 P20	0.0.706.00	47	1000	2000	2000	15	120	120	850	650

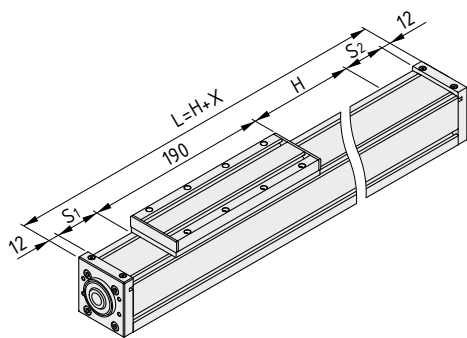

**Linear Unit KGT 6 60 P20**



Maximum stroke $H_{max}$	2600	mm
Mass per mm of stroke $m_2$	4.2	g/mm
Total mass $m =$	$m_1 + H * m_2$	
Repeatability	0.01	mm
Maximum acceleration	15	$m/s^2$
Maximum travelling speed	1	m/s
Feed constant	20	mm/r

1 pce. 0.0.706.00

The overall length (L) of the Linear Unit and the safety clearances at the sides ( $S_1/S_2$ ) are determined by the desired stroke length (H) (see drawing and table).

H [mm]	X [mm]	$S_1$ [mm]	$S_2$ [mm]	$m_1$ [kg]
0-1000	323	56	53	2,635
1001-1560	355	72	69	2,855
1561-2120	387	88	85	3,053
2121-2600	419	104	101	3,253

**Compatible drive elements**

Plug-and-play Drive Set sizes	Universal Drive Set	Synchronising Set	Synchroniser Shaft Cover Set
40, 60	✓	✗	✗



## Overview of Linear Units LRE 8 D10 80x80 KGT

- Compact carriage with D10 roller elements
- Payloads up to 880 N
- Two spindle leads available

Linear Units LRE 8 D10 80x80 KGT offer the excellent precision of a ball screw drive for applications with a payload of up to 880 N. The 160x160 mm carriage is guided by roller elements with a diameter of D10 that run on hardened steel shafts.

Two spindle leads are available. The 5 mm lead translates a low drive torque into a very high operating force. The spindle lead of 20 mm enables a maximum speed of up to 1 m/s combined with a high operating load.

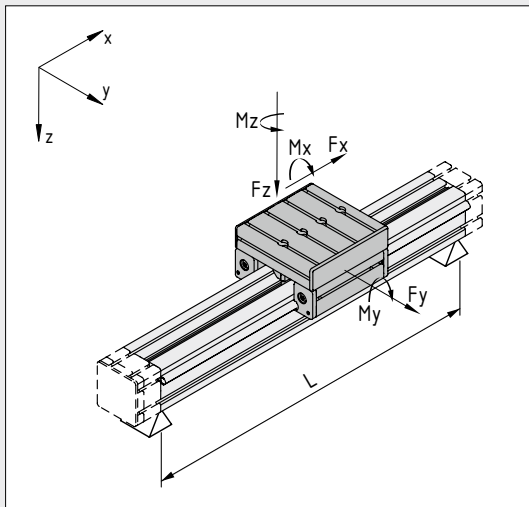

Linear Unit	Art. No.		Operating load $F_x$ max [N]	$F_y$ max [N]	$F_z$ max [N]	$M_x$ max [Nm]	$M_y$ max [Nm]	$M_z$ max [Nm]	Support width $L_{max}$ when $F_z$ max [mm]	Support width $L_{max}$ when $F_y$ max [mm]
Linear Unit LRE 8 D10 80x80 KGT 20x5	0.0.668.12	49	2000	1300	880	39	35	52	2500	2200
Linear Unit LRE 8 D10 80x80 KGT 20x20	0.0.668.10	50	2000	1300	880	39	35	52	2500	2200

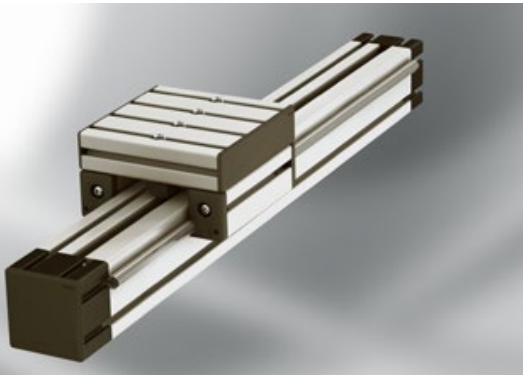

## Linear Unit LRE 8 D10 80x80 KGT 20x5

- Precise with strong drive
- High rigidity

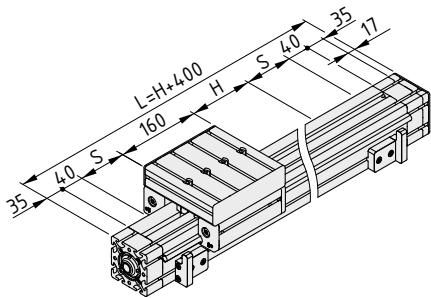
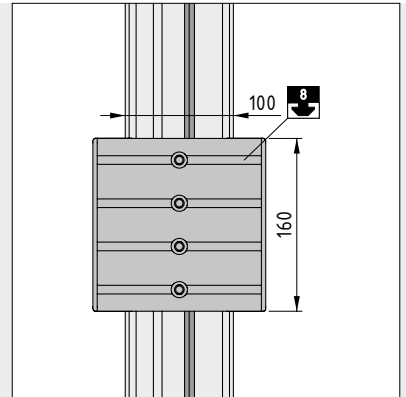
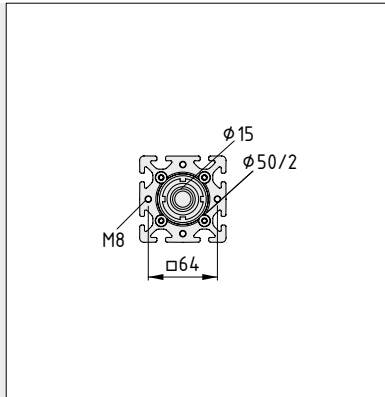
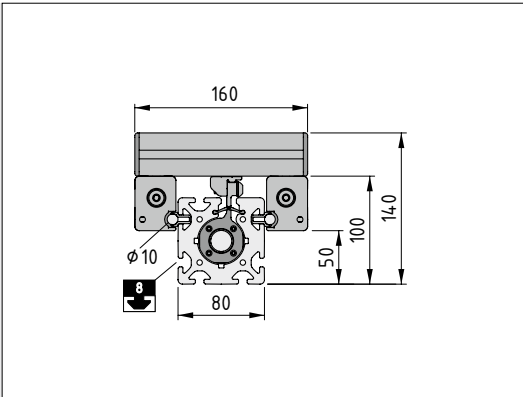

### Linear Unit LRE 8 D10 80x80 KGT 20x5



Maximum stroke $H_{max}$	2687	mm
Safety clearance S	76.5	mm
Basic mass (when stroke length = 0 mm) $m_1$	8.3	kg
Mass per mm of stroke $m_2$	12.8	g/mm
Total mass $m =$	$m_1 + H * m_2$	
Repeatability	0.05	mm
Maximum acceleration	5	$m/s^2$
Maximum travelling speed	0.25	m/s
Feed constant	5	mm/r

1 pce.

0.0.668.12

### Compatible drive elements

Plug-and-play Drive Set sizes	Universal Drive Set	Synchronising Set	Synchroniser Shaft Cover Set
60, 80	✓	✗	✗



### Linear Unit LRE 8 D10 80x80 KGT 20x20

- Extremely precise positioning
- Highly rigid drive

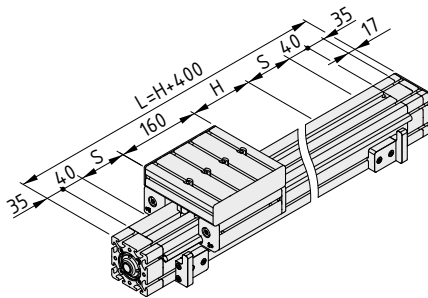
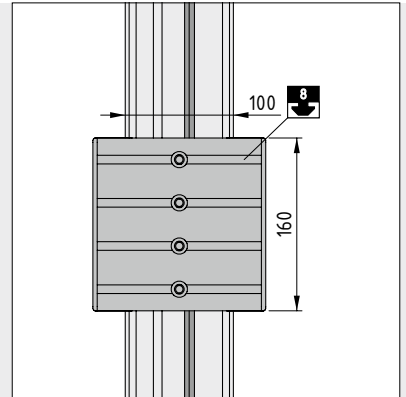
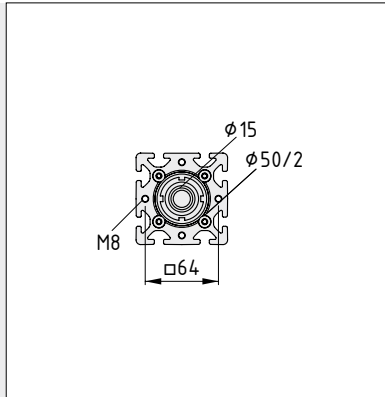
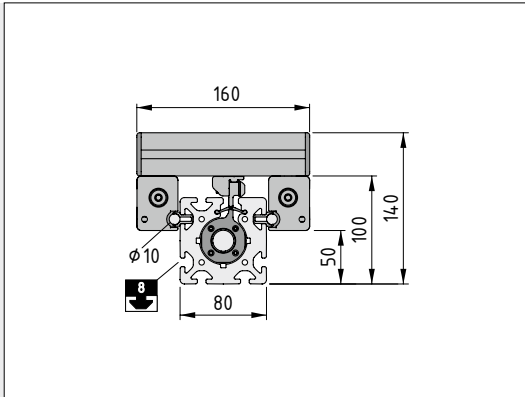

### Linear Unit LRE 8 D10 80x80 KGT 20x20



Maximum stroke $H_{max}$	2687	mm
Safety clearance S	76.5	mm
Basic mass (when stroke length = 0 mm) $m_1$	8.2	kg
Mass per mm of stroke $m_2$	12.5	g/mm
Total mass $m =$	$m_1 + H * m_2$	
Repeatability	0.05	mm
Maximum acceleration	5	$m/s^2$
Maximum travelling speed	1	m/s
Feed constant	20	mm/r

1 pce.

0.0.668.10

### Compatible drive elements

Plug-and-play Drive Set sizes	Universal Drive Set	Synchronising Set	Synchroniser Shaft Cover Set
60, 80	✓	✗	✗



## Overview of Linear Units LRE 8 D14 80x80 KGT

- Strong Roller Guide D14
- Two spindle leads available
- Precise positioning and payloads of up to 1600 N

Linear Units LRE 8 D14 80x80 KGT offer the excellent repeatability of a ball screw drive for applications with a high payload of up to 1600 N. The carriage is guided by strong roller elements with a diameter of D14 that run on hardened steel shafts.

Two spindle leads are available. The 5 mm lead translates a low drive torque into a very high operating force. The spindle lead of 20 mm enables a maximum speed of up to 1 m/s combined with a high operating load.

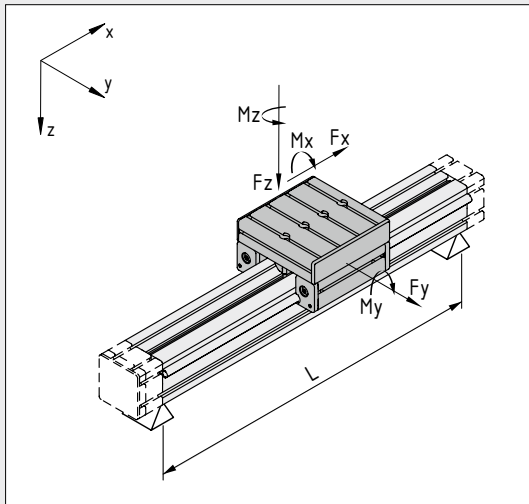

Linear Unit	Art. No.		Operating load Fx max [N]	Fy max [N]	Fz max [N]	Mx max [Nm]	My max [Nm]	Mz max [Nm]	Support width Lmax when Fz max [mm]	Support width Lmax when Fy max [mm]
Linear Unit LRE 8 D14 80x80 KGT 20x5	0.0.668.06	52	2000	2400	1600	76	64	96	1900	1700
Linear Unit LRE 8 D14 80x80 KGT 20x20	0.0.668.08	53	2000	2400	1600	76	64	96	1900	1700



### Linear Unit LRE 8 D14 80x80 KGT 20x5

- Precise with a high drive force coupled with a heavy payload
- Highly rigid drive

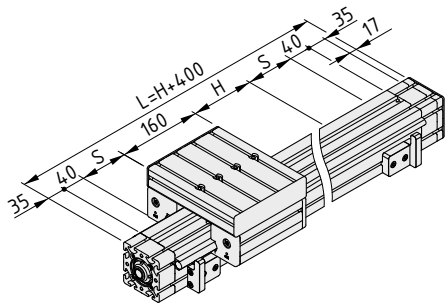
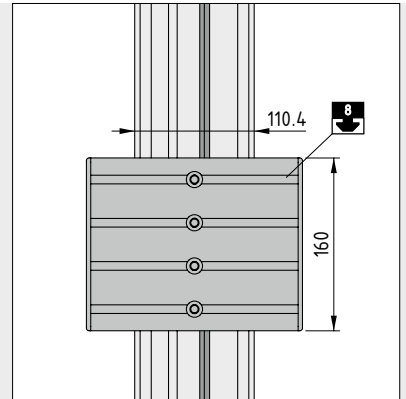
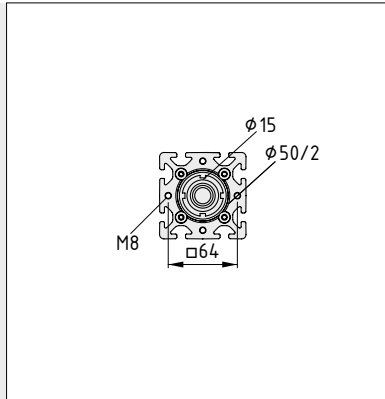
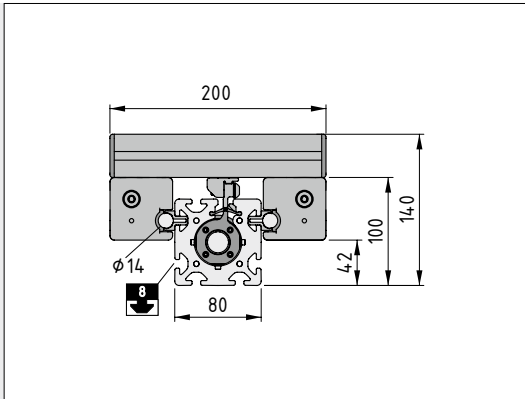

### Linear Unit LRE 8 D14 80x80 KGT 20x5



Maximum stroke $H_{max}$	2687	mm
Safety clearance S	76.5	mm
Basic mass (when stroke length = 0 mm) $m_1$	10.0	kg
Mass per mm of stroke $m_2$	14.3	g/mm
Total mass $m =$	$m_1 + H * m_2$	
Repeatability	0.05	mm
Maximum acceleration	5	$m/s^2$
Maximum travelling speed	0.25	m/s
Feed constant	5	mm/r

1 pce.

0.0.668.06

### Compatible drive elements

Plug-and-play Drive Set sizes	Universal Drive Set	Synchronising Set	Synchroniser Shaft Cover Set
60, 80	✓	✗	✗





### Linear Unit LRE 8 D14 80x80 KGT 20x20

- Precise – even with higher payloads
- Highly rigid drive

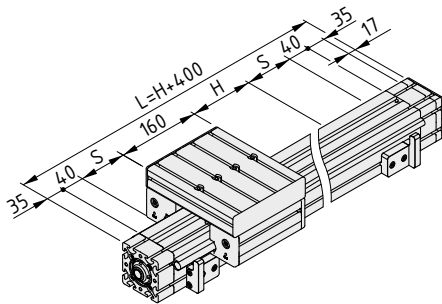
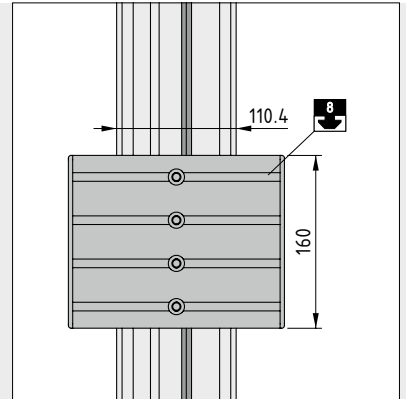
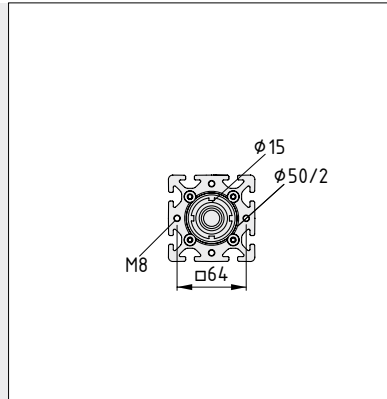
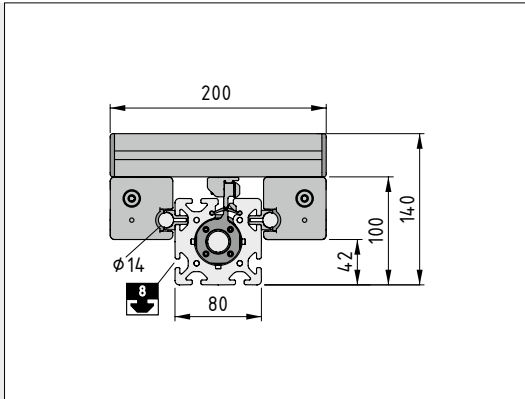

### Linear Unit LRE 8 D14 80x80 KGT 20x20



Maximum stroke $H_{max}$	2687	mm
Safety clearance S	76.5	mm
Basic mass (when stroke length = 0 mm) $m_1$	10.0	kg
Mass per mm of stroke $m_2$	14.0	g/mm
Total mass $m =$	$m_1 + H * m_2$	
Repeatability	0.05	mm
Maximum acceleration	5	$m/s^2$
Maximum travelling speed	1	m/s
Feed constant	20	mm/r

1 pce.

0.0.668.08

#### Compatible drive elements

Plug-and-play Drive Set sizes	Universal Drive Set	Synchronising Set	Synchroniser Shaft Cover Set
60, 80	✓	✗	✗



## Linear Units with a chain drive

It holds steady when others have given up. A chain drive is resistant to problems caused by soiling, can transfer high forces and is also ideal for vertical movements. The robust chain comes into use when absolute reliability is required, including under tough conditions.

Similar to a timing-belt drive, the rotary motion of the motor is transferred to a continuous chain. The drive cannot slip. Linear Units with a chain drive transfer large forces in the direction of travel, but are limited in terms of positioning and travel speed due to their design. However, they exhibit excellent failure load characteristics, which means chain drives are often used to build lifting doors and other vertical applications.

Because the force in a chain drive can be converted into movement via sprocket wheels positioned anywhere on the Linear Unit, this design is particularly well suited to building conveyor systems with rollers. In fact, there are hardly any alternative solutions in this application scenario.

Compared to other Linear Units, those that use steel link chains require slightly more maintenance work. It is also important to ensure the system is adequately lubricated and to check chain tension regularly.



## Linear Unit LRE 8 D14 80x40 KU 80

- Chain drive ensures consistently high power transmission
- Robust in heavily contaminated environments



Linear Unit LRE 8 D14 80x40 KU 80 is secure and virtually indestructible. The 1/2" roller chain delivers consistently high power transmission and a reliable hold when used in vertical applications. Even very heavy loads up to 1600 N are moved in a controlled manner and with powerful acceleration. Linear Unit LRE 8 D14 80x40 KU 80 can also be used in heavily contaminated environments.

					max. 1600 N
					up to 2 m/s
					max. 0.5 mm
					max. 5760 mm

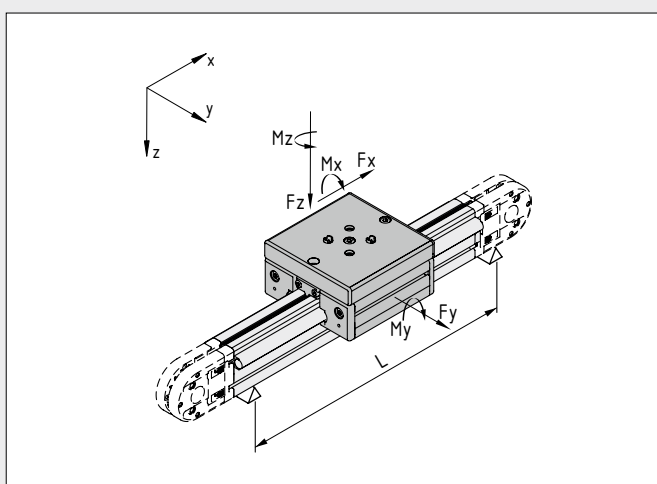

Linear Unit	Art. No.		Operating load $F_x$ max [N]	$F_y$ max [N]	$F_z$ max [N]	$M_x$ max [Nm]	$M_y$ max [Nm]	$M_z$ max [Nm]	Support width $L_{max}$ when $F_y$ max [mm]	Support width $L_{max}$ when $F_z$ max [mm]
Linear Unit LRE 8 D14 80x40 KU 80	0.0.664.54	55	620	2400	1600	40	64	96	600	1400

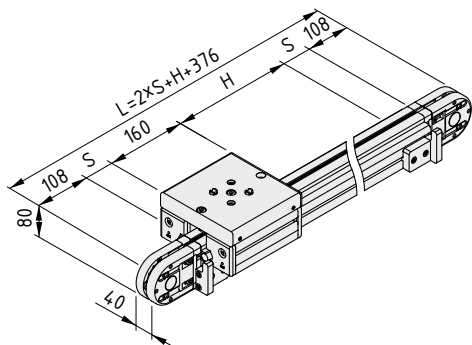
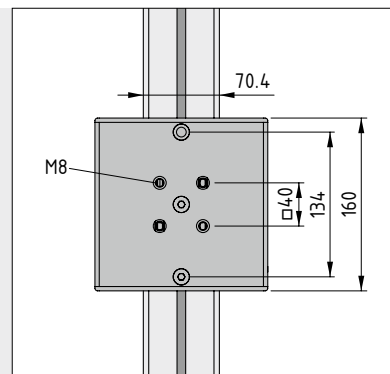
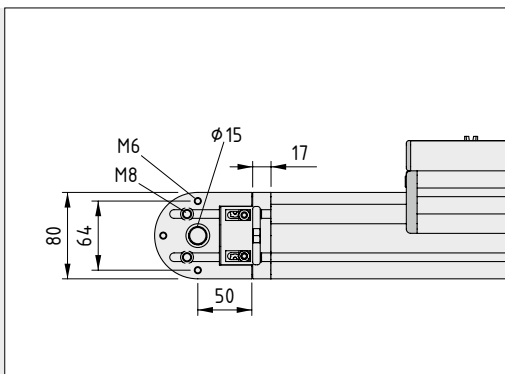
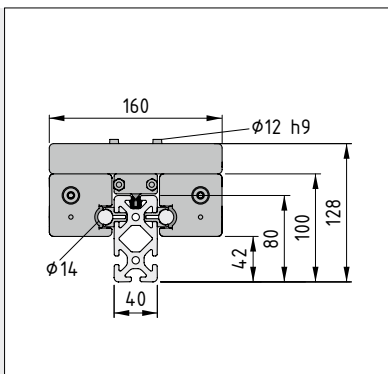

**Linear Unit LRE 8 D14 80x40 KU 80**



Maximum stroke $H_{max}$	5760	mm
Safety clearance S	12	mm
Basic mass (when stroke length = 0 mm) $m_1$	7.7	kg
Mass per mm of stroke $m_2$	8.1	g/mm
Total mass $m =$	$m_1 + H * m_2$	
Repeatability	0.5	mm
Maximum acceleration	5	$m/s^2$
Maximum travelling speed	2	m/s
Feed constant	203.2	mm/r

1 pce.

0.0.664.54

**Compatible drive elements**

Plug-and-play Drive Set size	Universal Drive Set	Synchronising Set	Synchroniser Shaft Cover Set
60	✓	✓	✗

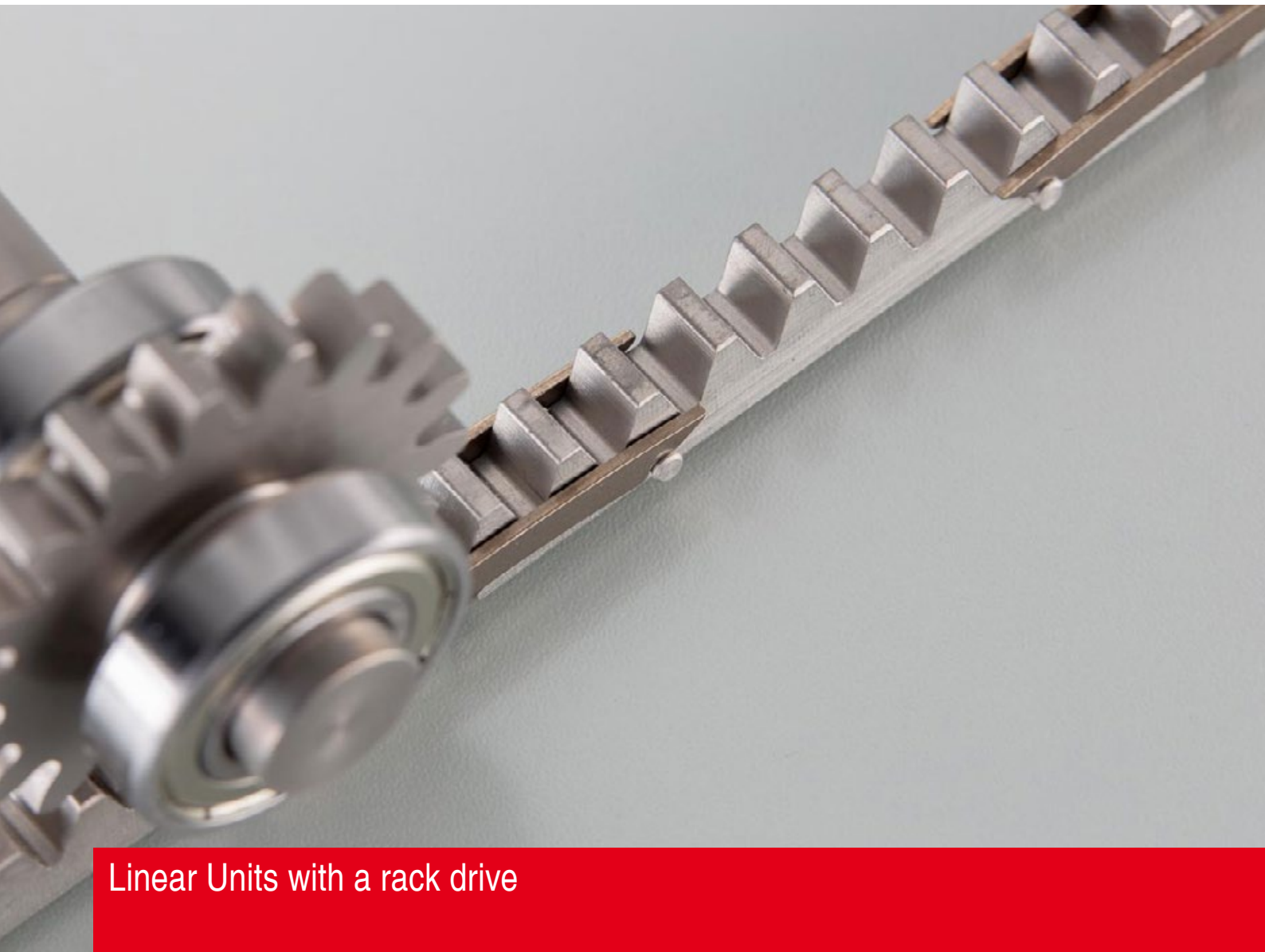

## Linear Units with a rack drive

A Linear Unit with a rack drive is often the best solution when a powerful stroke and precise control are required. The driven gearwheel interlocks with the straight rack to eliminate the possibility of slip. The rotary motion of the drive motor is thus converted directly into the rectilinear motion of the slide. This enables two applications: Either the load travels with the driven gearwheel, or the drive is locked and the load travels with the moving rack. In the item Automation System, the rack is completely concealed in the groove of the supporting profile. Drive is transmitted directly to the slide. Other applications can be engineered as special solutions using the MB Building Kit System.

The rack drive is a robust linear drive that can be used to move heavy loads. A high standard of positioning accuracy is obtained, even on long axes, as the rack does not stretch out when under load.

Linear units with a rack drive also transmit power securely in vertical applications.

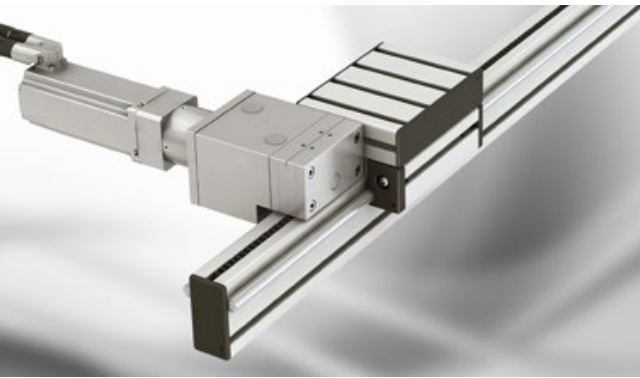

## Linear Unit LRE 8 D10 80x40 ZS K light

- Rack made from high-strength plastic
- Cost-effective solution with low base weight
- Straightforward assembly



Extra light and extra strong! Linear Unit LRE 8 D10 80x40 ZS K light uses a rack made of high-strength plastic. As a result, it is ideal for moving medium loads securely and quickly.

The Linear Unit features a low dead weight and excellent safety for vertical movements. The modular rack is made of fibre-glass reinforced plastic. It is safely concealed in the groove of a Profile 8 light and exhibits high rigidity and low coefficients of friction. The plastic ensures stability, smooth travel and corrosion resistance. The slide runs on a high-strength Double-Bearing Unit and hardened steel Shafts.

The low mass of the Support Profile and rack enable impressive dynamics, even during lifting movements. This combination is also a very economical solution for many tasks. Linear Unit LRE 8 D14 80x40 ZS with a metal rack is available as a rack system for moving larger masses.

Linear Unit LRE 8 D10 80x40 ZS K is supplied ready-to-install in the desired length. The plastic rack can also be ordered separately to build custom solutions.

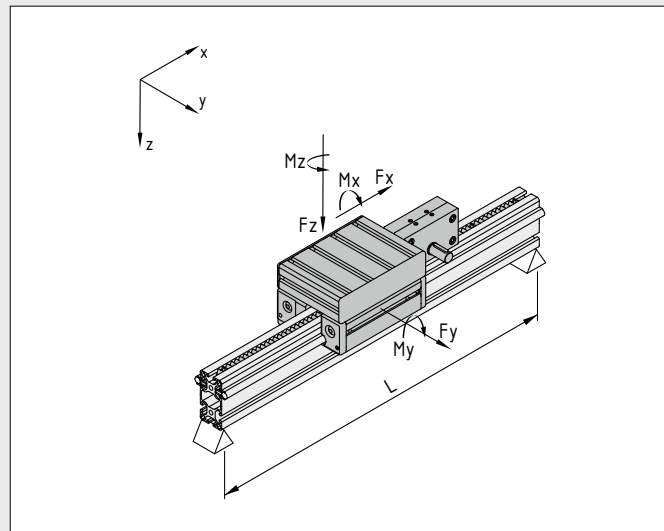

Linear Unit	Art. No.		Operating load $F_x$ max [N]	$F_y$ max [N]	$F_z$ max [N]	$M_x$ max [Nm]	$M_y$ max [Nm]	$M_z$ max [Nm]	Support width $L_{max}$ when $F_y$ max [mm]	Support width $L_{max}$ when $F_z$ max [mm]
Linear Unit LRE 8 D10 80x40 ZS K light	0.0.679.91	58	350	1300	880	22	35	52	600	1600

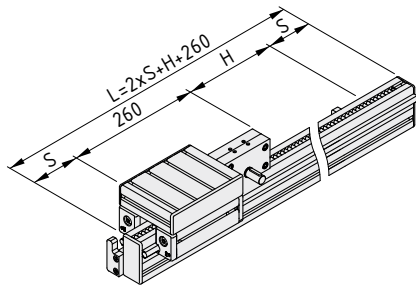
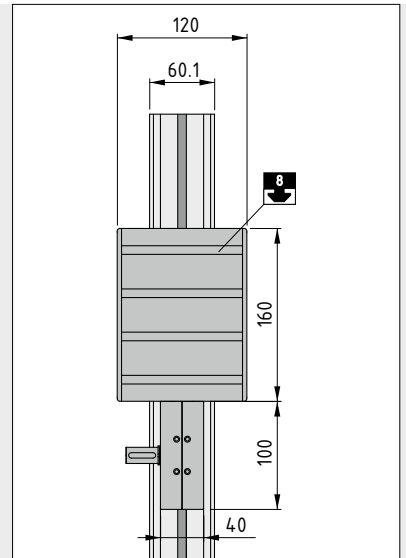
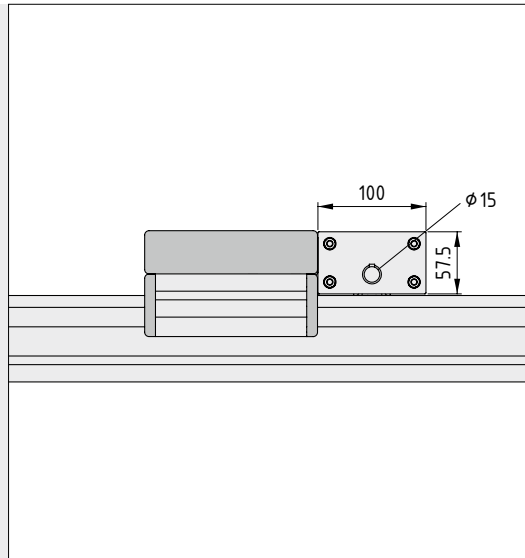
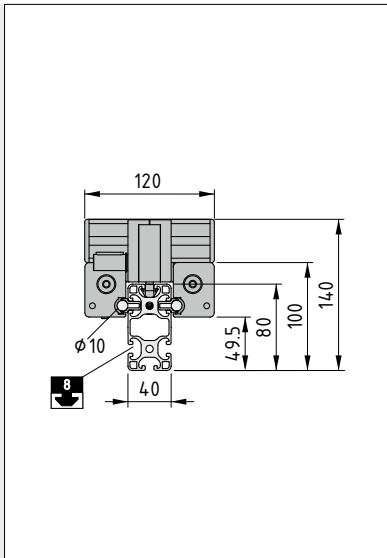

**Linear Unit LRE 8 D10 80x40 ZS K light**

Maximum stroke $H_{max}$	5678	mm
Safety clearance S	31	mm
Basic mass (when stroke length = 0 mm) $m_1$	5.1	kg
Mass per mm of stroke $m_2$	4.8	g/mm
Total mass $m =$	$m_1 + H \cdot m_2$	
Repeatability	0.5	mm
Maximum acceleration	5	$m/s^2$
Maximum travelling speed	3	m/s
Feed constant	144	mm/r

1 pce.

0.0.679.91

**Compatible drive elements**

Plug-and-play Drive Set sizes	Universal Drive Set	Synchronising Set	Synchroniser Shaft Cover Set
60, 80	✓	✗	✗





## Linear Unit LRE 8 D14 80x40 ZS

- Exceptional reliability for vertical movements
- Very rigid and strong
- Special lengths on request



Perfect for vertical movements! Linear Unit LRE 8 D14 80x40 ZS positions itself with a repeat accuracy of just 0.1 mm, even over very long travel distances. As the drive is mounted directly on the slide, it is very easy to build a vertical axis of movement, on which the slide is fixed and the rack is moved vertically. Roller guide D14 ensures that high forces and torques can be accommodated. Linear Unit LRE 8 D14 80x40 ZS can also be used in heavily contaminated environments.

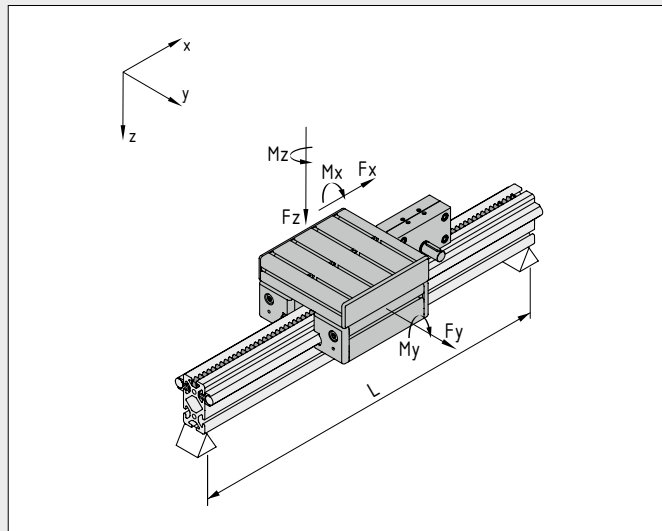

Linear Unit	Art. No.		Operating load $F_x$ max [N]	$F_y$ max [N]	$F_z$ max [N]	$M_x$ max [Nm]	$M_y$ max [Nm]	$M_z$ max [Nm]	Support width $L_{max}$ when $F_y$ max [mm]	Support width $L_{max}$ when $F_z$ max [mm]
Linear Unit LRE 8 D14 80x40 ZS	0.0.664.28	60	1000	2400	1600	40	64	96	600	1400

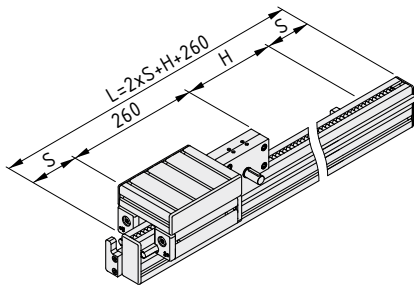
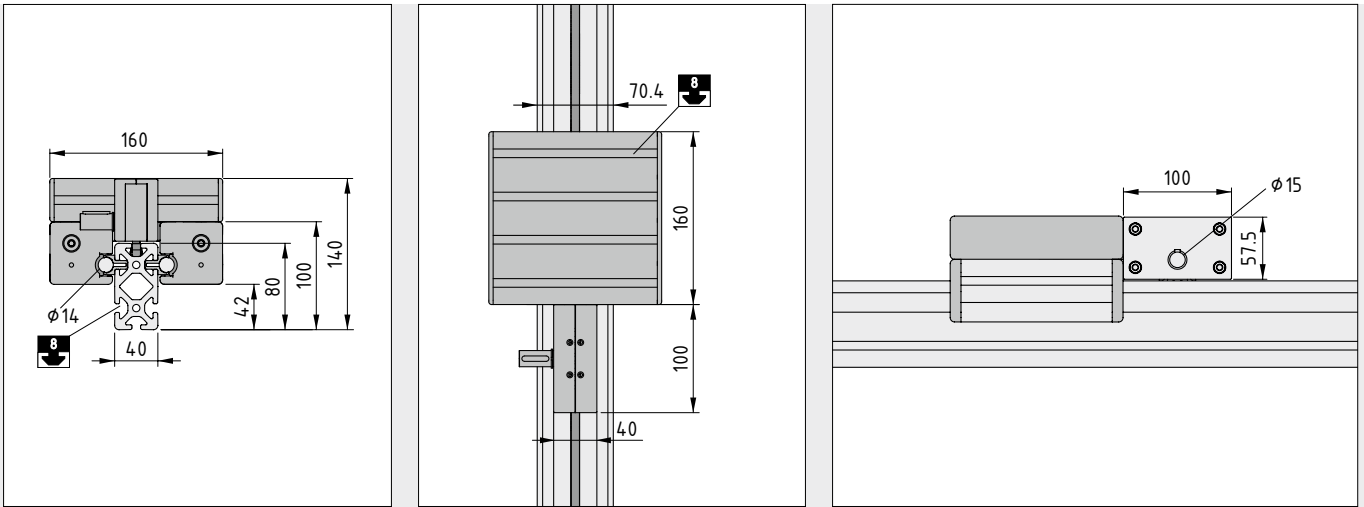

**Linear Unit LRE 8 D14 80x40 ZS**

Maximum stroke $H_{max}$	5678	mm
Safety clearance S	31	mm
Basic mass (when stroke length = 0 mm) $m_1$	7.4	kg
Mass per mm of stroke $m_2$	8.2	g/mm
Total mass $m =$	$m_1 + H * m_2$	
Repeatability	0.1	mm
Maximum acceleration	5	$m/s^2$
Maximum travelling speed	3	m/s
Feed constant	144	mm/r

1 pce.

0.0.664.28

**Compatible drive elements**

Plug-and-play Drive Set sizes	Universal Drive Set	Synchronising Set	Synchroniser Shaft Cover Set
60, 80	✓	✗	✗



## item MotionKits

The all-in-one solution for when things have to happen fast! item MotionKits give you everything you need for an automation project – Linear Unit, Motor, Drive Set, Controller and Cables. These turnkey solutions are available preconfigured in set stroke lengths. All components are coordinated and, when no custom design specifications are stipulated, can be ordered for an attractive package price.

This results in two clear options: Firstly, you can opt to use the item Automation System and item MotionDesigner® to stipulate every aspect of your solution yourself. Secondly, you can choose a ready-made item MotionKit that meets your requirements. Both

options – custom item linear motion units® and item MotionKits – use the same high-quality components.

item MotionKits offer all the benefits of the item Automation System. The drive is easy to program and the item Controller can be used with or without an overarching PLC. item MotionSoft® commissioning software makes it easy to get your system up and running and automatically optimises controller settings.

item MotionKits are also available with different Controllers. You can find out which series best suits your needs in the Controllers section.



Simply download it! item MotionSoft® helps you get a Linear Unit with Controller up and running straight away:  
[item24.com/en/service/download-center.html](http://item24.com/en/service/download-center.html)

## Products in this section



**MotionKits Linear Unit  
KGT 6 60 P20 - BL**

- Linear Units with a Ball Screw Unit
- All-in-one package with Controller BL

64



**MotionKits Linear Unit  
KGT 6 60 P20**

- Linear Units with a Ball Screw Unit
- All-in-one package with Controller C1

65



### item MotionKits Linear Unit KGT 6 60 P20 - BL

- All components in one turnkey package
- Stroke length 600, 1400 or 2600 mm
- With highly integrated Controller BL

item MotionKits Linear Unit KGT 6 60 P20 - BL give you everything you need for an automation project – the powerful and precise Linear Unit KGT 6 60 with a ball screw drive, a coordinated Motor and the dynamic Controller BL 1-04/C.

The highly integrated BL-series Controllers from item come with all key fieldbus interfaces and safety functions as standard. A Drive Set and Cables are also included in the all-in-one package so you can get started straight away.

item MotionKit BL is available in three set stroke lengths (600, 1400 and 2600 mm) for an attractive package price. This turnkey solution is available directly and, thanks to its three

standard lengths, can be easily factored into project costings.

item MotionKits offer all the benefits of the item Automation System. The Linear Unit is easy to program and the item Controller can be used with or without an overarching PLC. item MotionSoft® commissioning software makes it easy to get your system up and running and automatically optimises controller settings.

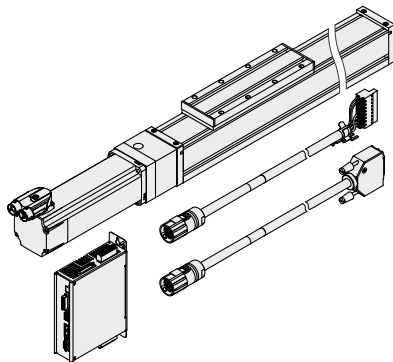

#### item MotionKit Linear Unit KGT 6 60 P20-600 - BL

- Linear Unit KGT 6 60 P20 – 600 mm stroke
- Drive Set KGT 6 60 SE 60
- Motor SE 60-150-3-60-AK-B
- Controller BL 1-04/C
- Power Cable BL SC1 04/5, orange
- Data Cable BL AKSC/5, green

1 set 0.0.709.17

#### item MotionKit Linear Unit KGT 6 60 P20-1400 - BL

- Linear Unit KGT 6 60 P20 – 1400 mm stroke
- Drive Set KGT 6 60 SE 60
- Motor SE 60-150-3-60-AK-B
- Controller BL 1-04/C
- Power Cable BL SC1 04/5, orange
- Data Cable BL AKSC/5, green

1 set 0.0.709.18

#### item MotionKit Linear Unit KGT 6 60 P20-2600 - BL

- Linear Unit KGT 6 60 P20 – 2600 mm stroke
- Drive Set KGT 6 60 SE 60
- Motor SE 60-150-3-60-AK-B
- Controller BL 1-04/C
- Power Cable BL SC1 04/5, orange
- Data Cable BL AKSC/5, green

1 set 0.0.709.19



## item MotionKits Linear Unit KGT 6 60 P20

- All components in one turnkey package
- Stroke length 600, 1400 or 2600 mm
- With modular Controller C1



item MotionKit Linear Unit KGT 6 60 P20 is an all-in-one package for automation projects that includes Linear Unit KGT 6 60 with a Motor, Drive Set, Controller and Cables. The item MotionKit is available in three set stroke lengths (600, 1400 and 2600 mm) for an attractive package price.

The modular item Controllers in the C series can be configured to suit requirements using plug-in cards. A Drive Set and Cables are also included in the all-in-one package so you can get started straight away.

As a turnkey solution, item MotionKit Linear Unit KGT 6 60 P20 is available directly and can be easily factored into projects thanks to its three standard lengths.

It provides all the benefits of the item Automation System in an all-in-one package. The Linear Unit is easy to program and the item Controller can be used with or without an overarching PLC. item MotionSoft® makes it easier to commission automation systems and independently optimizes controller settings. The interchangeable carriage plate with grooves allows users to connect a whole range of end devices or handling systems.

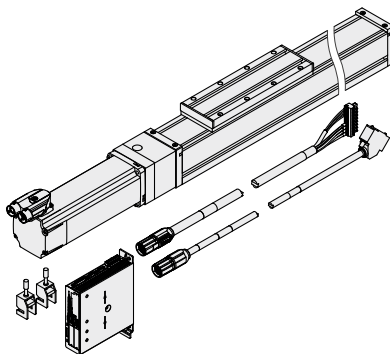

### item MotionKit Linear Unit KGT 6 60 P20-600



Linear Unit KGT 6 60 P20 – 600 mm stroke  
 Drive Set KGT 6 60 SE 60  
 Motor SE 60-150-3-60-AK-B  
 Controller C 1-02  
 Power Cable SC1 05/5, orange  
 Data Cable AKSC/5, green  
 Shield Terminal Block D14, bright zinc-plated

1 set 0.0.702.63

### item MotionKit Linear Unit KGT 6 60 P20-1400



Linear Unit KGT 6 60 P20 – 1400 mm stroke  
 Drive Set KGT 6 60 SE 60  
 Motor SE 60-150-3-60-AK-B  
 Controller C 1-02  
 Power Cable SC1 05/5, orange  
 Data Cable AKSC/5, green  
 Shield Terminal Block D14, bright zinc-plated

1 set 0.0.702.64

### item MotionKit Linear Unit KGT 6 60 P20-2600



Linear Unit KGT 6 60 P20 – 2600 mm stroke  
 Drive Set KGT 6 60 SE 60  
 Motor SE 60-150-3-60-AK-B  
 Controller C 1-02  
 Power Cable SC1 05/5, orange  
 Data Cable AKSC/5, green  
 Shield Terminal Block D14, bright zinc-plated

1 set 0.0.702.65



## Drive elements for Linear Units

There are compatible drive elements for every item Linear Unit. These transfer the torque to the Linear Unit via a friction-based connection, free from backlash. The Drive Sets comprise a coupling and housing. Due to the range of different hollow shaft and shaft diameters in use, the correct Drive Set has to be selected as appropriate to the Linear Unit in use. The information pages for the Linear Units state which Set is compatible. The durable item couplings are easy to fit and compensate for slight misalignments. They are available as ready-to-install plug-and-play variants or in a predrilled universal design for building custom solutions.

item Synchronising Sets are available for running several Linear Units in parallel (not available for Linear Units that use a ball screw unit or rack as a drive type). The compatible Synchronising Set is also stated on the information pages for the Linear Units.



**Note:**

You can find detailed technical information on installing couplings in the Annex, starting on Page 170.



## Products in this section



### Plug-and-play Drive Sets

- For connecting Gearboxes and Motors from item
- Coordinated components that can be used straight away

68

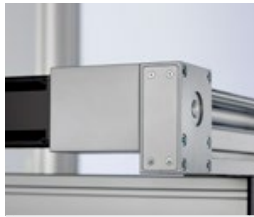

### Universal Drive Sets

- For connecting any drives
- Custom configuration and machining necessary

79



### Synchronising Sets

- Couplings for connecting synchronising shafts
- Parallel operation of two Linear Units

92



### Tubes for Synchronising Sets

- Available in three diameters
- Steel tubes for connections made via item Synchronising Sets

98



### Synchronising Shaft Profile

- Torsionally rigid aluminium tube for building synchronising shafts
- Prepared for connection via a multiple-spline shaft

99



### Synchroniser Shaft Cover Sets

- Adapter plates for the seamless connection of Conduit Profiles
- For Linear Units GSF, KLE and KRF

102



### Conduit and Lid Profiles

- Conduit Profiles made of aluminium as a secure cover for shafts
- Enclosure also keeps out dust and dirt

105



## Plug and play

All the components in the item Automation System are mutually compatible. This eases your workload considerably, as you don't need to machine the drive shaft or coupling to connect the Drive Set to the preassembled Linear Unit and Gearbox or Motor from item. Replacement parts can also be installed and used straight away because no additional machining steps are required.

## Universal

Universal Drive Sets connect your Linear Unit of choice to any drive. With custom machining, the coupling can accommodate the relevant drive shaft and ensure play-free power transmission. Please check the relevant diameter and the depth of insertion of the drive shaft. To ensure smooth running and avoid premature wear, it is important for the Coupling Halves to be aligned precisely.

## Plug-and-play Drive Sets

Linear Unit	Art. No.		Plug-and-play Drive Set Size 1	Art. No.		Plug-and-play Drive Set Size 2	Art. No.	
GSF 8 40 R10	0.0.655.98	20	Drive Set GSF 8 40 AP/WP 40	0.0.673.30	69	-	-	-
KLE 6 60x60 LR	0.0.605.07	22	Drive Set KLE 6 60x60 AP/WP 40	0.0.673.29	70	Drive Set KLE 6 60x60 AP/WP 60	0.0.673.28	70
KLE 8 80x80 LR	0.0.605.02	22	Drive Set KLE 8 80x80 AP/WP 60	0.0.673.26	71	Drive Set KLE 8 80x80 AP/WP 80	0.0.673.27	71
KRF 8 80x40 ZR, drive on right	0.0.648.66	25	Drive Set KRF 8 ZR AP/WP 60	0.0.673.31	72	Drive Set KRF 8 ZR AP/WP 80	0.0.673.32	72
KRF 8 80x40 ZR, drive on Left	0.0.641.21	25						
KRF 8 80x40 ZR, synchronous drive	0.0.648.69	25						
LRE 5 D6 60x20 ZU 40 R10	0.0.666.89	28	Drive Set ZU 5 40 D30/D12 AP/WP 40	0.0.672.74	73	-	-	-
LRE 8 D10 80x40 ZU 40 R25	0.0.662.70	30	Drive Set 8 D40/D15 AP/WP 60	0.0.672.73	75	-	-	-
LRE 8 D10 80x80 ZU 40 R25	0.0.663.32	30						
LRE 8 D14 80x40 ZU 40 R25	0.0.662.91	33						
LRE 8 D14 80x80 ZU 40 R25	0.0.663.25	33						
LRE 8 D14 120x80 ZU 40 R25	0.0.663.34	33						
LRE 8 D14 80x40 KU 80	0.0.664.54	55						
LRE 8 D14 80x40 ZU 80 R25	0.0.663.12	33	Drive Set ZU 8 80 D55/D34 AP/WP 60	0.0.672.75	73	Drive Set ZU 8 80 D55/D34 AP/WP 80	0.0.672.79	74
LRE 8 D14 80x80 ZU 80 R25	0.0.663.26	33						
LRE 8 D14 120x80 ZU 80 R25	0.0.663.35	33						
LRE 8 D25 120x80 ZU 80 R25	0.0.663.36	40						
LRE 8 D25 200x80 ZU 80 R25	0.0.666.53	40						
LRE 8 D25 120x80 ZU 80 R50	0.0.666.65	40	Drive Set ZU 8 80 D80/D34 AP/WP 80	0.0.672.76	74	-	-	-
LRE 8 D25 200x80 ZU 80 R50	0.0.666.66	40						
LRE 8 D10 80x40 ZS K light	0.0.679.91	58	Drive Set Rack 8 AP/WP 60	0.0.673.33	78	Drive Set Rack 8 AP/WP 80	0.0.673.34	78
LRE 8 D14 80x40 ZS	0.0.664.28	60						
KGT 6 60 P20	0.0.706.00	46	Drive Set KGT 6 60 SE 40	0.0.692.53	76	Drive Set KGT 6 60 SE 60	0.0.682.55	76
LRE 8 D10 80x80 KGT 20x5	0.0.668.12	48	Drive Set KGT D40/D15 SE 60	0.0.672.78	77	Drive Set KGT D40/D15 SE 80	0.0.672.77	77
LRE 8 D10 80x80 KGT 20x20	0.0.668.10	48						
LRE 8 D14 80x80 KGT 20x5	0.0.668.06	51						
LRE 8 D14 80x80 KGT 20x20	0.0.668.08	51						

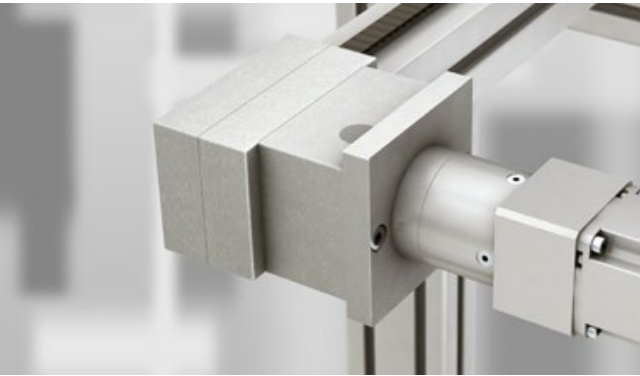

## Drive Set GSF 8 40 AP/WP

- Compatible with Linear Unit GSF
- No machining required
- Plug-and-play solution for item Motors

The Drive Set is configured for Linear Unit GSF.

The expanding hub coupling is supplied ready-to-install with a housing and can be fitted directly to the Linear Unit. The drive side is prepared for connecting an axial planetary Gearbox (AP) or a bevel planetary Gearbox (WP).

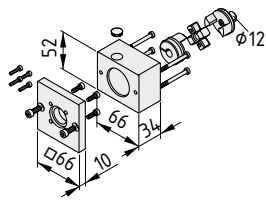

### Drive Set GSF 8 40 AP/WP 40

Coupling housing GSF 8, Al  
 Adapter plate GSF 8, for Gearbox AP/WP 40, Al  
 Coupling half D30/D10, for Gearbox AP/WP 40, Al  
 Expanding hub coupling half D30/D12, St and Al  
 Coupling insert D30, PU, blue  
 4 Hexagon Socket Head Cap Screws DIN 912-M3x10, St, bright zinc-plated  
 4 Hexagon Socket Head Cap Screws DIN 7984-M4x45, St, bright zinc-plated  
 4 Hexagon Socket Head Cap Screws DIN 912-M4x12, St, bright zinc-plated  
 2 Hexagon Socket Head Cap Screws DIN 912-M5x14, St, bright zinc-plated  
 Cap D30F, PA, grey  
 Tightening torque, expanding hub screw: 2.8 Nm  
 Tightening torque, clamping hub screw: 2 Nm  
 m = 411.0 g

1 set

0.0.673.30



## Drive Sets KLE AP/WP

- Compatible with Linear Units KLE
- No machining required
- Plug-and-play solution for item Motors

The Drive Sets are configured for Linear Units KLE in various sizes. The Coupling is supplied ready-to-install with a Housing and can be fitted directly to the Linear Unit. The drive side is prepared for connecting an Axial Planetary Gearbox (AP) or a Bevel Planetary Gearbox (WP). Various Drive Sets are available for the size of the drive in use.

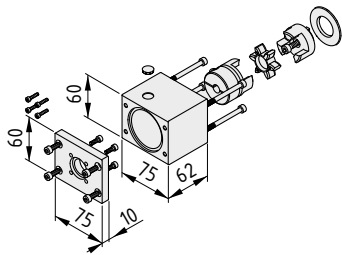

### Drive Set KLE 6 60x60 AP/WP 40

Coupling housing KLE 6 60x60, Al  
 Adapter plate KLE 6 60x60, for Gearbox AP/WP 40, Al  
 Coupling half D40 KLE 6 60x60, Al  
 Coupling half D40/D10, for Gearbox AP/WP 40, Al  
 Coupling insert D40, PU, green  
 Centring piece D40 KLE 6 60x60, St  
 4 Hexagon Socket Head Cap Screws DIN 912-M3x10, St, bright zinc-plated  
 4 Hexagon Socket Head Cap Screws DIN 912-M4x12, St, bright zinc-plated  
 4 Hexagon Socket Head Cap Screws DIN 912-M5x14, St, bright zinc-plated  
 4 Hexagon Socket Head Cap Screws DIN 912-M5x65, St, bright zinc-plated  
 Hexagon Socket Head Cap Screw DIN 912-M6x20, St, bright zinc-plated  
 Cap D30F, PA, grey  
 Tightening torque, coupling half D40 KLE 6 60x60, Al: 14 Nm  
 Tightening torque, clamping hub screw: 9.6 Nm  
 m = 807.0 g

1 set

0.0.673.29

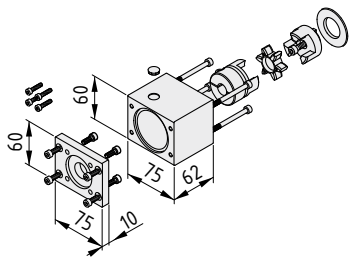

### Drive Set KLE 6 60x60 AP/WP 60

Coupling Housing KLE 6 60x60, Al  
 Adapter Plate KLE 6 60x60, for Gearbox AP/WP 60, Al  
 Coupling Half D40 KLE 6 60x60, Al  
 Coupling Half D40/D14, for Gearbox AP/WP 60, Al  
 Coupling Insert D40, PU, green  
 Centring Piece D40 KLE 6 60x60, St  
 4 Hexagon Socket Head Cap Screws DIN 912-M4x18, St, bright zinc-plated  
 8 Hexagon Socket Head Cap Screws DIN 912-M5x14, St, bright zinc-plated  
 4 Hexagon Socket Head Cap Screws DIN 912-M5x65, St, bright zinc-plated  
 Hexagon Socket Head Cap Screw DIN 912-M6x20, St, bright zinc-plated  
 Cap D30F, PA, grey  
 Tightening torque, Coupling Half D40 KLE 6 60x60, Al: 14 Nm  
 Tightening torque, clamping hub screw: 9.6 Nm  
 m = 812.0 g

1 set

0.0.673.28

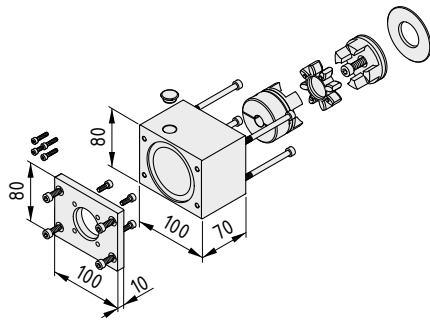

#### Drive Set KLE 8 80x80 AP/WP 60

Coupling housing KLE 8 80x80, Al  
 Adapter plate KLE 8 80x80, for Gearbox AP/WP 60, Al  
 Coupling half D55/D14, for Gearbox AP/WP 60, Al  
 Coupling half D55 KLE 8 80x80, Al  
 Coupling insert D55, PU, green  
 Centring piece D55 KLE 8 80x80, St  
 4 Hexagon Socket Head Cap Screws DIN 912-M4x18, St, bright zinc-plated  
 4 Hexagon Socket Head Cap Screws DIN 912-M5x14, St, bright zinc-plated  
 4 Hexagon Socket Head Cap Screws DIN 912-M6x16, St, bright zinc-plated  
 4 Hexagon Socket Head Cap Screws DIN 912-M6x85, St, bright zinc-plated  
 Hexagon Socket Head Cap Screw DIN 912-M8x25, St, bright zinc-plated  
 Cap 8 D15, PA, grey  
 Tightening torque, coupling half D55 KLE 8 80x80, Al: 25 Nm  
 Tightening torque, clamping hub screw: 9.6 Nm  
 m = 1.7 kg

1 set

0.0.673.26

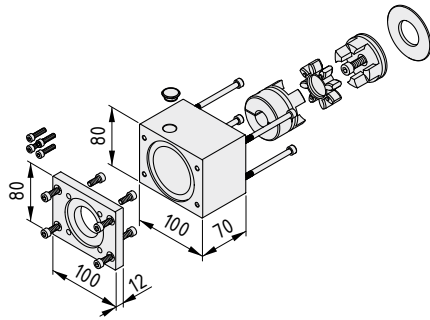

#### Drive Set KLE 8 80x80 AP/WP 80

Coupling Housing KLE 8 80x80, Al  
 Adapter Plate KLE 8 80x80, for Gearbox AP/WP 80, Al  
 Coupling Half D55/D20, for Gearbox AP/WP 80, Al  
 Coupling Half D55 KLE 8 80x80, Al  
 Coupling Insert D55, PU, green  
 Centring Piece D55 KLE 8 80x80, St  
 4 Hexagon Socket Head Cap Screws DIN 912-M5x20, St, bright zinc-plated  
 4 Hexagon Socket Head Cap Screws DIN 912-M6x15, St, bright zinc-plated  
 4 Hexagon Socket Head Cap Screws DIN 912-M6x16, St, bright zinc-plated  
 4 Hexagon Socket Head Cap Screws DIN 912-M6x85, St, bright zinc-plated  
 Hexagon Socket Head Cap Screw DIN 912-M8x25, St, bright zinc-plated  
 Cap 8 D15, PA, grey  
 Tightening torque, Coupling Half D55 KLE 8 80x80, Al: 25 Nm  
 Tightening torque, clamping hub screw: 9.6 Nm  
 m = 1.7 kg

1 set

0.0.673.27



## Drive Sets KRF AP/WP

- Compatible with Linear Unit KRF
- No machining required
- Plug-and-play solution for item Motors

The Drive Sets are configured for Linear Unit KRF.

The Coupling is supplied ready-to-install with a Housing and can be fitted directly to the Linear Unit. The drive side is prepared for connecting an Axial Planetary Gearbox (AP) or a Bevel Planetary Gearbox (WP).

Various Drive Sets are available for the size of the drive in use.

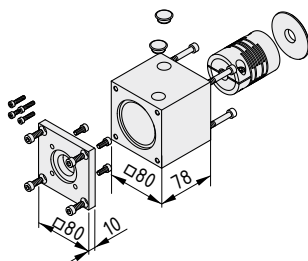

### Drive Set KRF 8 ZR AP/WP 60

Coupling Housing KRF 8 ZR, Al  
 Adapter Plate 8 80x80, for Gearbox AP/WP 60, Al  
 Self-aligning coupling D50/D14, St, for Gearbox AP/WP 60, stainless  
 Centre ring D32/D48, St  
 4 Hexagon Socket Head Cap Screws DIN 912-M4x18, St, bright zinc-plated  
 4 Hexagon Socket Head Cap Screws DIN 912-M5x12, St, bright zinc-plated  
 4 Hexagon Socket Head Cap Screws DIN 912-M6x16, St, bright zinc-plated  
 4 Hexagon Socket Head Cap Screws DIN 912-M6x50, St, bright zinc-plated  
 2 Caps D15, PA, grey  
 Tightening torque, clamping hub screw: 14.5 Nm  
 m = 1.8 kg

1 set

0.0.673.31

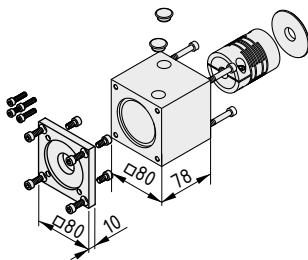

### Drive Set KRF 8 ZR AP/WP 80

Coupling Housing KRF 8 ZR, Al  
 Adapter Plate 8 80x80, for Gearbox AP/WP 80, Al  
 Self-aligning coupling D50/D20, St, stainless, for Gearbox AP/WP 80  
 Centre ring D32/D48, St  
 4 Hexagon Socket Head Cap Screws DIN 912-M5x20, St, bright zinc-plated  
 4 Hexagon Socket Head Cap Screws DIN 912-M6x12, St, bright zinc-plated  
 4 Hexagon Socket Head Cap Screws DIN 912-M6x16, St, bright zinc-plated  
 4 Hexagon Socket Head Cap Screws DIN 912-M6x50, St, bright zinc-plated  
 2 Caps D15, PA, grey  
 Tightening torque, clamping hub screw: 14.5 Nm  
 m = 1.2 kg

1 set

0.0.673.32

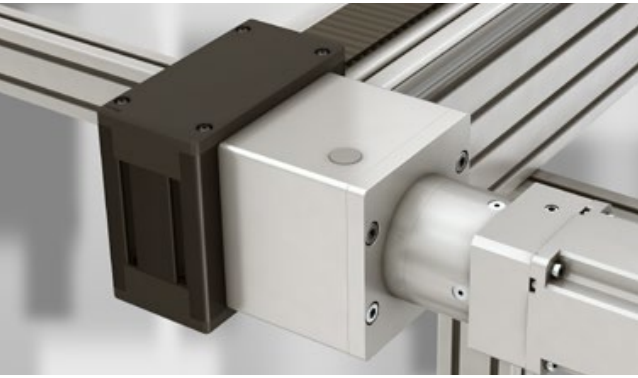

## Drive Sets ZU AP/WP

- Compatible with Linear Units with a timing-belt reverse unit (ZU)
- For hollow shaft diameters of 12 and 34 mm
- Machining-free plug-and-play solution for item Motors

The Drive Sets are configured for the Linear Units that feature a hollow shaft diameter of 12 or 34 mm.

The Coupling is supplied ready-to-install with a Housing and can be fitted directly to the Linear Unit. The drive side is prepared for connecting an Axial Planetary Gearbox (AP) or a Bevel Planetary Gearbox (WP).

Various Drive Sets are available for the size of the drive in use.

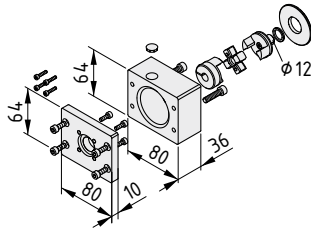

### Drive Set ZU 5 40 D30/D12 AP/WP 40

- Coupling Housing 5 D30, Al
- Adapter Plate 5 D30, for Gearbox AP/WP 40, Al
- Coupling Half D30/D10, for Gearbox AP/WP 40, Al
- Expanding hub coupling half D30/D12, St and Al
- Coupling Insert D30, PU, blue
- Spacer washer D12, Al
- Centring Piece D55-D22, St
- 4 Hexagon Socket Head Cap Screws DIN 912-M3x10, St, bright zinc-plated
- 4 Hexagon Socket Head Cap Screws DIN 912-M4x12, St, bright zinc-plated
- 4 Hexagon Socket Head Cap Screws DIN 912-M5x14, St, bright zinc-plated
- 2 Hexagon Socket Head Cap Screws DIN 912-M6x25, St, bright zinc-plated
- Cap D30F, PA, grey
- Tightening torque, expanding hub screw: 2.8 Nm
- Tightening torque, clamping hub screw: 2 Nm
- m = 557.0 g

1 set

0.0.672.74

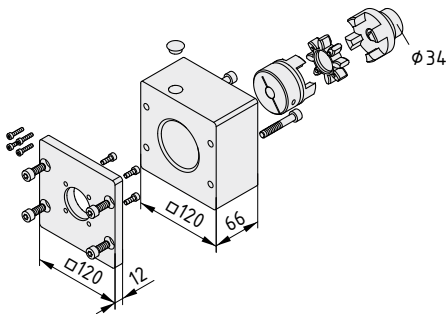

### Drive Set ZU 8 80 D55/D34 AP/WP 60

- Coupling Housing 8 D55, Al
- Adapter Plate 8 D55/D80, for Gearbox AP/WP 60, Al
- Coupling Half D55/D14, for Gearbox AP/WP 60, Al
- Expanding hub coupling half D55/D34, St and Al
- Coupling Insert D55, PU, green
- 4 Hexagon Socket Head Cap Screws DIN 912-M4x18, St, bright zinc-plated
- 4 Hexagon Socket Head Cap Screws DIN 912-M5x14, St, bright zinc-plated
- 4 Hexagon Socket Head Cap Screws DIN 912-M8x20, St, bright zinc-plated
- 2 Hexagon Socket Head Cap Screws DIN 912-M8x50, St, bright zinc-plated
- Cap D15, PA, grey
- Tightening torque, expanding hub screw: 23 Nm
- Tightening torque, clamping hub screw: 9.6 Nm
- m = 2.9 kg

1 set

0.0.672.75

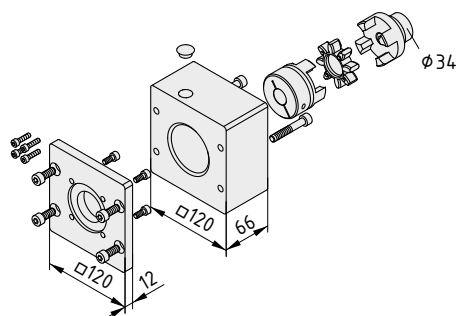

**Drive Set ZU 8 80 D55/D34 AP/WP 80**

Coupling Housing 8 D55, Al  
 Adapter Plate 8 D55/D80, for Gearbox AP/WP 80, Al  
 Coupling Half D55/D20, for Gearbox AP/WP 80, Al  
 Expanding hub coupling half D55/D34, St and Al  
 Coupling Insert D55, PU, green  
 4 Hexagon Socket Head Cap Screws DIN 912-M5x20, St, bright zinc-plated  
 4 Hexagon Socket Head Cap Screws DIN 912-M6x14, St, bright zinc-plated  
 4 Hexagon Socket Head Cap Screws DIN 912-M8x20, St, bright zinc-plated  
 2 Hexagon Socket Head Cap Screws DIN 912-M8x50, St, bright zinc-plated  
 Cap D15, PA, grey  
 Tightening torque, expanding hub screw: 23 Nm  
 Tightening torque, clamping hub screw: 9.6 Nm  
 m = 2.9 kg

1 set

0.0.672.79

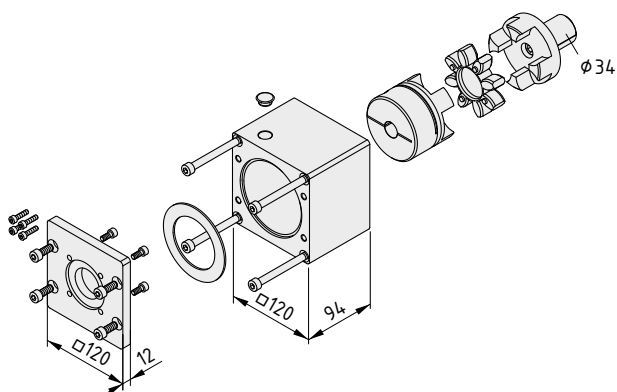
**Drive Set ZU 8 80 D80/D34 AP/WP 80**

Coupling Housing 8 D80, Al  
 Adapter Plate 8 D55/D80, for Gearbox AP/WP 80, Al  
 Coupling Half D80/D20, for Gearbox AP/WP 80, Al  
 Expanding hub coupling half D80/D34, St and Al  
 Coupling Insert D80, PU, red  
 Centring Piece D95-D65, St  
 4 Hexagon Socket Head Cap Screws DIN 912-M5x20, St, bright zinc-plated  
 4 Hexagon Socket Head Cap Screws DIN 912-M6x15, St, bright zinc-plated  
 4 Hexagon Socket Head Cap Screws DIN 912-M8x20, St, bright zinc-plated  
 4 Hexagon Socket Head Cap Screws DIN 912-M8x100, St, bright zinc-plated  
 Cap D15, PA, grey  
 Tightening torque, expanding hub screw: 49 Nm  
 Tightening torque, clamping hub screw: 23 Nm  
 m = 3.7 kg

1 set

0.0.672.76



## Drive Set 8 D40/D15 AP/WP

- Compatible with Linear Units with a hollow shaft diameter of 15 mm
- No machining required
- Plug-and-play solution for item Motors

The Drive Sets are configured for the Linear Units that feature a hollow shaft diameter of 15 mm.

The Coupling is supplied ready-to-install with a Housing and can be fitted directly to the Linear Unit. The drive side is prepared for connecting an Axial Planetary Gearbox (AP) or a Bevel Planetary Gearbox (WP).

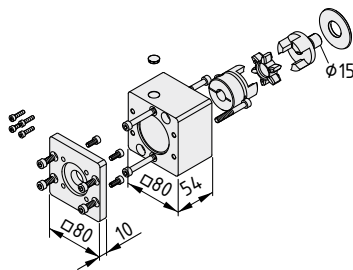

### Drive Set 8 D40/D15 AP/WP 60

- Coupling Housing 8 D40, Al
- Adapter Plate 8 D40, for Gearbox AP/WP 60, Al
- Coupling Half D40/D14, for Gearbox AP/WP 60, Al
- Expanding hub coupling half D40/D15, St and Al
- Coupling Insert D40, PU, green
- Centring Piece D50-D22, St
- 4 Hexagon Socket Head Cap Screws DIN 912-M4x16, St, bright zinc-plated
- 4 Hexagon Socket Head Cap Screws DIN 912-M5x12, St, bright zinc-plated
- 4 Hexagon Socket Head Cap Screws DIN 912-M6x16, St, bright zinc-plated
- 2 Hexagon Socket Head Cap Screws DIN 912-M6x45, St, bright zinc-plated
- 2 Hexagon Socket Head Cap Screws DIN 912-M6x60, St, bright zinc-plated
- Cap D30F, PA, grey
- Tightening torque, expanding hub screw: 9.6 Nm
- Tightening torque, clamping hub screw: 9.6 Nm
- m = 1.0 kg

1 set

0.0.672.73

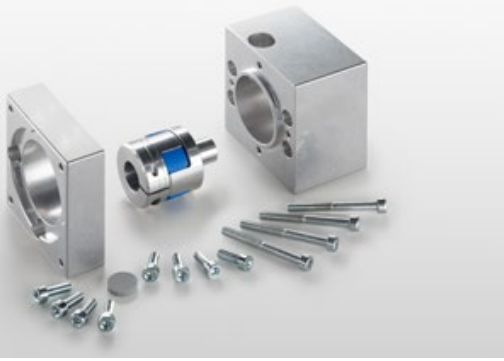

## Drive Sets KGT 6 60 SE

- Suitable for Linear Unit KGT 6 60 P20
- Direct connection without any machining
- Ready-to-install plug-and-play solution for item Motors

Drive Sets KGT 6 60 SE are configured for the compact Linear Unit KGT 6 60. They can be used to connect item Motors in 40 mm and 60 mm sizes without the need for additional machining.

To ensure maximum precision in spindle control, the Motor should be connected directly, without an additional Gearbox. An expanding hub ensures non-slip power transmission.

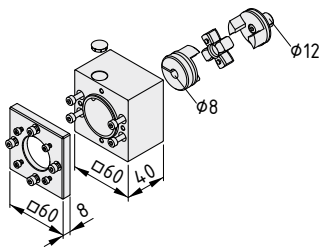

### Drive Set KGT 6 60 SE 40

Coupling Housing KGT 6 60, Al  
 Adapter plate KGT 6 60 SE 40, Al  
 Expanding hub coupling half D30/D12, St and Al  
 Coupling Insert D30, PU, blue  
 Coupling halves D30/D8, Al  
 4 Hexagon Socket Head Cap Screws DIN 912-M3x10, St, bright zinc-plated  
 4 Hexagon Socket Head Cap Screws DIN 912-M4x12, St, bright zinc-plated  
 4 Hexagon Socket Head Cap Screws DIN 912-M4x40, St, bright zinc-plated  
 Cap D30F, PA, grey  
 Tightening torque, expanding hub screw: 2.8 Nm  
 Tightening torque, clamping hub screw: 2 Nm  
 m = 407.0 g

1 set

0.0.692.53

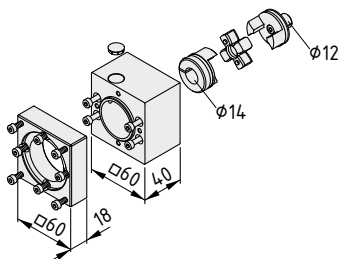

### Drive Set KGT 6 60 SE 60

Coupling Housing KGT 6 60, Al  
 Adapter plate KGT 6 60 SE 60, Al  
 Expanding hub coupling half D30/D12, St and Al  
 Coupling Insert D30, PU, blue  
 Coupling halves D30/D14, Al  
 4 Hexagon Socket Head Cap Screws DIN 912-M4x12, St, bright zinc-plated  
 4 Hexagon Socket Head Cap Screws DIN 912-M4x18, St, bright zinc-plated  
 4 Hexagon Socket Head Cap Screws DIN 912-M4x40, St, bright zinc-plated  
 Cap D30F, PA, grey  
 Tightening torque, expanding hub screw: 2.8 Nm  
 Tightening torque, clamping hub screw: 2 Nm  
 m = 460.0 g

1 set

0.0.692.55



## Drive Sets KGT D40/D15 SE

- For Linear Units with roller elements and a ball screw drive (LRE KGT)
- No machining required
- Ready-to-install plug-and-play solution for item Motors

The Drive Sets are configured for Linear Units equipped with roller elements and a ball screw drive (LRE KGT). To ensure maximum precision in spindle control, the Motor should be connected directly, without an additional Gearbox.

Various models are available depending on the performance class of the Motor.

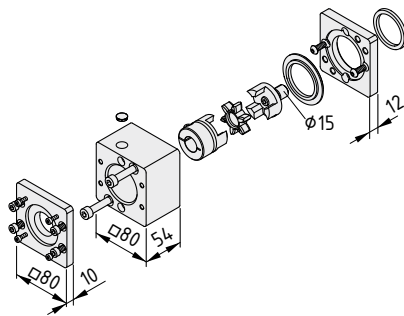

### Drive Set KGT D40/D15 SE 60

- Coupling Housing 8 D40, Al
- Adapter Plate 8 D40, for Motor SE 60, Al
- Coupling Adapter Plate D30/D55, Al
- Coupling Half D40/D14, for Motor SE 60, Al
- Expanding hub coupling half D40/D15, St and Al
- Coupling Insert D40, PU, green
- Centring Piece D63-D50, St
- Centring Piece D50-D50, St
- 4 Hexagon Socket Head Cap Screws DIN 912-M4x16, St, bright zinc-plated
- 4 Hexagon Socket Head Cap Screws DIN 912-M6x16, St, bright zinc-plated
- 2 Hexagon Socket Head Cap Screws DIN 912-M8x60, St, bright zinc-plated
- 2 Button-Head Screws ISO 7380-M6x16, St, bright zinc-plated
- Cap D30F, PA, grey
- Tightening torque, expanding hub screw: 9.6 Nm
- Tightening torque, clamping hub screw: 9.6 Nm
- m = 1.1 kg

1 set

0.0.672.78

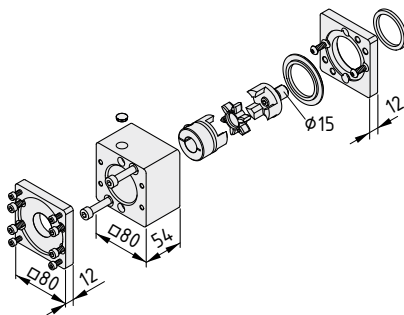

### Drive Set KGT D40/D15 SE 80

- Coupling Housing 8 D40, Al
- Adapter Plate 8 D40, for Motor SE 80, Al
- Coupling Adapter Plate D30/D55, Al
- Coupling Half D40/D19, for Motor SE 80, Al
- Expanding hub coupling half D40/D15, St and Al
- Coupling Insert D40, PU, green
- Centring Piece D63-D50, St
- Centring Piece D50-D50, St
- 4 Hexagon Socket Head Cap Screws DIN 912-M5x20, St, bright zinc-plated
- 4 Hexagon Socket Head Cap Screws DIN 912-M6x16, St, bright zinc-plated
- 2 Hexagon Socket Head Cap Screws DIN 912-M8x60, St, bright zinc-plated
- 2 Button-Head Screws ISO 7380-M6x16, St, bright zinc-plated
- Cap D30F, PA, grey
- Tightening torque, expanding hub screw: 9.6 Nm
- Tightening torque, clamping hub screw: 9.6 Nm
- m = 1.1 kg

1 set

0.0.672.77



## Drive Sets ZS AP/WP

- Compatible with Linear Units with a rack drive (ZS and ZS K)
- No machining required
- Ready-to-install plug-and-play solution for item Motors

The Drive Sets are configured for the Linear Units with a rack drive (ZS).

The Coupling is supplied ready-to-install with a Housing and can be fitted directly to the Linear Unit. The drive side is prepared for connecting an Axial Planetary Gearbox (AP) or a Bevel Planetary Gearbox (WP).

Various Drive Sets are available for the size of the drive in use.

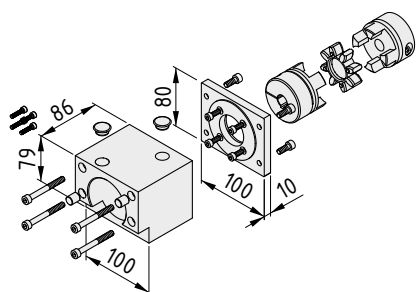

### Drive Set, Rack 8 AP/WP 60

Coupling Housing for Gearbox AP/WP 60, Al  
 Adapter Plate 8 80x80 for Gearbox AP/WP 60, Al  
 Coupling Half D55/D14, for Gearbox AP/WP 60, Al  
 Coupling Half D55/D15 PF, Al with parallel keyway  
 Coupling Insert D55, PU, green  
 2 centring sleeves, St  
 4 Hexagon Socket Head Cap Screws DIN 912-M4x18, St, bright zinc-plated  
 4 Hexagon Socket Head Cap Screws DIN 912-M5x14, St, bright zinc-plated  
 4 Hexagon Socket Head Cap Screws DIN 912-M6x16, St, bright zinc-plated  
 4 Hexagon Socket Head Cap Screws DIN 912-M6x55, St, bright zinc-plated  
 2 Caps 8 D15, PA, grey  
 Tightening torque, clamping hub screw: 9.6 Nm  
 m = 1.7 kg

1 set

0.0.673.33

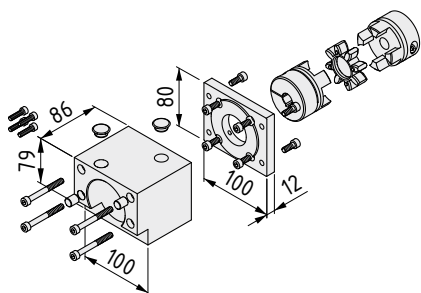

### Drive Set, Rack 8 AP/WP 80

Coupling Housing for Gearbox AP/WP 80, Al  
 Adapter Plate 8 80x80 for Gearbox AP/WP 80, Al  
 Coupling Half D55/D20, for Gearbox AP/WP 80, Al  
 Coupling Half D55/D15 PF, Al with parallel keyway  
 Coupling Insert D55, PU, green  
 2 centring sleeves, St  
 4 Hexagon Socket Head Cap Screws DIN 912-M5x20, St, bright zinc-plated  
 4 Hexagon Socket Head Cap Screws DIN 912-M6x15, St, bright zinc-plated  
 4 Hexagon Socket Head Cap Screws DIN 912-M6x16, St, bright zinc-plated  
 4 Hexagon Socket Head Cap Screws DIN 912-M6x55, St, bright zinc-plated  
 2 Caps 8 D15, PA, grey  
 Tightening torque, clamping hub screw: 9.6 Nm  
 m = 1.7 kg

1 set

0.0.673.34

## Universal Drive Sets

Linear Unit	Art. No.		Universal Drive Set	Art. No.	
GSF 8 40 R10	0.0.655.98	20	Drive Set GSF 8 40	0.0.654.23	80
KLE 6 60x60 LR	0.0.605.07	22	Drive Set KLE 6 60x60	0.0.609.80	82
KLE 8 80x80 LR	0.0.605.02	22	Drive Set KLE 8 80x80	0.0.609.77	82
KRF 8 80x40 ZR, drive on right	0.0.648.66	25	Drive Set KRF 8 ZR	0.0.627.46	83
KRF 8 80x40 ZR, drive on left	0.0.641.21	25			
KRF 8 80x40 ZR, synchronous drive	0.0.648.69	25			
LRE 5 D6 60x20 ZU 40 R10	0.0.666.89	28	Drive Set 5 40 D30/D12	0.0.662.49	85
LRE 8 D10 80x40 ZU 40 R25	0.0.662.70	30	Drive Set 8 40 D40/D15	0.0.668.02	86
LRE 8 D10 80x80 ZU 40 R25	0.0.663.32	30			
LRE 8 D14 80x40 ZU 40 R25	0.0.662.91	33			
LRE 8 D14 80x80 ZU 40 R25	0.0.663.25	33			
LRE 8 D14 120x80 ZU 40 R25	0.0.663.34	33			
LRE 8 D14 80x40 KU 80	0.0.664.54	55			
LRE 8 D14 80x40 ZU 80 R25	0.0.663.12	33	Drive Set 8 80 D55/D34	0.0.668.03	86
LRE 8 D14 80x80 ZU 80 R25	0.0.663.26	33			
LRE 8 D14 120x80 ZU 80 R25	0.0.663.35	33			
LRE 8 D25 120x80 ZU 80 R25	0.0.663.36	40			
LRE 8 D25 200x80 ZU 80 R25	0.0.666.53	40			
LRE 8 D25 120x80 ZU 80 R50	0.0.666.65	40	Drive Set 8 80 D80/D34	0.0.668.04	86
LRE 8 D25 200x80 ZU 80 R50	0.0.666.66	40			
LRE 8 D10 80x40 ZS K light	0.0.679.91	58	Rack 8 Coupling Module	0.0.621.73	91
LRE 8 D14 80x40 ZS	0.0.664.28	60			
KGT 6 60 P20	0.0.706.00	46	Drive Set KGT 6 60 universal	0.0.704.53	87
LRE 8 D10 80x80 KGT 20x5	0.0.668.12	48	Drive Set KGT D40/D15	0.0.667.76	89
LRE 8 D10 80x80 KGT 20x20	0.0.668.10	48			
LRE 8 D14 80x80 KGT 20x5	0.0.668.06	51			
LRE 8 D14 80x80 KGT 20x20	0.0.668.08	51			

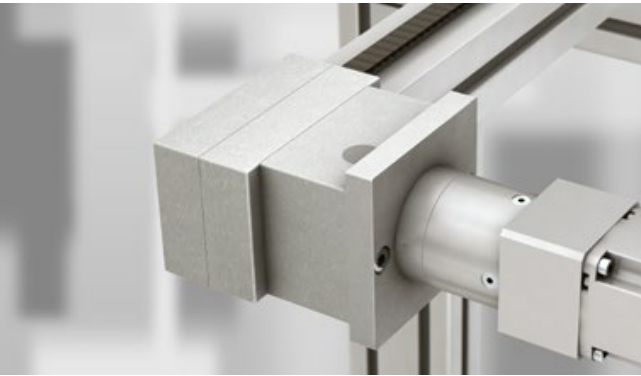

## Drive Set GSF 8 40

- For Linear Unit GSF
- Universal design allows connection of any drives

Drive Set GSF 8 40 can be used to connect any drives to Linear Unit GSF 8. The versatile coupling can be adapted for several different drive shafts and transfers drive torque without play. The maximum transferrable drive torque is 3 Nm.

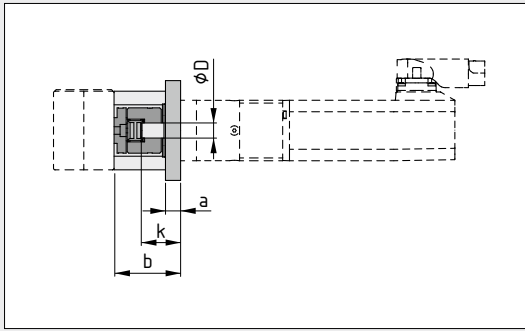

[mm]	GSF 8 40
a	10
b	44
Ø D	6-16
k	22-26.5

Information about installing couplings 170

Transferable torques depend on the clamping diameter 172

Linear Unit	Art. No.		Drive Set	Art. No.	
Linear Unit GSF 8 40 R10	0.0.655.98	20	Drive Set GSF 8 40	0.0.654.23	80

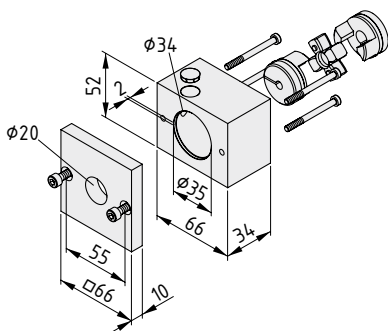

### Drive Set GSF 8 40

- Coupling housing GSF 8, Al
- Adapter plate GSF 8, Al
- D30/D6 coupling half, Al - reborable up to max. Ø 16 mm
- Expanding hub coupling half D30/D12, St and Al
- Coupling insert D30, PU, blue
- 4 Hexagon Socket Head Cap Screws DIN 7984-M4x45, St, bright zinc-plated
- 2 Hexagon Socket Head Cap Screws DIN 912-M5x14, St, bright zinc-plated
- Cap D30F, PA, grey
- Tightening torque, expanding hub screw: 2.8 Nm
- Tightening torque, clamping hub screw: 2 Nm
- m = 477.0 g

1 set	0.0.654.23
-------	------------





## Drive Sets KLE

- For Linear Units KLE
- Universal design allows connection of any drives

The relevant Drive Set is attached to the Drive Unit for driving a KLE. This Drive Set consists of a Coupling Half for connection to the pulley, a Coupling Half for connection to the motor shaft, a Coupling Housing with Adapter Plate for connecting the motor to the housing of the Drive Unit, a Centring Piece and fasteners.

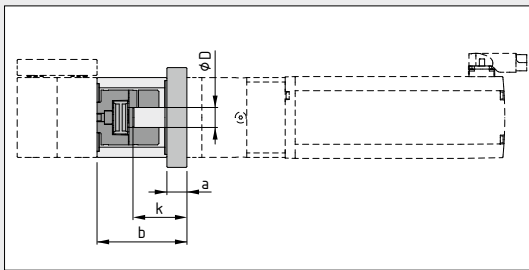

The prepared Coupling Half and the hub of the pulley are mechanically interlocked and bolted together. The elastic Coupling Insert transmits the drive torque free of play.



[mm]	KLE 6 60x60 LR	KLE 8 80x80 LR
a	18	20
b	80	90
Ø D	6-20	8-26
k	52-56	50-64

Information about installing couplings  170

Transferable torques depend on the clamping diameter  172

Linear Unit	Art. No.		Drive Set	Art. No.	
Linear Unit KLE 6 60x60 LR	0.0.605.07	23	Drive Set KLE 6 60x60	0.0.609.80	82
Linear Unit KLE 8 80x80 LR	0.0.605.02	24	Drive Set KLE 8 80x80	0.0.609.77	82

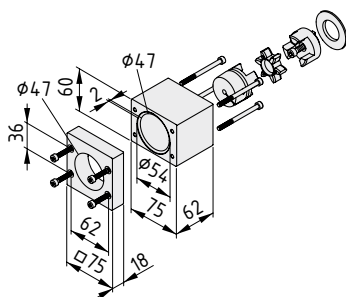
**Drive Set KLE 6 60x60**

Coupling housing KLE 6 60x60, Al  
 Adapter plate KLE 6 60x60, Al  
 Coupling half D40 KLE 6 60x60, Al  
 D40/D5 coupling half, Al - reborable up to max.  $\varnothing$ 20 mm  
 Coupling insert D40, PU, green  
 Centring piece D40 KLE 6 60x60, St  
 4 Hexagon Socket Head Cap Screws DIN 912-M5x25, St, bright zinc-plated  
 4 Hexagon Socket Head Cap Screws DIN 912-M5x65, St, bright zinc-plated  
 Hexagon Socket Head Cap Screw DIN 912-M6x20, St, bright zinc-plated  
 Tightening torque, coupling half D40 KLE 6 60x60, Al: 14 Nm  
 Tightening torque, clamping hub screw: 9.6 Nm  
 m = 911.0 g

1 set

0.0.609.80

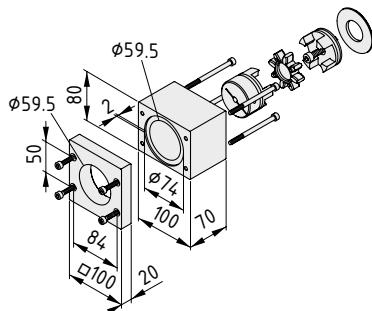
**Drive Set KLE 8 80x80**

Coupling housing KLE 8 80x80, Al  
 Adapter plate KLE 8 80x80, Al  
 D55/D8 coupling half, Al - reborable up to max.  $\varnothing$ 26 mm  
 Coupling half D55 KLE 8 80x80, Al  
 Coupling Insert D55, PU, green  
 Centring piece D55 KLE 8 80x80, St  
 4 Hexagon Socket Head Cap Screws DIN 912-M6x25, St, bright zinc-plated  
 4 Hexagon Socket Head Cap Screws DIN 912-M6x85, St, bright zinc-plated  
 Hexagon Socket Head Cap Screw DIN 912-M8x25, St, bright zinc-plated  
 Tightening torque, coupling half D55 KLE 8 80x80, Al: 25 Nm  
 Tightening torque, clamping hub screw: 9.6 Nm  
 m = 1.7 kg

1 set

0.0.609.77



## Drive Set KRF 8 ZR

- For Linear Units KRF
- Universal design allows connection of any drives

The Drive Set makes it easy to connect a wide variety of motors to the Drive Unit of the KRF. The stand-out features of this modular concept include limited machining requirements and friction-based torque transmission.

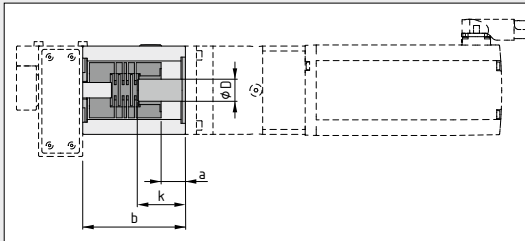

[mm]	KRF 8 ZR
a	22
b	93
Ø D	12 - 25
k	42 - 62

Information about installing couplings 170

Transferable torques depend on the clamping diameter 172

Linear Unit	Art. No.		Drive Set	Art. No.	
Linear Unit KRF 8 80x40 ZR, left-hand input shaft	0.0.641.21	25	Drive Set KRF 8 ZR	0.0.627.46	83
Linear Unit KRF 8 80x40 ZR, right-hand input shaft	0.0.648.66				
Linear Unit KRF 8 80x40 ZR, synchronous drive	0.0.648.69				

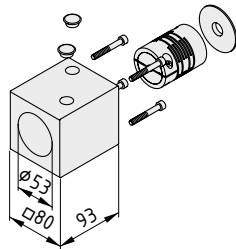

### Drive Set KRF 8 ZR

Coupling housing KRF 8 ZR, Al  
 Equaliser coupling D50, St, stainless - reborable up to max. Ø25 mm  
 Centring piece D32/D48, St  
 4 Hexagon Socket Head Cap Screws DIN 912-M6x50, St, bright zinc-plated  
 2 Caps D15, PA, grey  
 Tightening torque, clamping hub screw: 14.5 Nm  
 m = 1.9 kg

1 set

0.0.627.46



## Drive Sets LRE

- For Linear Units LRE
- Universal design allows connection of any drives

Drive Sets LRE from item connect the compact Linear Units LRE with a drive of the customer's choosing. This is made possible by an Adapter Plate that can be machined to suit any requirements. The central coupling bore can also be enlarged to match the drive shaft. Thanks to the integrated expanding hub coupling, the casing is particularly narrow. The Drive Set can be fitted to either side of the Timing-Belt Reverse Unit. Compatible Synchronising Sets from item can be used to operate two Linear Units in parallel with just one motor.

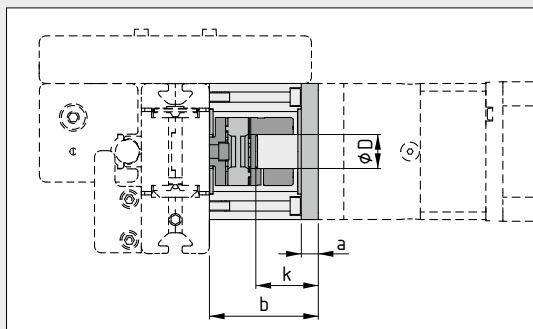

[mm]	Drive Set			
	5 40 D30/D12	8 40 D40/D15	8 80 D55/D34	8 80 D80/D34
a	10	10	12	12
b	46	64	78	106
Ø D	6 - 16	6 - 20	8 - 28	12 - 45
k	24 - 25.5	31.7 - 40	36.9 - 47	48.5 - 63.7

Information about installing couplings  170

Transferable torques depend on the clamping diameter  172

Linear Unit	Art. No.		Drive Set	Art. No.	
Linear Unit LRE 5 D6 60x20 ZU 40 R10	0.0.666.89	28	Drive Set 5 40 D30/D12	0.0.662.49	85
Linear Unit LRE 8 D10 80x40 ZU 40 R25	0.0.662.70	31	Drive Set 8 40 D40/D15	0.0.668.02	86
Linear Unit LRE 8 D10 80x80 ZU 40 R25	0.0.663.32	32			
Linear Unit LRE 8 D14 80x40 ZU 40 R25	0.0.662.91	34			
Linear Unit LRE 8 D14 80x80 ZU 40 R25	0.0.663.25	36			
Linear Unit LRE 8 D14 120x80 ZU 40 R25	0.0.663.34	38			
Linear Unit LRE 8 D14 80x40 KU 80	0.0.664.54	55			
Linear Unit LRE 8 D14 80x40 ZU 80 R25	0.0.663.12	35	Drive Set 8 80 D55/D34	0.0.668.03	86
Linear Unit LRE 8 D14 80x80 ZU 80 R25	0.0.663.26	37			
Linear Unit LRE 8 D14 120x80 ZU 80 R25	0.0.663.35	39			
Linear Unit LRE 8 D25 120x80 ZU 80 R25	0.0.663.36	41			
Linear Unit LRE 8 D25 200x80 ZU 80 R25	0.0.666.53	43			
Linear Unit LRE 8 D25 120x80 ZU 80 R50	0.0.666.65	42	Drive Set 8 80 D80/D34	0.0.668.04	86
Linear Unit LRE 8 D25 200x80 ZU 80 R50	0.0.666.66	44			

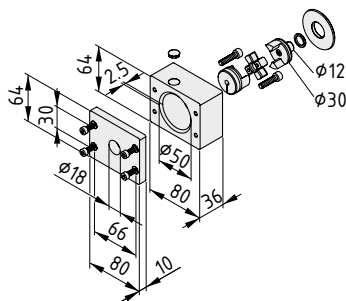

#### Drive Set 5 40 D30/D12

Coupling housing 5 D30, Al  
 Adapter plate 5 D30, Al  
 D30/D6 coupling half, Al - reborable up to max.  $\varnothing$  16 mm  
 Expanding hub coupling half D30/D12, St and Al  
 Coupling insert D30, PU, blue  
 Spacer washer D12, Al  
 Centring piece D55-D22, St  
 4 Hexagon Socket Head Cap Screws DIN 912-M5x14, St, bright zinc-plated  
 2 Hexagon Socket Head Cap Screws DIN 912-M6x25, St, bright zinc-plated  
 Cap D30F, PA, grey  
 Tightening torque, expanding hub screw: 2.8 Nm  
 Tightening torque, clamping hub screw: 2 Nm  
 m = 580.0 g

1 set

0.0.662.49

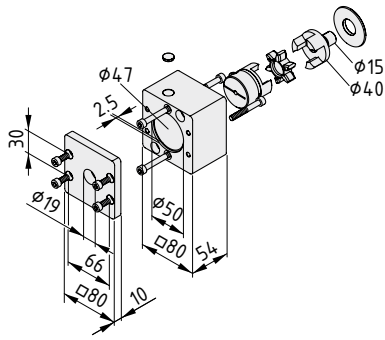
**Drive Set 8 40 D40/D15**

Coupling housing 8 D40, Al  
 Adapter plate 8 D40, Al  
 D40/D5 coupling half, Al – reborable up to max.  $\varnothing$ 20 mm  
 Expanding hub coupling half D40/D15, St and Al  
 Coupling insert D40, PU, green  
 Centring piece D50-D22, St  
 4 Hexagon Socket Head Cap Screws DIN 912-M6x16, St, bright zinc-plated  
 2 Hexagon Socket Head Cap Screws DIN 912-M6x45, St, bright zinc-plated  
 2 Hexagon Socket Head Cap Screws DIN 912-M6x60, St, bright zinc-plated  
 Cap D30F, PA, grey  
 Tightening torque, expanding hub screw: 9.6 Nm  
 Tightening torque, clamping hub screw: 9.6 Nm  
 m = 1.0 kg

1 set

0.0.668.02

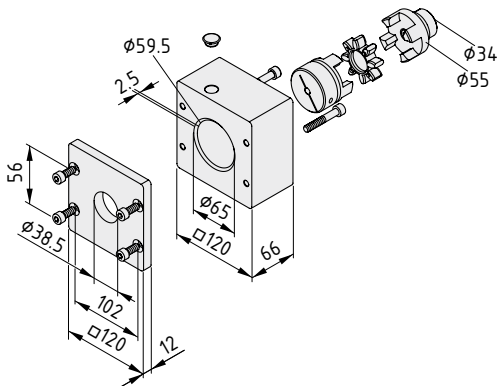
**Drive Set 8 80 D55/D34**

Coupling housing 8 D55, Al  
 Adapter plate 8 D55/D80, Al  
 D55/D8 coupling half, Al – reborable up to max.  $\varnothing$ 28 mm  
 Expanding hub coupling half D55/D34, St and Al  
 Coupling insert D55, PU, green  
 4 Hexagon Socket Head Cap Screws DIN 912-M8x20, St, bright zinc-plated  
 2 Hexagon Socket Head Cap Screws DIN 912-M8x50, St, bright zinc-plated  
 Cap D15, PA, grey  
 Tightening torque, expanding hub screw: 23 Nm  
 Tightening torque, clamping hub screw: 9.6 Nm  
 m = 2.9 kg

1 set

0.0.668.03

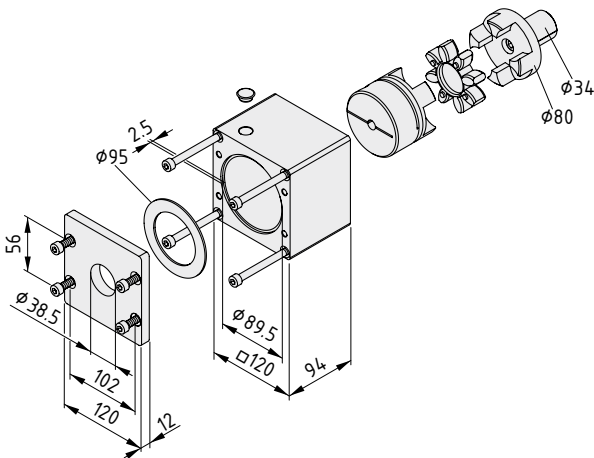
**Drive Set 8 80 D80/D34**

Coupling housing 8 D80, Al  
 Adapter plate 8 D55/D80, Al  
 D80/D12 coupling half, Al – reborable up to max.  $\varnothing$ 45 mm  
 Expanding hub coupling half D80/D34, St and Al  
 Coupling insert D80, PU, red  
 Centring piece D95-D65, St  
 4 Hexagon Socket Head Cap Screws DIN 912-M8x20, St, bright zinc-plated  
 4 Hexagon Socket Head Cap Screws DIN 912-M8x100, St, bright zinc-plated  
 Cap D15, PA, grey  
 Tightening torque, expanding hub screw: 49 Nm  
 Tightening torque, clamping hub screw: 23 Nm  
 m = 3.8 kg

1 set

0.0.668.04



## Drive Set KGT 6 60 - universal

- For Linear Unit KGT 6 60 P20
- Universal connection of any drives

Drive Set KGT 6 60 universal has been optimised for the item Linear Units KGT 6 60 with a ball screw drive. It connects them with a drive of the customer's choosing. This is made possible by an adapter plate that can be machined to suit any requirements. The central coupling bore can also be enlarged to match the drive shaft.

Thanks to the integrated expanding hub coupling, the housing is particularly narrow.

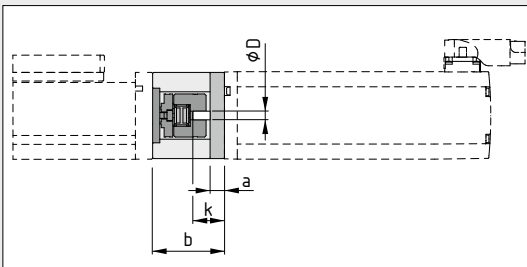

[mm]	KGT 6 60
a	10
b	50
∅ D	6-16
k	23-24.5

Information about installing couplings 170

Transferable torques depend on the clamping diameter 172

Linear Unit	Art. No.		Drive Set	Art. No.	
Linear Unit KGT 6 60 P20	0.0.706.00	46	Drive Set KGT 6 60 - universal	0.0.704.53	87

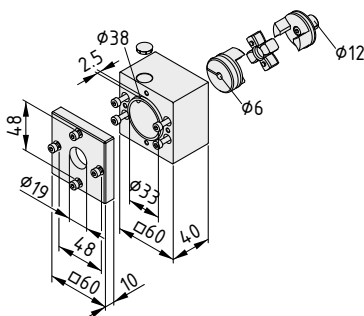

### Drive Set KGT 6 60 - universal

Coupling Housing KGT 6 60, Al  
 Adapter plate KGT 6 60 Universal, Al  
 Expanding hub coupling half D30/D12, St and Al  
 Coupling Insert D30, PU, blue  
 D30/D6 coupling halves, Al - reborable up to max. ∅ 16 mm  
 4 Hexagon Socket Head Cap Screws DIN 912 M4x12, St, bright zinc-plated  
 4 Hexagon Socket Head Cap Screws DIN 912 M4x40, St, bright zinc-plated  
 Cap D30F, PA, grey  
 Tightening torque, expanding hub screw: 2.8 Nm  
 Tightening torque, clamping hub screw: 2 Nm  
 η = 100%      m = 427.0 g

1 set

0.0.704.53





## Drive Set KGT D40/D15

- For Linear Units with roller elements and a ball screw drive (LRE KGT)
- Universal design allows connection of any drives

Drive Set KGT D40/D15 has been optimised for item Linear Units with roller elements and a ball screw drive (LRE KGT). It connects them with a drive of the customer's choosing. This is made possible by an adapter plate that can be machined to suit any requirements. The central coupling bore can also be enlarged to match the drive shaft. Thanks to the integrated expanding hub coupling, the housing is particularly narrow.

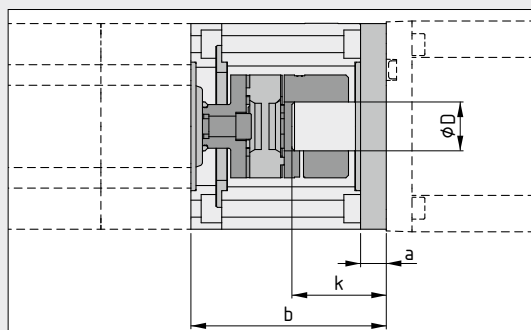

[mm]	KGT D40/D15
a	10
b	76
Ø D	8 - 20
k	32.2 - 40.5

Information about installing couplings [170](#)

Transferable torques depend on the clamping diameter [172](#)

Linear Unit	Art. No.		Drive Set	Art. No.	
Linear Unit LRE 8 D10 80x80 KGT 20x5	0.0.668.12	49	Drive Set KGT D40/D15	0.0.667.76	88
Linear Unit LRE 8 D10 80x80 KGT 20x20	0.0.668.10	50			
Linear Unit LRE 8 D14 80x80 KGT 20x5	0.0.668.06	52			
Linear Unit LRE 8 D14 80x80 KGT 20x20	0.0.668.08	53			

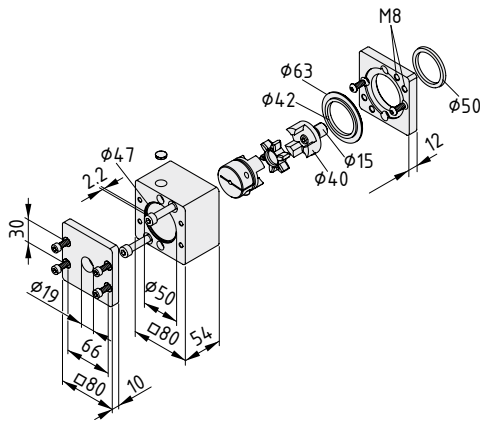

### Drive Set KGT D40/D15

- Coupling housing 8 D40, Al
- Adapter plate 8 D40, Al
- Coupling adapter plate D30/D55, Al
- D40/D5 coupling half, Al - reborable up to max.  $\varnothing 24$  mm
- Expanding hub coupling half D40/D15, St and Al
- Coupling insert D40, PU, green
- Centring piece D63-D50, St
- Centring Piece D50-D50, St
- 4 Hexagon Socket Head Cap Screws DIN 912-M6x16, St, bright zinc-plated
- 2 Hexagon Socket Head Cap Screws DIN 912-M8x60, St, bright zinc-plated
- 2 Button-Head Screws ISO 7380-M6x16, St, bright zinc-plated
- Cap D30F, PA, grey
- Tightening torque, expanding hub screw: 9.6 Nm
- Tightening torque, clamping hub screw: 9.6 Nm
- m = 1.2 kg

1 set

0.0.667.76



## Drive Set ZS

- Carriage driven directly via the rack
- Flexible coupling for connecting virtually any motor
- For Linear Units LRE
- Universal design allows connection of any drives

Drive force is transmitted to the rack from the carriage of the linear guide. As a result, the drive is fastened directly to the carriage. If the carriage is to move, a cable chain is required.

The Coupling Module comes with a universal coupling for connecting virtually any drive, which is connected directly to the Coupling Module's housing.

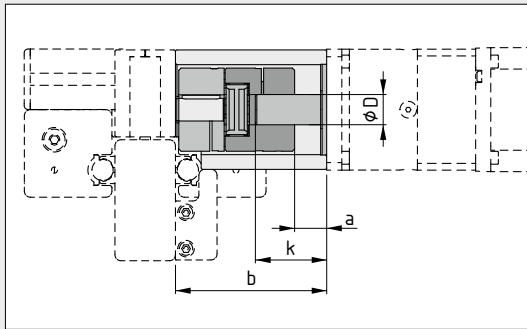



[mm]	ZS
a	21.2
b	100
ø D	8 - 28
k	43 - 51

Information about installing couplings  170

Transferable torques depend on the clamping diameter  172



This universal Coupling Module simply fits - machine the housing and coupling to suit your needs. When doing so, take care to note how far the shaft extends into the coupling half.

Linear Unit	Art. No.		Drive Set	Art. No.	
Linear Unit LRE 8 D14 80x40 ZS	0.0.664.28	60	Rack 8 Coupling Module	0.0.621.73	91

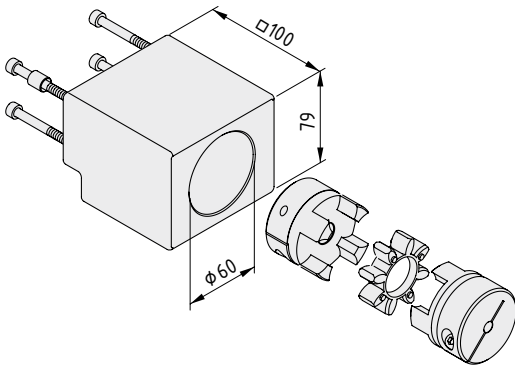

### Rack 8 Coupling Module

Coupling housing, Al, white aluminium  
Coupling set D55  
Screws, fastening elements and centring sleeves  
Tightening torque, clamping hub screw: 9.6 Nm  
m = 1.7 kg

1 set

0.0.621.73

## Synchronising Sets

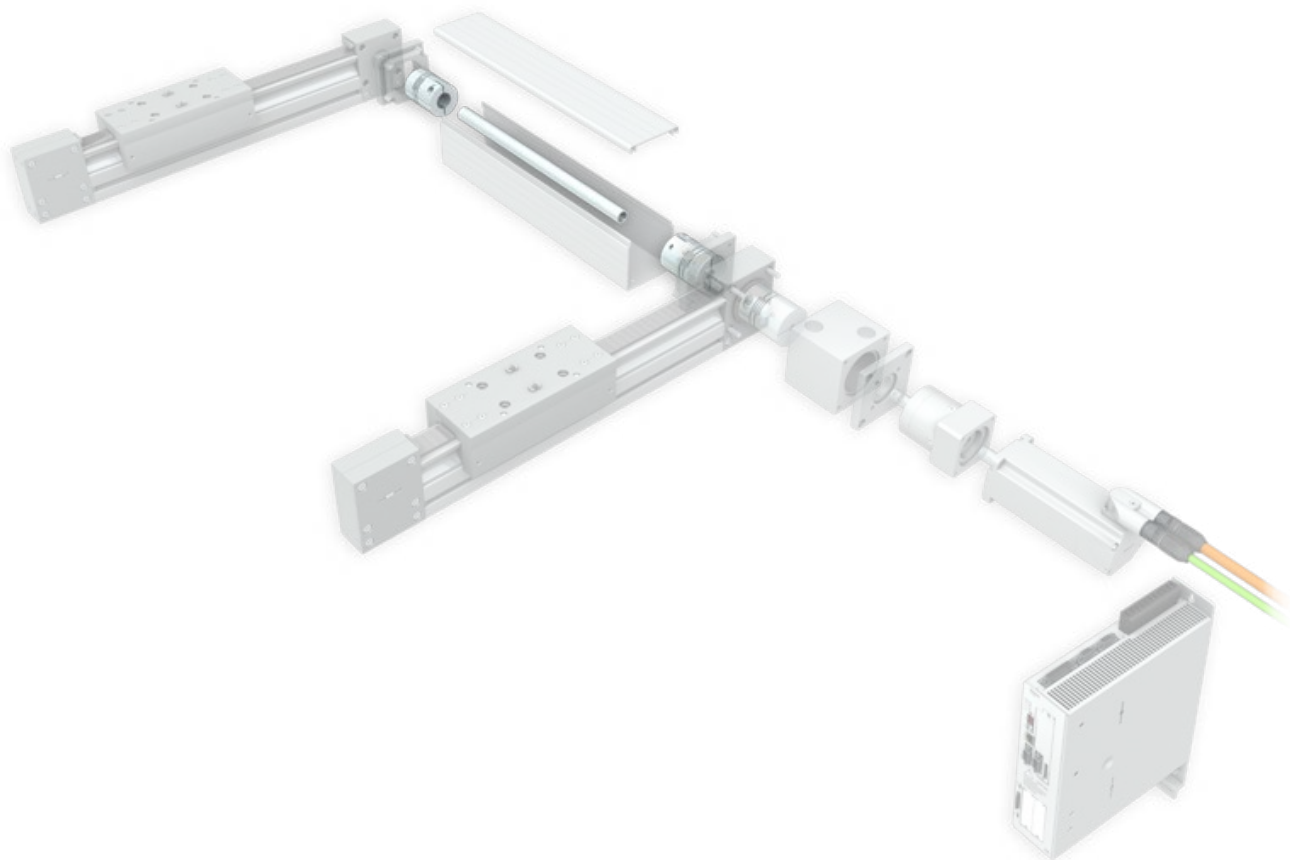

Synchronising Sets are used when two Linear Units are to be run in parallel. item Synchronising Sets comprise couplings that are fitted between two Linear Units and are connected by a synchroniser shaft that has been manufactured in the appropriate length. This ensures that the end result is a highly customised and flexible design. The Synchroniser Shaft Cover Sets from item are a useful accessory as they stop the synchroniser shaft coming into contact with external influences and keep dirt out, thereby boosting operational reliability.



## Synchronising Set GSF 8 40 R10

- Configured for Linear Unit GSF
- Non-slip expanding hub coupling

Synchronising Set GSF 8 40 R10 combines two Linear Units GSF 8 40 (0.0.655.98) to form one functional unit. A synchroniser shaft transmits the torque of the motor to both units.

Linear Unit	Art. No.		Synchronising Set	Art. No.	Accessories	
Linear Unit GSF 8 40 R10	0.0.655.98	20	Synchronising Set GSF 8 40 R10	0.0.662.95	0.0.664.14	93

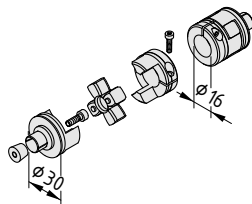

### Synchronising Set GSF 8 40 R10

2 coupling halves D30/D16, Al  
 2 expanding hub coupling halves D30/D12, St and Al  
 2 coupling inserts D30, PU, blue  
 Tightening torque, expanding hub screw: 2.8 Nm  
 Tightening torque, clamping hub screw: 2 Nm  
 m = 91.0 g

1 set	0.0.662.95
-------	------------





## Synchronising Sets KLE

- Configured for Linear Units KLE
- Available in two sizes

Synchronising Sets are available to synchronise two Linear Units KLE. Each of these contains two coupling sets for connecting the pulleys of the timing-belt drives.

**Note:** When designing the drive for synchronised KLEs, the maximum permissible drive torques of the Linear Unit must be taken into account.

Linear Unit	Art. No.		Synchronising Set	Art. No.	Accessories	
Linear Unit KLE 6 60x60 LR	0.0.605.07	23	Synchronising Set KLE 6 60x60	0.0.609.81	0.0.609.86	94
Linear Unit KLE 8 80x80 LR	0.0.605.02	24	Synchronising Set KLE 8 80x80	0.0.609.78	0.0.609.83	94

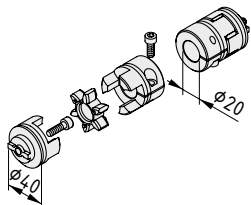

### Synchronising Set KLE 6 60x60

2 Coupling Halves D40/D20, Al  
 2 Coupling Halves D40 KLE 6 60x60, Al  
 2 Coupling Inserts D40, PU, green  
 2 Hexagon Socket Head Cap Screws DIN 912-M6x20, St, bright zinc-plated  
 Tightening torque, Coupling Halves D40 KLE 6 60x60, Al: 14 Nm  
 Tightening torque, clamping hub screw: 9.6 Nm  
 m = 285.0 g

1 set

0.0.609.81

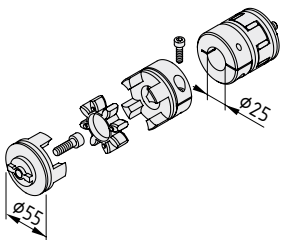

### Synchronising Set KLE 8 80x80

2 Coupling Halves D55/D25, Al  
 2 Coupling Halves D55 KLE 8 80x80, Al  
 2 Coupling Inserts D55, PU, green  
 Tightening torque, Coupling Halves D55 KLE 8 80x80, Al: 25 Nm  
 Tightening torque, clamping hub screw: 9.6 Nm  
 m = 715.0 g

1 set

0.0.609.78



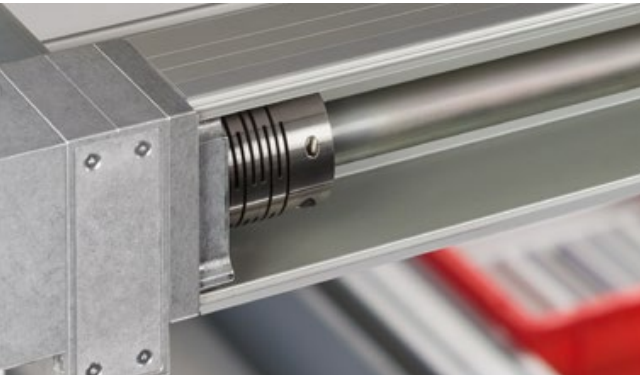

## Synchronising Set KRF 8 80 ZR

- Configured for Linear Units KRF
- Can be used for both drive positions

The robust equaliser couplings made from stainless steel connect the synchronising shaft to Linear Units KRF. Tube D25x3 (0.0.609.83) is required as a shaft.

**Note:** To make installation easier, the protective layer of zinc should be removed from the ends of the steel tube.

Linear Unit	Art. No.		Synchronising Set	Art. No.	Accessories	
Linear Unit KRF 8 80x40 ZR, left-hand input shaft	0.0.641.21	26	Synchronising Set KRF 8 80 ZR	0.0.648.58	0.0.609.83	95
Linear Unit KRF 8 80x40 ZR, right-hand input shaft	0.0.648.66					
Linear Unit KRF 8 80x40 ZR, synchronous drive	0.0.648.69					

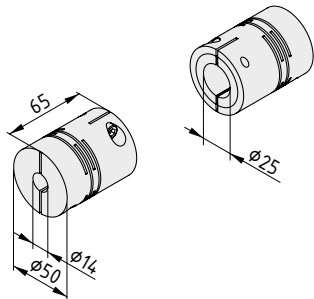

### Synchronising Set KRF 8 80 ZR

2 equaliser couplings D50, St, stainless  
 Tightening torque, clamping hub screw: 14.5 Nm  
 m = 1.2 kg

1 set	0.0.648.58
-------	------------



## Synchronising Sets LRE

- Configured for Linear Units LRE
- Several shaft diameters available

Synchronising Sets from item can be used to operate two Linear Units in parallel with just one motor. They comprise shaft couplings that are tailored to the relevant Linear Unit and designed to compensate for slight misalignments and withstand the stated torque over long-term use. These couplings are pre-prepared to accommodate a synchronising shaft. Besides featuring a compact design, expanding hub couplings are also easy to use. The friction-based connection is created by tightening the central screw with the specified tightening torque. An integrated pull-off thread makes them easy to dismantle. First, the central screw is removed, then a longer screw is driven into the same position to effortlessly relieve tension in the coupling.

Please note that the maximum length of the synchronising shaft varies depending on its operating speed.



### Note:

Use the diagrams in the "Technical data" section to coordinate the speed and length of your synchronising shaft.

Linear Unit	Art. No.		Synchronising Set	Art. No.	Accessories	
Linear Unit LRE 5 D6 60x20 ZU 40 R10	0.0.666.89	28	Synchronising Set D30/D12	0.0.662.51	0.0.664.14	97
Linear Unit LRE 8 D10 80x40 ZU 40 R25	0.0.662.70	31	Synchronising Set D40/D15	0.0.662.50	0.0.609.86	97
Linear Unit LRE 8 D10 80x80 ZU 40 R25	0.0.663.32	33				
Linear Unit LRE 8 D14 80x40 ZU 40 R25	0.0.662.91	34				
Linear Unit LRE 8 D14 80x80 ZU 40 R25	0.0.663.25	36				
Linear Unit LRE 8 D14 120x80 ZU 40 R25	0.0.663.34	38				
Linear Unit LRE 8 D14 80x40 KU 80	0.0.664.54	55	Synchronising Set D55/D34	0.0.666.60	0.0.609.83	97
Linear Unit LRE 8 D14 80x40 ZU 80 R25	0.0.663.12	35				
Linear Unit LRE 8 D14 80x80 ZU 80 R25	0.0.663.26	37				
Linear Unit LRE 8 D14 120x80 ZU 80 R25	0.0.663.35	38				
Linear Unit LRE 8 D25 120x80 ZU 80 R25	0.0.663.36	41				
Linear Unit LRE 8 D25 200x80 ZU 80 R25	0.0.666.53	43	Synchronising Set D80/D34	0.0.666.61	0.0.463.56	97
Linear Unit LRE 8 D25 120x80 ZU 80 R50	0.0.666.65	42				
Linear Unit LRE 8 D25 200x80 ZU 80 R50	0.0.666.66	44				

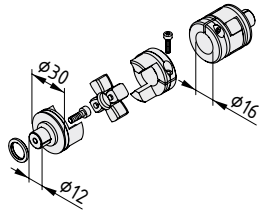

#### Synchronising Set D30/D12

2 Coupling Halves D30/D16, Al  
 2 expanding hub coupling halves D30/D12, St and Al  
 2 Coupling Inserts D30, PU, blue  
 2 Spacer Washers D12  
 Tightening torque, expanding hub screw: 2.8 Nm  
 Tightening torque, clamping hub screw: 2 Nm  
 m = 93.0 g

1 set 0.0.662.51

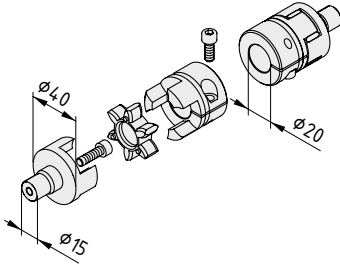

#### Synchronising Set D40/D15

2 Coupling Halves D40/D20, Al  
 2 expanding hub coupling halves D40/D15, St and Al  
 2 Coupling Inserts D40, PU, green  
 Tightening torque, expanding hub screw: 9.6 Nm  
 Tightening torque, clamping hub screw: 9.6 Nm  
 m = 198.0 g

1 set 0.0.662.50

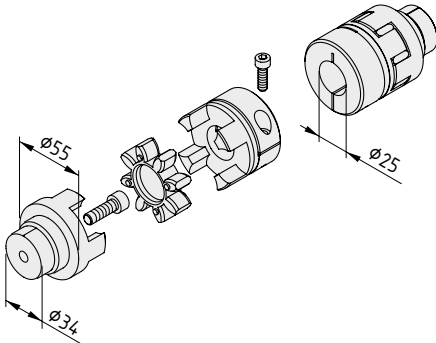

#### Synchronising Set D55/D34

2 Coupling Halves D55/D25, Al  
 2 expanding hub coupling half D55/D34, St and Al  
 2 Coupling Inserts D55, PU, green  
 Tightening torque, expanding hub screw: 23 Nm  
 Tightening torque, clamping hub screw: 9.6 Nm  
 m = 756.0 g

1 set 0.0.666.60

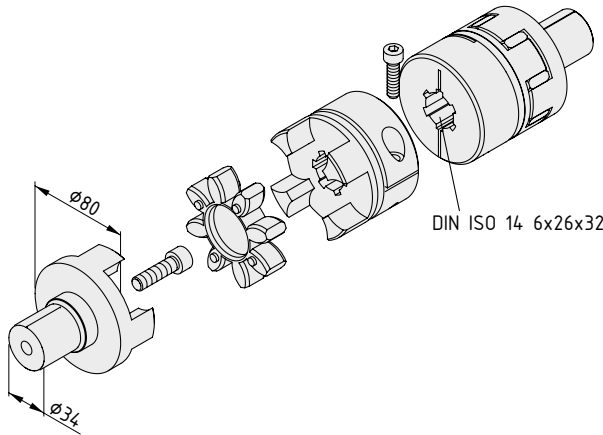

#### Synchronising Set D80/D34

2 Coupling Halves D80/VK32, Al  
 2 expanding hub coupling halves D80/D34, St and Al  
 2 Coupling Inserts D80, PU, red  
 Tightening torque, expanding hub screw: 49 Nm  
 Tightening torque, clamping hub screw: 23 Nm  
 m = 2.1 kg

1 set 0.0.666.61



## Tubes for Synchronising Sets

- Torsion-resistant steel tubes
- Compatible with item Synchronising Sets

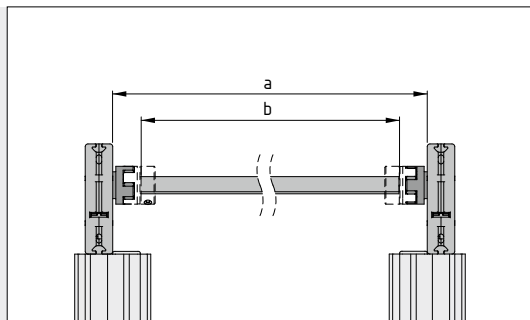

A suitable Tube St (sawn to length) turns the Synchronising Set into a complete synchroniser shaft.

Information for synchroniser shaft speed 168

Synchronising Set	Tube D16x1.5 St	Tube D20x3 St	Tube D25x3 St	a
D30/D12	a - 42.5 mm	—	—	Distance between Reverse Units
D40/D15	—	a - 50 mm	—	
D55/D34	—	—	a - 82 mm	
GSF 8 40 R10	a - 40.5 mm	—	—	
KLE 6 60x60	—	a - 65 mm	—	
KLE 8 80x80	—	—	a - 70 mm	
KRF 8 80 ZR	—	—	a - 100 mm	

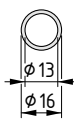

### Tube D16x1.5 St

St

m [kg/m]	I <sub>x</sub> [cm <sup>4</sup> ]	I <sub>y</sub> [cm <sup>4</sup> ]	I <sub>t</sub> [cm <sup>4</sup> ]	W <sub>x</sub> [cm <sup>3</sup> ]	W <sub>y</sub> [cm <sup>3</sup> ]
0.54	0.18	0.18	0.36	0.23	0.23

stainless, cut-off max. 2990 mm

0.0.664.14

stainless, 1 pce., length 2990 mm

0.0.662.92

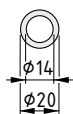

### Tube D20x3 St

St

m [kg/m]	I <sub>x</sub> [cm <sup>4</sup> ]	I <sub>y</sub> [cm <sup>4</sup> ]	I <sub>t</sub> [cm <sup>4</sup> ]	W <sub>x</sub> [cm <sup>3</sup> ]	W <sub>y</sub> [cm <sup>3</sup> ]
1.26	0.60	0.60	1.18	0.60	0.60

bright zinc-plated, cut-off max. 6000 mm

0.0.609.86

bright zinc-plated, 1 pce., length 6000 mm

0.0.609.85

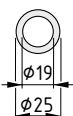

### Tube D25x3 St

St

m [kg/m]	I <sub>x</sub> [cm <sup>4</sup> ]	I <sub>y</sub> [cm <sup>4</sup> ]	I <sub>t</sub> [cm <sup>4</sup> ]	W <sub>x</sub> [cm <sup>3</sup> ]	W <sub>y</sub> [cm <sup>3</sup> ]
1.63	1.28	1.28	2.53	1.02	1.02

bright zinc-plated, cut-off max. 6000 mm

0.0.609.83

bright zinc-plated, 1 pce., length 6000 mm

0.0.609.82

## Synchronising Shaft Profile

- For easily constructing synchroniser shafts between drive elements
- Connection made via Multi-Spline Shafts
- Increased torsional rigidity

The Synchronising Shaft Profiles are used to build synchroniser shafts using sections of Multi-Spline Shaft VK32. Shafts and Synchronising Shaft Profiles are mechanically interlocked. A Synchroniser Shaft Equaliser Coupling can be used to adjust the torsion angle.

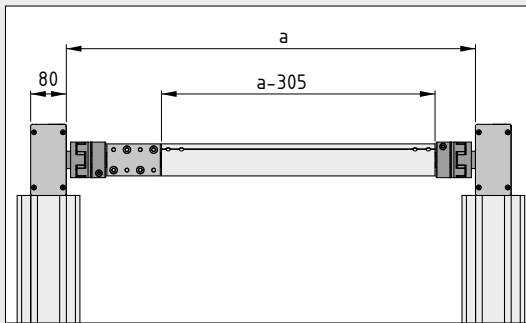

a = distance between drive Reverse Units

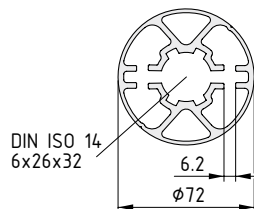

### Synchronising Shaft Profile VK32

Al, anodized

A [cm <sup>2</sup> ]	m [kg/m]	I <sub>x</sub> [cm <sup>4</sup> ]	I <sub>y</sub> [cm <sup>4</sup> ]	I <sub>z</sub> [cm <sup>4</sup> ]	
11.62	3.13	47.42	45.09	65.95	
natural, cut-off max. 3000 mm					0.0.463.56
natural, 1 pce., length 3000 mm					0.0.454.05

### Clamping Set for Synchronising Shaft Profile VK32

8 standard connecting plates 6, St, bright zinc-plated  
 4 T-Slot Nuts 8 St 2xM6-60, bright zinc-plated  
 8 screws M6x25, St, bright zinc-plated  
 m = 196.0 g

1 set	0.0.463.30
-------	------------

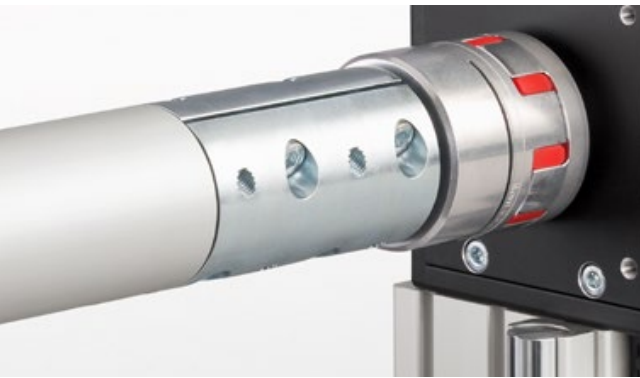

## Accessories for Synchronising Shaft Profile

- Compatible with item Synchronising Shaft Profile VK32
- Connecting Shaft for drive
- Simple adjustment thanks to Equaliser Coupling

Connecting Shafts are used to provide a torsionally rigid connection between the mechanical drive elements and the corresponding Coupling Half. The Connecting Shafts are inserted into the drive elements until they come up against the stop of the Snap Ring. The clampable Coupling Half is slipped onto the free end of the shaft and clamped axially such that the length of the coupling matches the length of the Coupling Housing, and the Coupling Inserts are not under any axial load.

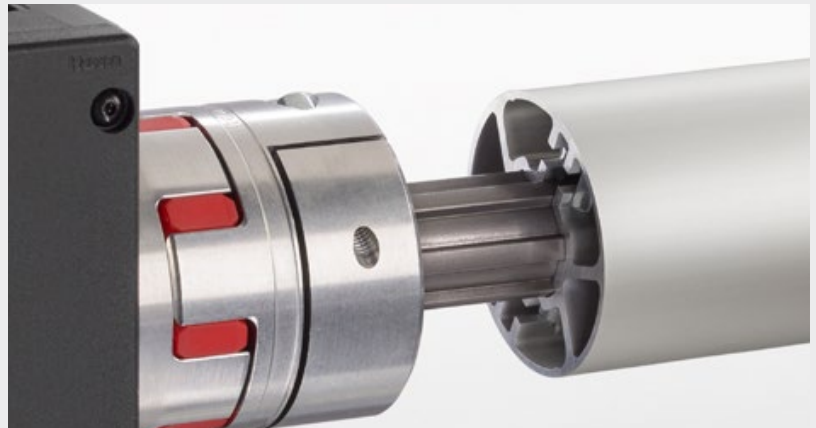

When using synchronising shafts to transfer torque, it may be necessary to ensure the connected drives can be adjusted during installation.

The Synchroniser Shaft Equaliser Coupling can be used to divide a synchronising shaft in two and then create a friction-based connection between the two shaft sections.

The snap rings W32 should be used to secure the synchronising shaft axially between the drive elements.

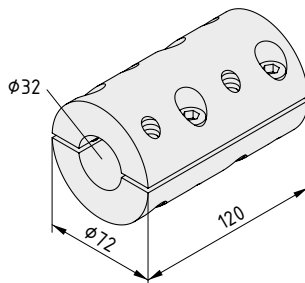
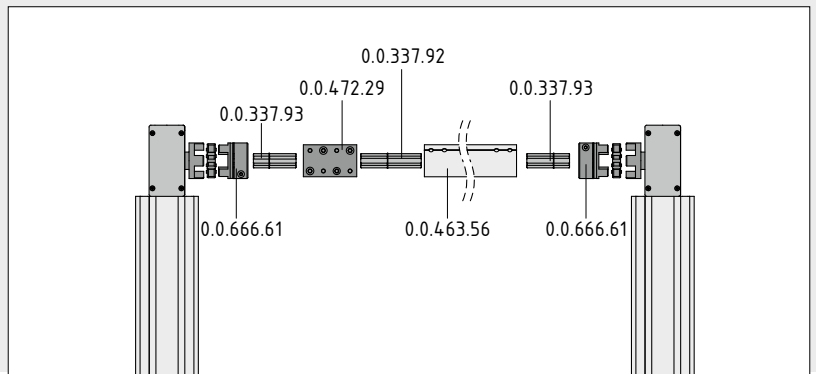

### Synchroniser Shaft Equaliser Coupling VK32

- 2 half shells, St, bright zinc-plated
- 8 Hexagon Socket Head Cap Screws DIN 912-M10x30, St, bright zinc-plated and waxed
- 8 screws M6x25, St, bright zinc-plated
- m = 2.8 kg

1 set

0.0.472.29

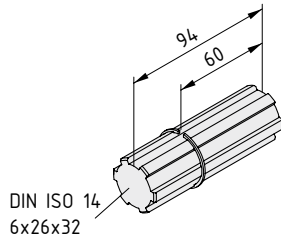

#### Connecting Shaft VK32 R25

Multi-Spline Shaft similar to DIN ISO 14 6x26x32, St, C 45 k  
Snap Ring W32  
m = 470.0 g

1 pce. 0.0.337.93

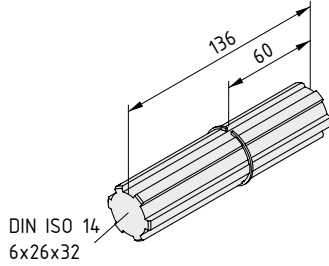

#### Connecting Shaft VK32 R50

Multi-Spline Shaft similar to DIN ISO 14 6x26x32, St, C 45 k  
Snap Ring W32  
m = 680.0 g

1 pce. 0.0.337.92





## Synchroniser Shaft Cover Sets

- For fixing in place protective Conduit Profiles
- Configured for Linear Units that can be synchronised

For safety reasons, Synchroniser Shaft Cover Set GSF 8 40 R10 should be used to enclose the synchroniser shaft between two Linear Units GSF 8 40 so that material cannot become entangled in the rotating tube.

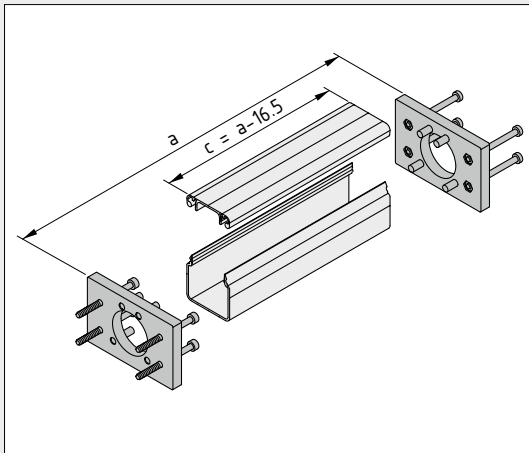

The adapter plates included in the Synchroniser Shaft Cover Set secure the conduit elements between the two timing-belt drives of Linear Units GSF 8 40 R10. Calculating the length:

a = Distance between Linear Units

c = Length of conduit elements

Use this cable conduit:

Conduit Profile U 40x40 E (7.0.001.44)

Lid Profile D40 E (7.0.001.46)

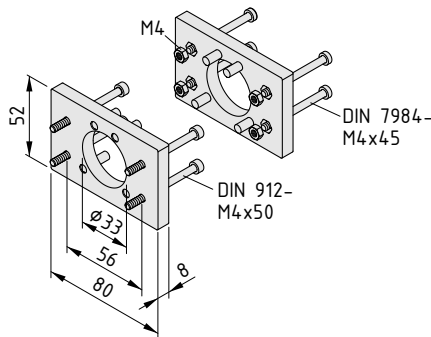

### Synchroniser Shaft Cover Set GSF 8 40 R10

- 2 Synchroniser Adapter Plates GSF 8 40, Al, natural
- 4 Hexagon Socket Head Cap Screws DIN 7984-M4x45, St, bright zinc-plated
- 4 Hexagon Socket Head Cap Screws DIN 912-M4x50, St, bright zinc-plated
- 4 hexagon nuts DIN 934-M4-5, St, bright zinc-plated
- 8 taper grooved dowel pins ISO 8745 5x18, St
- m = 202.0 g

1 set

0.0.662.54

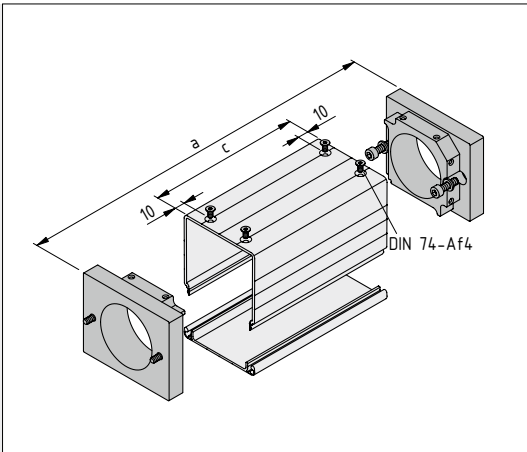

The conduit elements are fixed in place between the two timing-belt drives of Linear Units KLE using the adapter plates in the Synchroniser Shaft Cover Set.

Linear Unit KLE 6 60x60:  
 Conduit Profile U 60x60 E (7.0.002.91)  
 Lid Profile D60 E (7.0.002.87)  
 $c = a - 24.5$  mm (adapter plate thickness = 12 mm)

Linear Unit KLE 8 80x80:  
 Conduit Profile U 80x80 E (7.0.002.74)  
 Lid Profile D80 E (7.0.002.73)  
 $c = a - 32.5$  mm (adapter plate thickness = 16 mm)

$a$  = Distance between Linear Units  
 $c$  = Length of conduit elements

The Conduit Profiles must be provided with DIN 74-Af4 countersinks for their fixings.

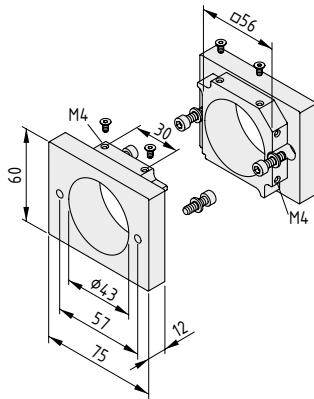

#### Synchroniser Shaft Cover Set KLE 6 60x60

2 Synchroniser Adapter Plates KLE 6 60x60, Al  
 4 Hexagon Socket Head Cap Screws DIN 912-M5x16,  
 St, bright zinc-plated  
 4 Washers DIN 433 5.3, St, bright zinc-plated  
 4 Countersunk Screws DIN 7991-M4x8, St, bright zinc-plated  
 $m = 300.0$  g

1 set

0.0.612.46

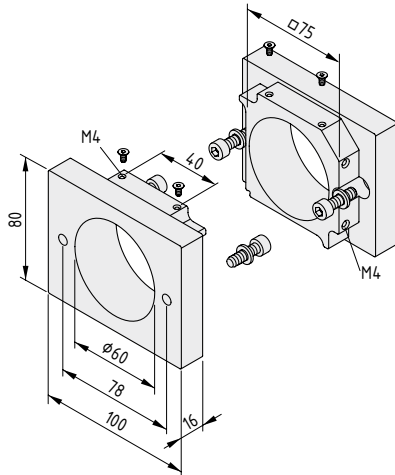

#### Synchroniser Shaft Cover Set KLE 8 80x80

2 Synchroniser Adapter Plates KLE 8 80x80, Al  
 4 Hexagon Socket Head Cap Screws DIN 912-M6x20,  
 St, bright zinc-plated  
 4 Washers DIN 433 6.4, St, bright zinc-plated  
 4 Countersunk Screws DIN 7991-M4x8, St, bright zinc-plated  
 $m = 625.0$  g

1 set

0.0.612.45

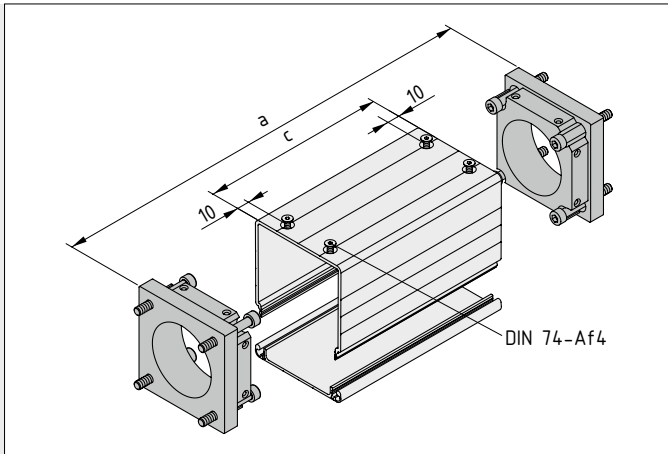

The conduit elements are fixed in place between the two drive units of Linear Units KRF using the adapter plates in the Synchroniser Shaft Cover Set.

a = Distance between Linear Units

c = Length of conduit elements

Conduit Profile U 80x80 E (Art. No. 7.0.002.74)

Lid Profile D80 E (Art. No. 7.0.002.73)

c = a - 24.5 mm (adapter plate thickness = 12 mm)

The Conduit Profiles must be provided with DIN 74-Af4 countersinks for their fixings.

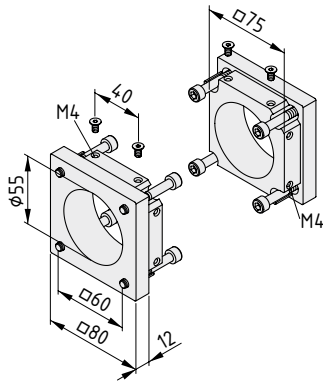

### Synchroniser Shaft Cover Set KRF 8 80 ZR

2 synchroniser adapter plates KRF 8 80x80, Al, natural

4 Hexagon Socket Head Cap Screws DIN 912-M6x45, St, bright zinc-plated

4 Hexagon Socket Head Cap Screws DIN 912-M6x60, St, bright zinc-plated

4 Countersunk Screws DIN 7991-M4x8, St, bright zinc-plated

m = 540.0 g

1 set

0.0.648.59

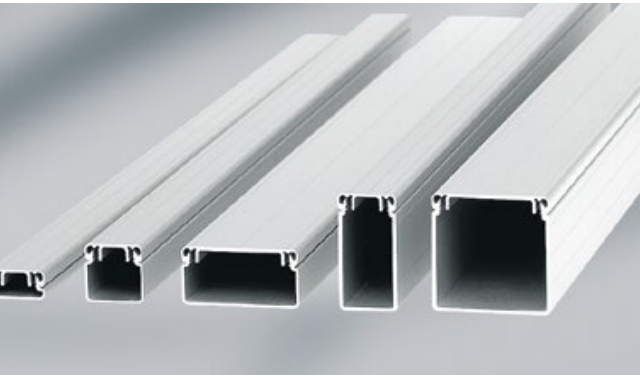

## Conduit and Lid Profiles

- Shaft covered for added safety
- Prevents soiling

Conduit and Lid Profiles encompass the synchroniser shaft on all sides to prevent injuries that can be caused by exposed moving parts. The appropriate Synchroniser Shaft Cover Set should be used to fasten the cover to both Linear Units.

Linear Unit	Art. No.		Synchroniser Shaft Cover Set	Art. No.		Conduit Profile	Art. No.		Lid Profile	Art. No.	
GSF 8 40 R10	0.0.655.98	20	Synchroniser Shaft Cover Set GSF 8 40 R10	0.0.662.54	102	Conduit Profile U 40x40 E	7.0.001.44	105	Lid Profile D40 E	7.0.001.46	106
KLE 6 60x60 LR	0.0.605.07	23	Synchroniser Shaft Cover Set KLE 6 60x60	0.0.612.46	103	Conduit Profile U 60x60 E	7.0.002.91	105	Lid Profile D60 E	7.0.002.87	106
KLE 8 80x80 LR	0.0.605.02	24	Synchroniser Shaft Cover Set KLE 8 80x80	0.0.612.45	103	Conduit Profile U 80x80 E	7.0.002.74	106	Lid Profile D80 E	7.0.002.73	106
KRF 8 80x40 ZR, drive on right	0.0.648.66	26	Synchroniser Shaft Cover Set KRF 8 80 ZR	0.0.648.59	104						
KRF 8 80x40 ZR, drive on left	0.0.641.21	26									
KRF 8 80x40 ZR, synchronous drive	0.0.648.69	27									

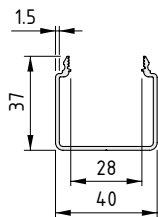

### Conduit Profile U 40x40 E

Al, anodized

A [cm<sup>2</sup>]    m [kg/m]

1.70    0.45

natural, cut-off max. 3000 mm

7.0.001.44

natural, 1 pce., length 3000 mm

0.0.452.20

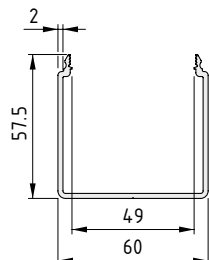

### Conduit Profile U 60x60 E

Al, anodized

A [cm<sup>2</sup>]    m [kg/m]

3.38    0.91

natural, cut-off max. 3000 mm

7.0.002.91

natural, 1 pce., length 3000 mm

0.0.451.45

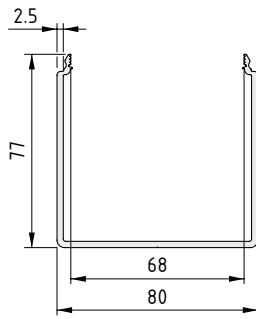

**Conduit Profile U 80x80 E**

Al, anodized

A [cm <sup>2</sup> ]	m [kg/m]
----------------------	----------

5.61	1.52
------	------

natural, cut-off max. 3000 mm	7.0.002.74
-------------------------------	------------

natural, 1 pce., length 3000 mm	7.0.002.78
---------------------------------	------------

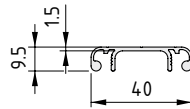

**Lid Profile D40 E**

Al, anodized

A [cm <sup>2</sup> ]	m [kg/m]
----------------------	----------

1.13	0.30
------	------

natural, cut-off max. 3000 mm	7.0.001.46
-------------------------------	------------

natural, 1 pce., length 3000 mm	0.0.452.09
---------------------------------	------------

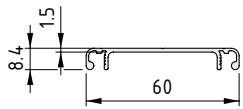

**Lid Profile D60 E**

Al, anodized

A [cm <sup>2</sup> ]	m [kg/m]
----------------------	----------

1.50	0.41
------	------

natural, cut-off max. 3000 mm	7.0.002.87
-------------------------------	------------

natural, 1 pce., length 3000 mm	0.0.451.43
---------------------------------	------------

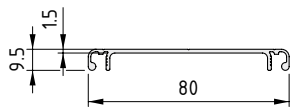

**Lid Profile D80 E**

Al, anodized

A [cm <sup>2</sup> ]	m [kg/m]
----------------------	----------

2.12	0.57
------	------

natural, cut-off max. 3000 mm	7.0.002.73
-------------------------------	------------

natural, 1 pce., length 3000 mm	7.0.002.77
---------------------------------	------------



## Gearboxes

Gearboxes connect together the Linear Unit, Drive Set and Motor and ensure users can achieve the correct ratio of input speed, torque and precise carriage positioning for any application. item Gearboxes also help make optimum use of the installation space available. Motors can be fitted in line with the Drive Set or offset at a 90° angle from it.

To ensure reliability and a long service life, item uses only high-quality planetary Gearboxes that distribute forces to the gears with low backlash. They are also compact, very quiet and have a maintenance-free design.



**Note:**  
You can find a table comparing all the item Gearboxes starting on Page 174.

## Products in this section



### Axial planetary Gearboxes

- Linear, axial connection for motors
- Suitable for high speeds and torques

109



### Bevel planetary Gearboxes

- Right-angled connection for motors
- Suitable for high speeds and torques

113





## Gearboxes AP

- Axial connection for motors
- Suitable for very high input speeds
- Highly efficient with low backlash

Gearboxes AP connect a Motor with a Drive Set along a shared axis. The compact planetary gearboxes are available in various gear ratios and in three connection dimensions. They exhibit a high degree of efficiency and are suitable for very high input speeds up to 18000 rpm.

The Gearboxes run quietly and have a long service life. All variants are maintenance free and do not require additional lubrication.

**NB:** The modular item Automation System can be used to configure solutions using preassembled components. Please ensure that the connection dimensions for the selected Motor, Gearbox and Drive Set are identical.

## Gearbox AP 40

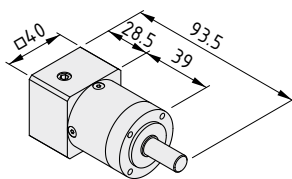
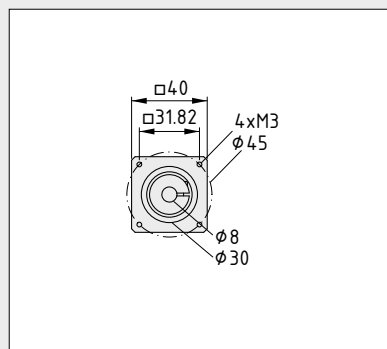
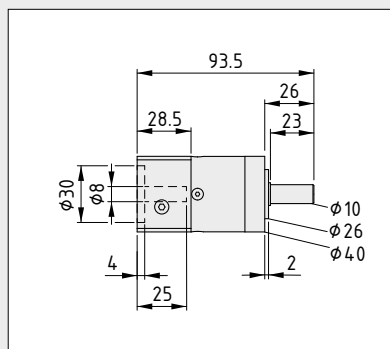
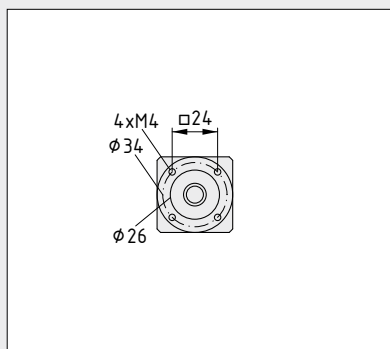
**Gearbox AP 40-3**

Gear ratio	$i = 3$
Efficiency at full load	0.98
Rated output torque	11 Nm
Max. mechanical input speed	18000 rpm
Mass moment of inertia	0.027 kg cm <sup>2</sup>
Standard backlash	< 15 arcmin
Tightening torque, clamping hub screw	2 Nm

white aluminium, similar to RAL 9006, 1 pce.

**0.0.666.05****Gearbox AP 40-5**

Gear ratio	$i = 5$
Efficiency at full load	0.98
Rated output torque	14 Nm
Max. mechanical input speed	18000 rpm
Mass moment of inertia	0.019 kg cm <sup>2</sup>
Standard backlash	< 15 arcmin
Tightening torque, clamping hub screw	2 Nm

white aluminium, similar to RAL 9006, 1 pce.

**0.0.666.06****Gearbox AP 40-7**

Gear ratio	$i = 7$
Efficiency at full load	0.97
Rated output torque	8.5 Nm
Max. mechanical input speed	18000 rpm
Mass moment of inertia	0.015 kg cm <sup>2</sup>
Standard backlash	< 15 arcmin
Tightening torque, clamping hub screw	2 Nm

white aluminium, similar to RAL 9006, 1 pce.

**0.0.666.07**

## Gearbox AP 60

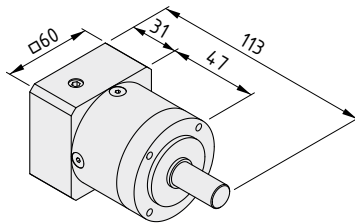
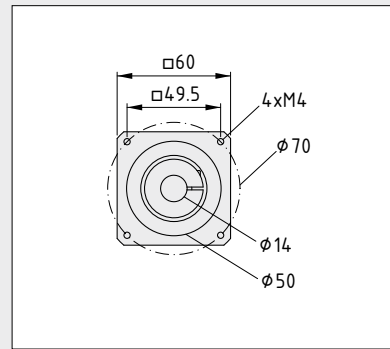
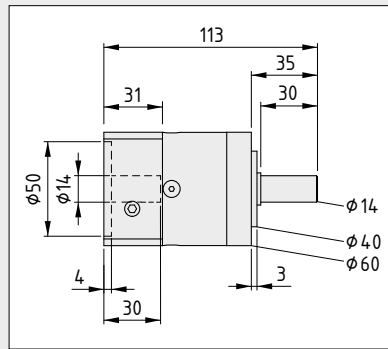
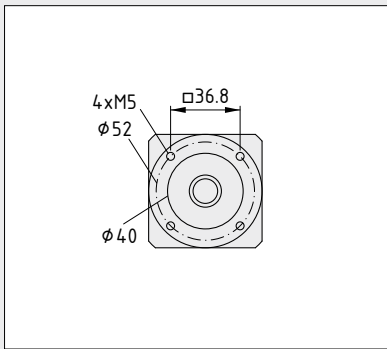

### Gearbox AP 60-3

Gear ratio	$i = 3$
Efficiency at full load	0.98
Rated output torque	28 Nm
Max. mechanical input speed	13000 rpm
Mass moment of inertia	0.149 kg cm <sup>2</sup>
Standard backlash	< 10 arcmin
Tightening torque, clamping hub screw	4.5 Nm

white aluminium, similar to RAL 9006, 1 pce.

0.0.666.11

### Gearbox AP 60-5

Gear ratio	$i = 5$
Efficiency at full load	0.98
Rated output torque	40 Nm
Max. mechanical input speed	13000 rpm
Mass moment of inertia	0.1 kg cm <sup>2</sup>
Standard backlash	< 10 arcmin
Tightening torque, clamping hub screw	4.5 Nm

white aluminium, similar to RAL 9006, 1 pce.

0.0.666.12

### Gearbox AP 60-7

Gear ratio	$i = 7$
Efficiency at full load	0.97
Rated output torque	25 Nm
Max. mechanical input speed	13000 rpm
Mass moment of inertia	0.09 kg cm <sup>2</sup>
Standard backlash	< 10 arcmin
Tightening torque, clamping hub screw	4.5 Nm

white aluminium, similar to RAL 9006, 1 pce.

0.0.666.13

### Gearbox AP 60-16

Gear ratio	$i = 16$
Efficiency at full load	0.96
Rated output torque	44 Nm
Max. mechanical input speed	13000 rpm
Mass moment of inertia	0.106 kg cm <sup>2</sup>
Standard backlash	< 12 arcmin
Tightening torque, clamping hub screw	4.5 Nm

white aluminium, similar to RAL 9006, 1 pce.

0.0.698.04

## Gearbox AP 80

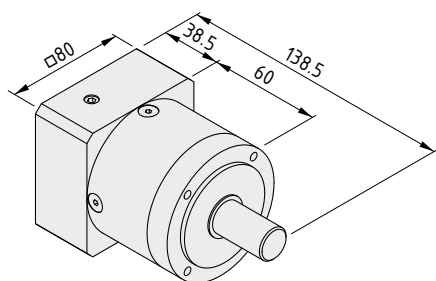
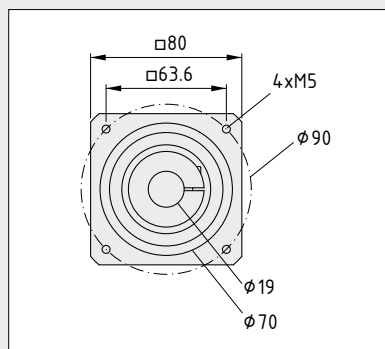
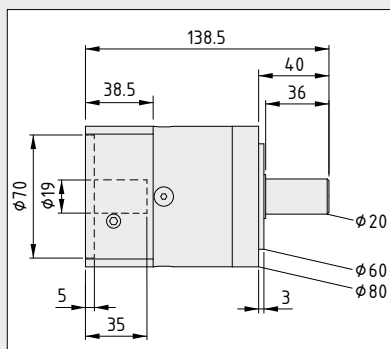
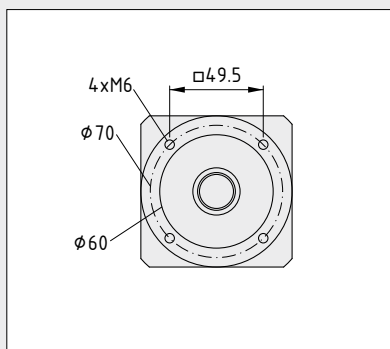
**Gearbox AP 80-3**

Gear ratio	$i = 3$
Efficiency at full load	0.98
Rated output torque	85 Nm
Max. mechanical input speed	7000 rpm
Mass moment of inertia	0.654 kg cm <sup>2</sup>
Standard backlash	< 7 arcmin
Tightening torque, clamping hub screw	9.5 Nm

white aluminium, similar to RAL 9006, 1 pce.

0.0.666.17

**Gearbox AP 80-5**

Gear ratio	$i = 5$
Efficiency at full load	0.98
Rated output torque	110 Nm
Max. mechanical input speed	7000 rpm
Mass moment of inertia	0.423 kg cm <sup>2</sup>
Standard backlash	< 7 arcmin
Tightening torque, clamping hub screw	9.5 Nm

white aluminium, similar to RAL 9006, 1 pce.

0.0.666.18

**Gearbox AP 80-7**

Gear ratio	$i = 7$
Efficiency at full load	0.97
Rated output torque	65 Nm
Max. mechanical input speed	7000 rpm
Mass moment of inertia	0.379 kg cm <sup>2</sup>
Standard backlash	< 7 arcmin
Tightening torque, clamping hub screw	9.5 Nm

white aluminium, similar to RAL 9006, 1 pce.

0.0.666.19



## Gearboxes WP

- Right-angled connection for motors
- Suitable for very high input speeds
- Highly efficient with low backlash

Gearboxes WP connect a Motor with a Drive Set at a 90° angle. The compact planetary Gearboxes are available in various gear ratios and in three connection sizes. They exhibit a high degree of efficiency and are suitable for very high input speeds up to 18000 rpm.

The Gearboxes run quietly and have a long service life. All variants are maintenance-free and do not require additional lubrication.

**Note:** The modular item Automation System can be used to configure solutions using preassembled components. Please ensure that the connection dimensions for the selected Motor, Gearbox and Drive Set are identical.

## Gearbox WP 40

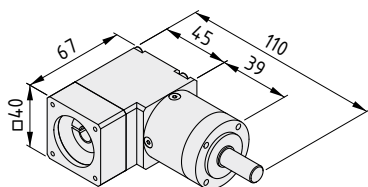
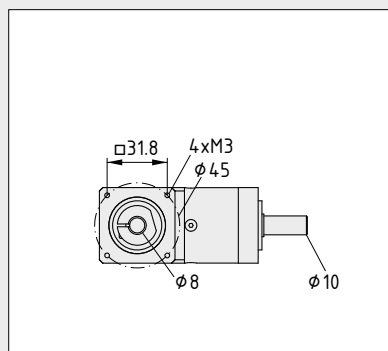
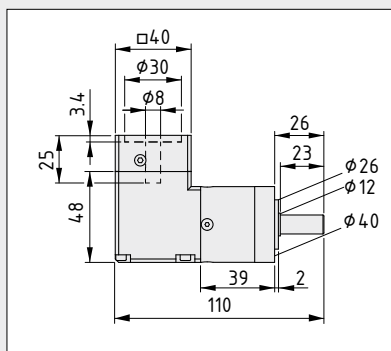
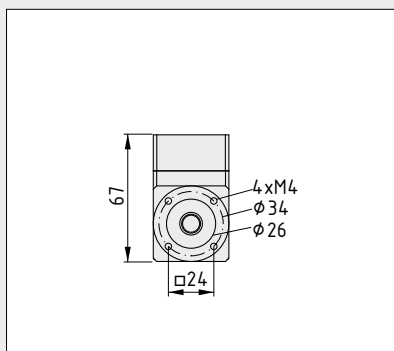
**Gearbox WP 40-3**

Gear ratio	$i = 3$
Efficiency at full load	0.94
Rated output torque	3.96 Nm
Max. mechanical input speed	18000 rpm
Mass moment of inertia	0.049 kg cm <sup>2</sup>
Standard backlash	< 21 arcmin
Tightening torque, clamping hub screw	2 Nm

white aluminium, similar to RAL 9006, 1 pce.

0.0.666.08

**Gearbox WP 40-5**

Gear ratio	$i = 5$
Efficiency at full load	0.94
Rated output torque	6.6 Nm
Max. mechanical input speed	18000 rpm
Mass moment of inertia	0.035 kg cm <sup>2</sup>
Standard backlash	< 21 arcmin
Tightening torque, clamping hub screw	2 Nm

white aluminium, similar to RAL 9006, 1 pce.

0.0.666.09

**Gearbox WP 40-7**

Gear ratio	$i = 7$
Efficiency at full load	0.94
Rated output torque	7.48 Nm
Max. mechanical input speed	18000 rpm
Mass moment of inertia	0.033 kg cm <sup>2</sup>
Standard backlash	< 21 arcmin
Tightening torque, clamping hub screw	2 Nm

white aluminium, similar to RAL 9006, 1 pce.

0.0.666.10

## Gearbox WP 60

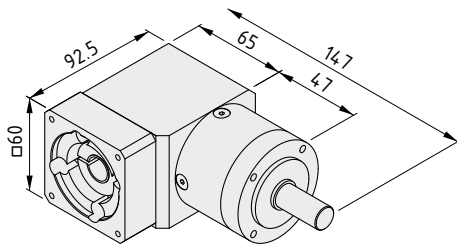
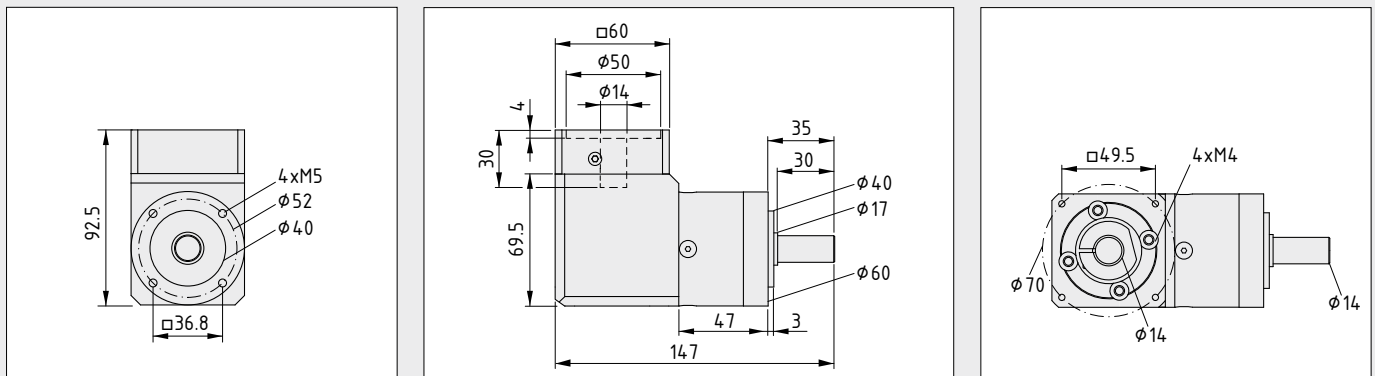

### Gearbox WP 60-3

Gear ratio	i = 3
Efficiency at full load	0.95
Rated output torque	12.32 Nm
Max. mechanical input speed	13000 rpm
Mass moment of inertia	0.394 kg cm <sup>2</sup>
Standard backlash	< 16 arcmin
Tightening torque, clamping hub screw	4.5 Nm

white aluminium, similar to RAL 9006, 1 pce.

0.0.666.14

### Gearbox WP 60-5

Gear ratio	i = 5
Efficiency at full load	0.95
Rated output torque	21.12 Nm
Max. mechanical input speed	13000 rpm
Mass moment of inertia	0.257 kg cm <sup>2</sup>
Standard backlash	< 16 arcmin
Tightening torque, clamping hub screw	4.5 Nm

white aluminium, similar to RAL 9006, 1 pce.

0.0.666.15

### Gearbox WP 60-7

Gear ratio	i = 7
Efficiency at full load	0.94
Rated output torque	22 Nm
Max. mechanical input speed	13000 rpm
Mass moment of inertia	0.245 kg cm <sup>2</sup>
Standard backlash	< 16 arcmin
Tightening torque, clamping hub screw	4.5 Nm

white aluminium, similar to RAL 9006, 1 pce.

0.0.666.16

### Gearbox WP 60-16

Gear ratio	i = 16
Efficiency at full load	0.93
Rated output torque	38.72 Nm
Max. mechanical input speed	13000 rpm
Mass moment of inertia	0.27 kg cm <sup>2</sup>
Standard backlash	< 18 arcmin
Tightening torque, clamping hub screw	4.5 Nm

white aluminium, similar to RAL 9006, 1 pce.

0.0.698.05

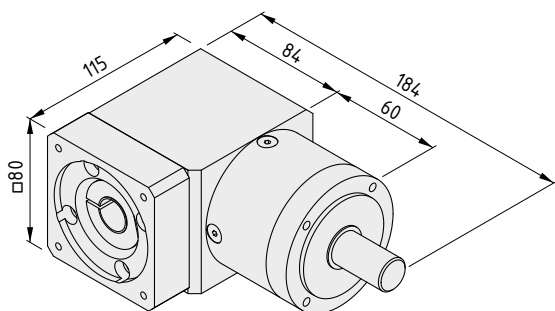
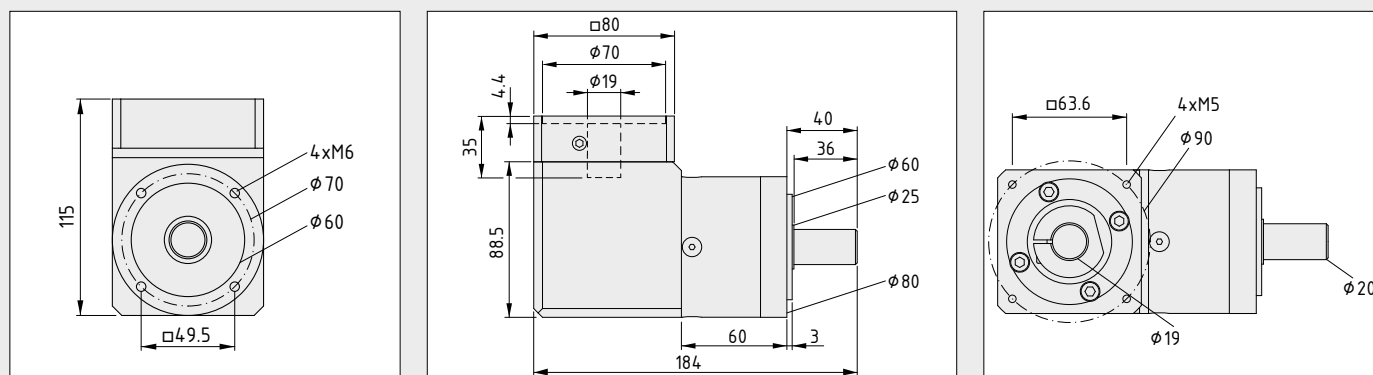

## Gearbox WP 80

**Gearbox WP 80-3**

Gear ratio	$i = 3$
Efficiency at full load	0.96
Rated output torque	35.2 Nm
Max. mechanical input speed	7000 rpm
Mass moment of inertia	1.409 kg cm <sup>2</sup>
Standard backlash	< 13 arcmin
Tightening torque, clamping hub screw	9.5 Nm

white aluminium, similar to RAL 9006, 1 pce.

0.0.666.20

**Gearbox WP 80-5**

Gear ratio	$i = 5$
Efficiency at full load	0.95
Rated output torque	58.96 Nm
Max. mechanical input speed	7000 rpm
Mass moment of inertia	1.017 kg cm <sup>2</sup>
Standard backlash	< 13 arcmin
Tightening torque, clamping hub screw	9.5 Nm

white aluminium, similar to RAL 9006, 1 pce.

0.0.666.21

**Gearbox WP 80-7**

Gear ratio	$i = 7$
Efficiency at full load	0.95
Rated output torque	57.2 Nm
Max. mechanical input speed	7000 rpm
Mass moment of inertia	0.948 kg cm <sup>2</sup>
Standard backlash	< 13 arcmin
Tightening torque, clamping hub screw	9.5 Nm

white aluminium, similar to RAL 9006, 1 pce.

0.0.666.22



## Motors

In automation, motors are more than just drive units. As well as determining the dynamics of the system, they also play a key role in terms of precision and controlling movement. The reliability and safety of the system as a whole also depend on the quality of the motor.

That is why item uses high-quality synchronous motors. These electric motors supply high torque even at low rotational speeds and complete their start-up with excellent precision, even under high loads. Controlled synchronous operation in all phases boosts precision. As a servomotor, the drive supplies information about the angle of its motor shaft, as well as rotational speed and acceleration, to the Controller.

item uses Motors with a digital absolute encoder or analogue resolver for position control purposes. These contactless encoders, combined with the Controllers from item, ensure the Linear Unit can be positioned precisely in any phase of the motion cycle – even in difficult environmental conditions.

The item servomotors are perfectly configured for use with the item Linear Units, Gearboxes and Controllers.



**Note:**

You can find a clear comparison of all the item Motors starting on Page 176.

## Products in this section



**Motors SE 40**

- Very high nominal speed
- With resolver or absolute encoder

120



**Motors SE 60**

- High speed and high torque
- With resolver or absolute encoder

122



**Motors SE 80**

- Very high torque
- With absolute encoder

124



## Motors SE

- High nominal speed and durable design
- High load-to-size ratio and overload capacity
- With and without optional holding brake

Motors SE feature a high rated speed of up to 9000 rpm and are suitable for all applications that require precision and dynamic operation. Robust and precise encoders ensure the system exhibits reliable positioning characteristics over long term use.

Thanks to colour-coded plug-in connectors and item Power and Data Cables, the Motor can be connected to its Controller quickly and reliably. The servomotors are available with a holding brake (B in product name) and without a holding brake.

# Motors SE 40

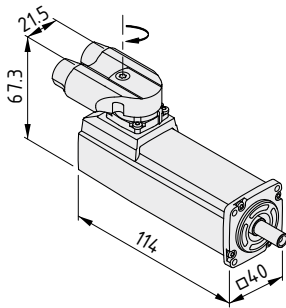
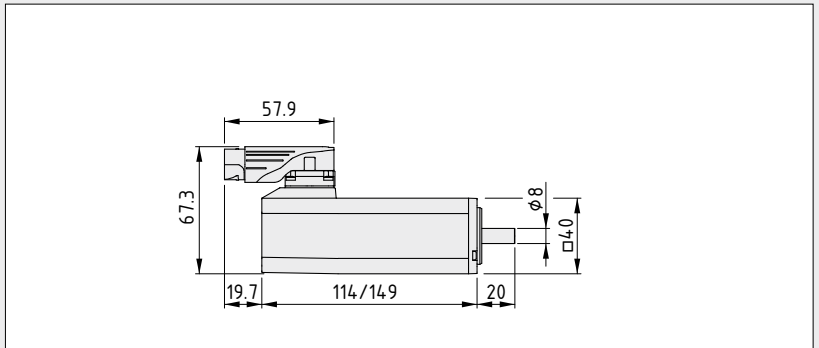
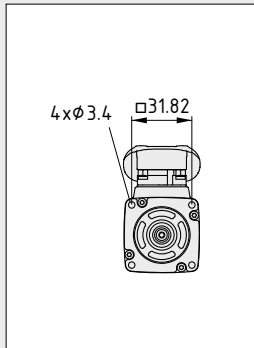
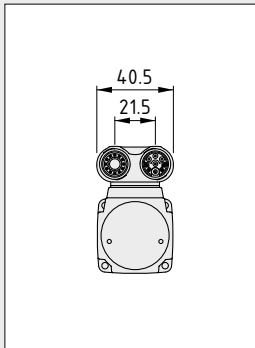

### Motor SE 40-035-3-90-R

Encoder systems	Resolver
Rated speed	9000 rpm
DC bus circuit voltage	320 V
Rated power	200 W
Rated torque	0.21 Nm
Stall torque	0.35 Nm
Peak torque	1.4 Nm
Holding brake	No

white aluminium, similar to RAL 9006, 1 pce.

0.0.666.03

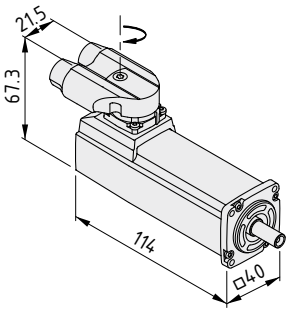

### Motor SE 40-035-3-90-AK

Encoder systems	Absolute encoder, capacitive
Rated speed	6000 rpm
DC bus circuit voltage	320 V
Rated power	200 W
Rated torque	0.21 Nm
Stall torque	0.35 Nm
Peak torque	1.4 Nm
Holding brake	No

white aluminium, similar to RAL 9006, 1 pce.

0.0.668.47

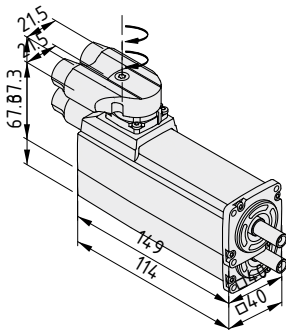

### Motor SE 40-035-3-90-R-B

Encoder systems	Resolver
Rated speed	9000 rpm
DC bus circuit voltage	320 V
Rated power	200 W
Rated torque	0.21 Nm
Stall torque	0.35 Nm
Peak torque	1.4 Nm
Holding brake	Yes
Static braking torque	0.4 Nm

white aluminium, similar to RAL 9006, 1 pce.

0.0.666.04

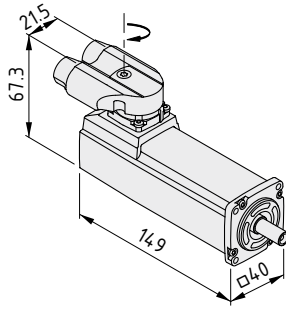

Motor SE 40-035-3-90-AK-B	
Encoder systems	Absolute encoder, capacitive
Rated speed	6000 rpm
DC bus circuit voltage	320 V
Rated power	200 W
Rated torque	0.21 Nm
Stall torque	0.35 Nm
Peak torque	1.4 Nm
Holding brake	Yes
Static braking torque	0.4 Nm
white aluminium, similar to RAL 9006, 1 pce.	
<b>0.0.688.48</b>	

## Motors SE 60

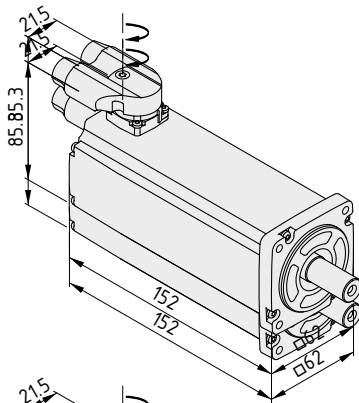
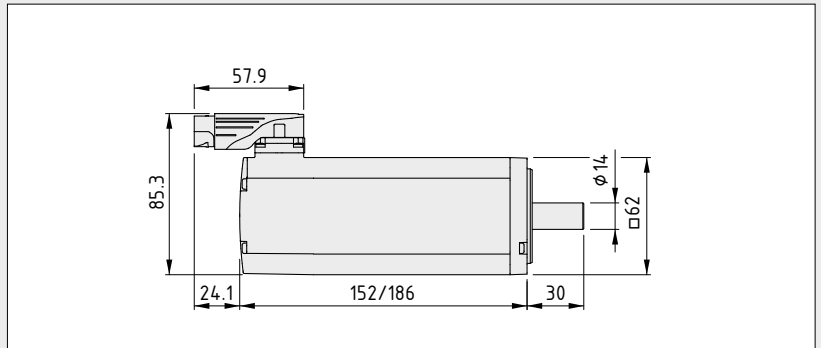
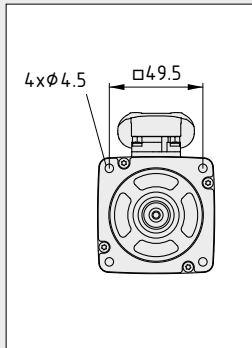
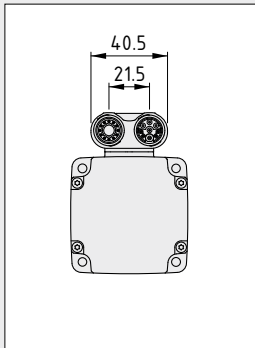

### Motor SE 60-150-3-60-AK

Encoder systems	Absolute encoder, capacitive
Rated speed	6000 rpm
DC bus circuit voltage	320 V
Rated power	550 W
Rated torque	0.9 Nm
Stall torque	1.5 Nm
Peak torque	6 Nm
Holding brake	No

white aluminium, similar to RAL 9006, 1 pce.

0.0.666.02

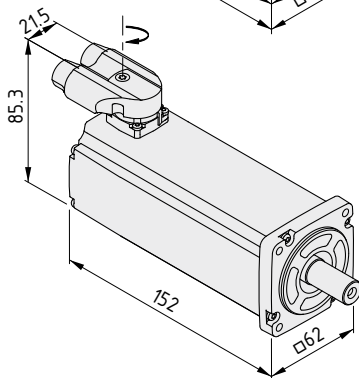

### Motor SE 60-150-3-60-AK

Encoder systems	Absolute encoder, capacitive
Rated speed	6000 rpm
DC bus circuit voltage	320 V
Rated power	550 W
Rated torque	0.9 Nm
Stall torque	1.5 Nm
Peak torque	6 Nm
Holding brake	No

white aluminium, similar to RAL 9006, 1 pce.

0.0.688.49

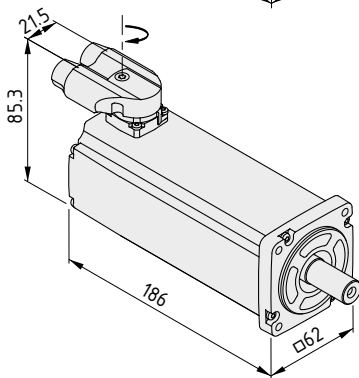

### Motor SE 60-150-3-60-R-B

Encoder systems	Resolver
Rated speed	6000 rpm
DC bus circuit voltage	320 V
Rated power	550 W
Rated torque	0.9 Nm
Stall torque	1.5 Nm
Peak torque	6 Nm
Holding brake	Yes
Static braking torque	2 Nm

white aluminium, similar to RAL 9006, 1 pce.

0.0.665.99

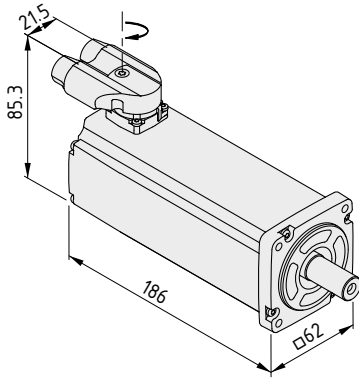

Motor SE 60-150-3-60-AK-B	
Encoder systems	Absolute encoder, capacitive
Rated speed	6000 rpm
DC bus circuit voltage	320 V
Rated power	550 W
Rated torque	0.9 Nm
Stall torque	1.5 Nm
Peak torque	6 Nm
Holding brake	Yes
Static braking torque	2 Nm
white aluminium, similar to RAL 9006, 1 pce.	
<b>0.0.688.50</b>	



# Motors SE 80

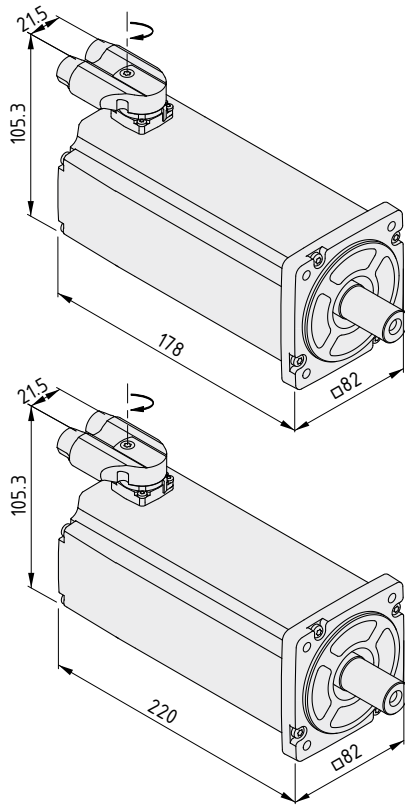
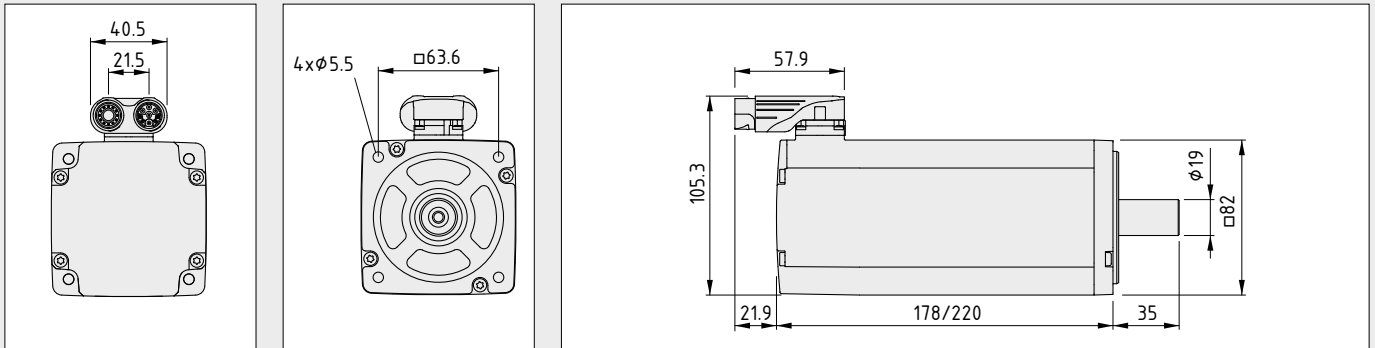

### Motor SE 80-350-5-55-AK

Encoder systems	Absolute encoder, capacitive
Rated speed	5500 rpm
DC bus circuit voltage	560 V
Rated power	1200 W
Rated torque	2.1 Nm
Stall torque	3.5 Nm
Peak torque	14 Nm
Holding brake	No

white aluminium, similar to RAL 9006, 1 pce.

0.0.688.51

### Motor SE 80-350-5-55-AK-B

Encoder systems	Absolute encoder, capacitive
Rated speed	5500 rpm
DC bus circuit voltage	560 V
Rated power	1200 W
Rated torque	2.1 Nm
Stall torque	3.5 Nm
Peak torque	14 Nm
Holding brake	Yes
Static braking torque	4.5 Nm

white aluminium, similar to RAL 9006, 1 pce.

0.0.688.52



## Controllers

item Controllers are the digital heart of the item linear motion units® and are perfectly configured for the Motors and Linear Units of the item Automation System.

These programmable servo controllers designed for industrial use combine several functions in one compact housing. They make it easy to construct a controlled automation solution and can be integrated into complex systems with ease.

These high-performance item Controllers are very easy to connect and operate. Together with the intuitive commissioning software item MotionSoft®, the intelligent controllers measure the Linear Unit independently. The Controller initiates an automatic test run to configure the parameters of the entire system

in its actual installation scenario and calculates the optimum controller settings for the drive system used.

Working with one overarching PLC doesn't pose any problems either. item Controllers support all standard fieldbus protocols and have numerous interfaces for processing signals. The BL series has all standard interfaces integrated as standard while the C series can be configured as required using slots and is therefore equipped to deal with future standards, too.

Single and three-phase models in various power stages are available to suit the relevant power supply and requirements of the Motor.



### Note:

You can find a detailed table comparing all the item Controllers starting on Page 178.

## Products in this section



### Controller BL 1

- Highly integrated Controller with extensive standard configuration
- For single-phase operation with 100 V to 230 V

127



### C 1 Controllers

- Expandible modular Controllers for item Motors
- For single-phase operation with 100 V to 230 V

129



### Controller C 3

- Expandible modular Controller for item Motors
- For three-phase operation with 230 V to 480 V

130



### Safety Module STO

- Puts Motor into a no-torque state when at rest
- Plug-in module for item C-series Controllers

131



### Fieldbus interface cards

- For EtherCAT, PROFIBUS or PROFINET
- Plug-in modules for C-series Controllers

132



### Cables

- Shielded, colour-coded Power and Data Cables
- Preconfigured in numerous lengths

133



### Shield Terminal Block D14

- Efficient EMC shielding
- Prevents interference at exposed connections

137



## Controller BL 1-04/C

- Extensive series-standard configuration
- Very compact design
- High controller quality with high sampling rate

item Controller BL 1-04/C is a highly integrated servo controller that has been perfectly configured for item Linear Units and drive technology. All key functions and interfaces are included as standard.

A high-quality controller with short sampling times and a state-of-the-art programming environment helps deliver productive applications. Thanks to its compact design, the Controller takes up little space in the enclosure.

All key hardware interfaces are integrated in the compact housing as standard. EtherCAT, PROFINET and CANopen are available as the fieldbus. Safe Torque Off (STO) and Safe Stop 1 (SS1) to EN 61800-5-2 are also included in the scope of supply. A USB and Ethernet port complete the offering.

During operation, high-quality controllers with a sampling time of less than 32  $\mu$ s support extremely precise control over dynamic processes. When it comes to evaluating the rotary encoder, the Controller supports HIPERFACE<sup>®</sup>, HIPERFACE DSL<sup>®</sup>, EnDat 2.2, resolvers and digital absolute encoders.

As is usually the case at item, Controller BL 1-04/C also supports automatic parametrisation using item MotionSoft<sup>®</sup> and I/O simulation for program development. The Controller can be used with all item Motors that have a power consumption of up to 4 A single phase (100 V to 230 V).

### Compact design and extensive series-standard configuration

LED status indicator

Integrated STO (Safe Torque Off) safety function: Front-mounted circuitry for connecting to an external safety switching device in order to activate the "Safe Stop 1" (SS1, type C) function

Integrated USB and Ethernet interface: Programming and transmission of motion profile via item MotionSoft<sup>®</sup>. Inputs and outputs can be simulated during development work.

Integrated fieldbus interfaces: 2x RSJ45 for EtherCAT and PROFINET

Integrated fieldbus interface: CANopen

Interface to encoder system: Support for HIPERFACE<sup>®</sup>, HIPERFACE DSL<sup>®</sup>, EnDat 2.2, resolvers and absolute encoders. item Data Cables are available in several lengths.



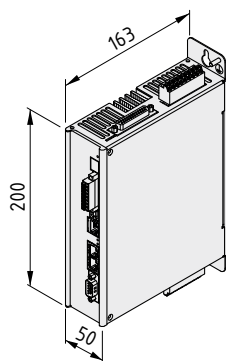

**Controller BL 1-04/C**

Supply voltage	1 x 100 ... 230 VAC (+- 10%), 50 ... 60 Hz
Control voltage	24 VDC (+-20 %) [0.55 A]
DC bus circuit voltage	360 ... 380 V / 310 ... 320 V (with/without Power Factor Control)
Output power (rated)	0.5 KVA
max. output power (for 5 s)	1 KVA

1 pce.	0.0.698.50
--------	------------



## Controllers C 1-02, -05

- Intelligent, programmable Controllers for item Motors
- For single-phase operation with 100 V to 230 V
- Can be expanded using plug-in cards

item Controllers C 1 are modular, programmable servo controllers designed for single-phase operation. Models C 1-02 and C 1-05 differ in terms of their output power.

USB, Ethernet, RS-232 and CANopen interfaces are series standard. All standard fieldbus systems can be expanded using additional interface modules. This means you can easily retrofit EtherCAT, PROFIBUS and PROFINET. Safety Module STO (Safe Torque Off) makes things even safer by putting the Motor into a no-torque state when at rest.

To ensure precise motion over long-term use, the Controller features integrated encoder interfaces for resolvers and absolute encoders.

You can save motion profiles directly to the Controller. Signals for start/stop switches, sensors, etc. can also be processed in the program sequence. Freely programmable I/O ports are available for this purpose. Setup and programming work is carried out using the intuitive software program item MotionSoft®.

item Controllers have CE and UL certifications.

**Note:** Shield Terminal Block D14 (0.0.668.19) from item should be used to ensure problem-free signal processing.

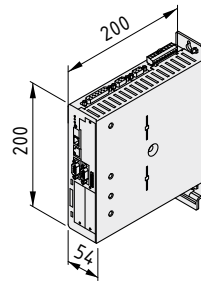

### Controller C 1-02

Supply voltage	1 x 100 ... 230 VAC (+- 10%) , 50 ... 60 Hz
Control voltage	24 VDC (+-20 %) [0.55 A]
DC bus circuit voltage	360 ... 380 V / 310 ... 320 V (with/without Power Factor Control)
Output power (rated)	0.5 KVA
max. output power (for 5 s)	1 KVA

1 pce. 0.0.668.62

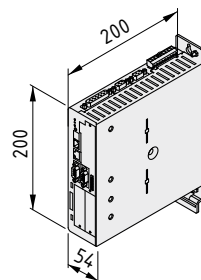

### Controller C 1-05

Supply voltage	1 x 100 ... 230 VAC (+- 10%) , 50 ... 60 Hz
Control voltage	24 VDC (+-20 %) [0.65 A]
DC bus circuit voltage	360 ... 380 V / 310 ... 320 V (with/without Power Factor Control)
Output power (rated)	1.0 KVA
max. output power (for 5 s)	2 KVA

1 pce. 0.0.668.63



## Controller C 3-05

- Intelligent, programmable Controller for item Motors
- For three-phase operation with 230 V to 480 V
- Can be expanded using plug-in cards

Controller C 3-05 is a modular, programmable servo controller designed for three-phase operation.

USB, Ethernet, RS-232 and CANopen interfaces are series standard. All standard fieldbus systems can be expanded using additional interface modules. This means you can easily retrofit EtherCAT, PROFIBUS and PROFINET. Safety Module STO (Safe Torque Off) makes things even safer by putting the Motor into a no-torque state when at rest.

To ensure precise motion over long-term use, the Controller features integrated encoder interfaces for resolvers and absolute encoders.

You can save motion profiles directly to the Controller. Signals for start/stop switches, sensors, etc. can also be processed in the program sequence. Freely programmable I/O ports are available for this purpose. Setup and programming work

is carried out using the intuitive software program item MotionSoft®.

item Controllers have CE and UL certifications.

**Note:** Shield Terminal Block D14 (0.0.668.19) from item should be used to ensure problem-free signal processing.

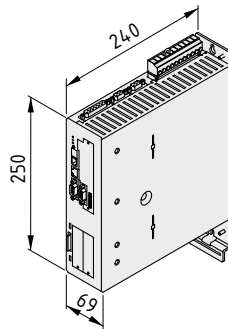

### Controller C 3-05

Supply voltage	3 x 230 ... 480 VAC (+- 10%) , 50 ... 60 Hz
Control voltage	24 VDC (+-20 %) [1 A]
DC bus circuit voltage	560 ... 570 V
Output power (rated)	3 KVA
max. output power (for 5 s)	6 KVA

1 pce.

0.0.668.65





## Safety Module STO

- Plug-in module for item C-series Controllers
- Puts drive into a no-torque state when at rest
- Maximum safety to EN ISO 13849-1 and 61800-5-2

Safety Module STO (Safe Torque Off) is an expansion add-on for item Controllers in the C series. It ensures that, when at rest, the Motor does not produce any effective torque. This means the system is shut down safely when, for example, the emergency shutdown button is pressed or a door is opened.

The Module is slotted into one of the expansion slots. All applicable safety standards are reliably met, including category 4/PLe to EN ISO 13849-1 and SILCL 3 to EN 62061.

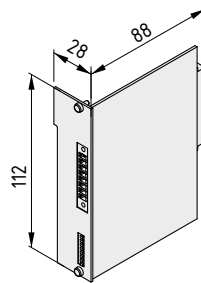

### STO Safety Module

m = 72.0 g

1 pce.

0.0.668.20





## Interface cards EtherCAT/PROFIBUS/PROFINET

- Plug-in module for item C-series Controllers
- For additional fieldbus connections

The plug-in modules connect item C-series Controllers to system environments via the EtherCAT, PROFIBUS or PROFINET fieldbus standards.

As plug-and-play solutions, the modules are simply inserted into one of the expansion slots. The necessary connections for the relevant network are located at the front of the modules.

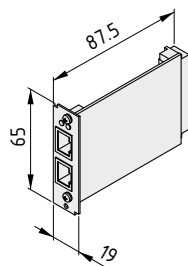

### EtherCAT Interface

m = 45.0 g

1 pce.

0.0.668.15

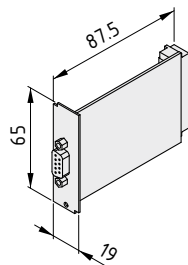

### PROFIBUS Interface

m = 46.0 g

1 pce.

0.0.668.14

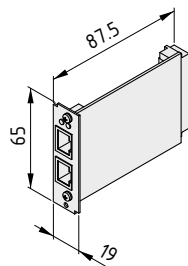

### PROFINET Interface

m = 46.0 g

1 pce.

0.0.681.66

## Cables

- Ready-to-connect Power and Data Cables in standard lengths
- Suitable for drag chains and with EMC shielding
- Colour-coded and tamperproof



To prevent interference, the interplay between the Motor and Controller is handled via two separate cables: The orange Power Cable feeds power to the Motor, while the green Data Cable is reserved for data transfer. Different connectors and colour coding make the separate types of cable unmistakable on site and ensure they are not connected to the wrong terminal.

All cables are available in standard lengths. The abbreviation BL in a product name indicates that the cable can be connected to BL-series Controllers.

Data Cables feature EMC shielding and must be ordered as appropriate to the Motor. The letters RSC indicate that a cable is for use with Motors that have a resolver, while the letters AKSC indicate suitability for Motors with an absolute encoder.

When selecting Power Cables for C-series Controllers, it is important to choose the correct type of cable for the load involved.



### Note:

Detailed nomenclature for the cables can be found in the Technical Data section. If you are using item MotionDesigner® to configure a complete system, the software will automatically select the correct cable.

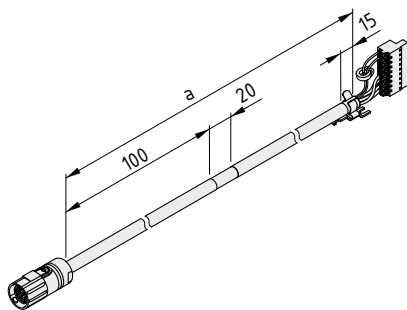

### Power Cable BL SC1 04/5

Smallest possible bend radius (when fixed in place) 46 mm

Smallest possible bend radius (repeated movement) 87 mm

a = 5000 mm m = 1.0 kg

orange, 1 pce.

0.0.703.51

### Power Cable BL SC1 04/10

Smallest possible bend radius (when fixed in place) 46 mm

Smallest possible bend radius (repeated movement) 87 mm

a = 10000 mm m = 2.0 kg

orange, 1 pce.

0.0.704.65

### Power Cable BL SC1 04/15

Smallest possible bend radius (when fixed in place) 46 mm

Smallest possible bend radius (repeated movement) 87 mm

a = 15000 mm m = 3.0 kg

orange, 1 pce.

0.0.704.66

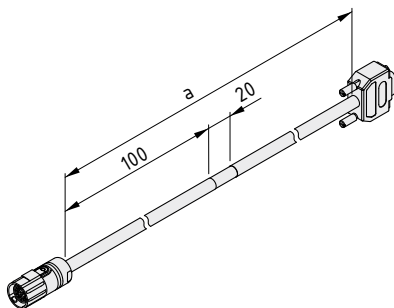

<b>Data Cable BL RSC/5</b>	
Smallest possible bend radius (when fixed in place)	30 mm
Smallest possible bend radius (repeated movement)	63 mm
a = 5000 mm	m = 660.0 g
green, 1 pce.	0.0.704.71

<b>Data Cable BL RSC/10</b>	
Smallest possible bend radius (when fixed in place)	30 mm
Smallest possible bend radius (repeated movement)	63 mm
a = 10000 mm	m = 1.2 kg
green, 1 pce.	0.0.704.72

<b>Data Cable BL RSC/15</b>	
Smallest possible bend radius (when fixed in place)	30 mm
Smallest possible bend radius (repeated movement)	63 mm
a = 15000 mm	m = 1.8 kg
green, 1 pce.	0.0.704.73

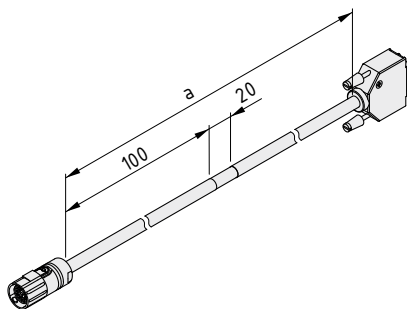

<b>Data Cable BL AKSC/5</b>	
Smallest possible bend radius (when fixed in place)	45 mm
Smallest possible bend radius (repeated movement)	93 mm
a = 5000 mm	m = 670.0 g
green, 1 pce.	0.0.704.75

<b>Data Cable BL AKSC/10</b>	
Smallest possible bend radius (when fixed in place)	45 mm
Smallest possible bend radius (repeated movement)	93 mm
a = 10000 mm	m = 1.2 kg
green, 1 pce.	0.0.704.76

<b>Data Cable BL AKSC/15</b>	
Smallest possible bend radius (when fixed in place)	45 mm
Smallest possible bend radius (repeated movement)	93 mm
a = 15000 mm	m = 1.8 kg
green, 1 pce.	0.0.704.77

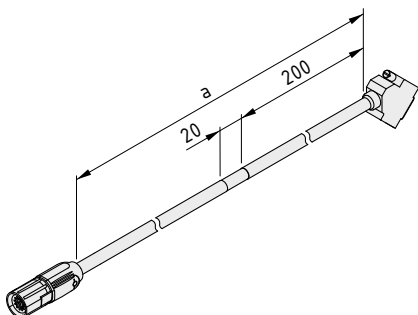

<b>Data Cable RSC/5</b>	
Smallest possible bend radius (when fixed in place)	30 mm
Smallest possible bend radius (repeated movement)	63 mm
a = 5000 mm	m = 587.0 g
green, 1 pce.	0.0.670.27

<b>Data Cable RSC/10</b>	
Smallest possible bend radius (when fixed in place)	30 mm
Smallest possible bend radius (repeated movement)	63 mm
a = 10000 mm	m = 1.1 kg
green, 1 pce.	0.0.671.89

<b>Data Cable RSC/15</b>	
Smallest possible bend radius (when fixed in place)	30 mm
Smallest possible bend radius (repeated movement)	63 mm
a = 15000 mm	m = 1.6 kg
green, 1 pce.	0.0.691.38

**Data Cable RSC/20**

Smallest possible bend radius (when fixed in place)	30 mm
Smallest possible bend radius (repeated movement)	63 mm
a = 20000 mm	m = 2.2 kg

green, 1 pce. 0.0.691.39

**Data Cable RSC/25**

Smallest possible bend radius (when fixed in place)	30 mm
Smallest possible bend radius (repeated movement)	63 mm
a = 25000 mm	m = 2.7 kg

green, 1 pce. 0.0.691.40

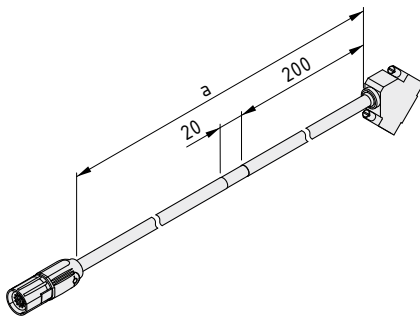

**Data Cable AKSC/5**

Smallest possible bend radius (when fixed in place)	45 mm
Smallest possible bend radius (repeated movement)	93 mm
a = 5000 mm	m = 682.0 g

green, 1 pce. 0.0.688.53

**Data Cable AKSC/10**

Smallest possible bend radius (when fixed in place)	45 mm
Smallest possible bend radius (repeated movement)	93 mm
a = 10000 mm	m = 1.3 kg

green, 1 pce. 0.0.688.54

**Data Cable AKSC/15**

Smallest possible bend radius (when fixed in place)	45 mm
Smallest possible bend radius (repeated movement)	93 mm
a = 15000 mm	m = 1.7 kg

green, 1 pce. 0.0.691.41

**Data Cable AKSC/20**

Smallest possible bend radius (when fixed in place)	45 mm
Smallest possible bend radius (repeated movement)	93 mm
a = 20000 mm	m = 2.3 kg

green, 1 pce. 0.0.691.42

**Data Cable AKSC/25**

Smallest possible bend radius (when fixed in place)	45 mm
Smallest possible bend radius (repeated movement)	93 mm
a = 25000 mm	m = 2.9 kg

green, 1 pce. 0.0.691.43

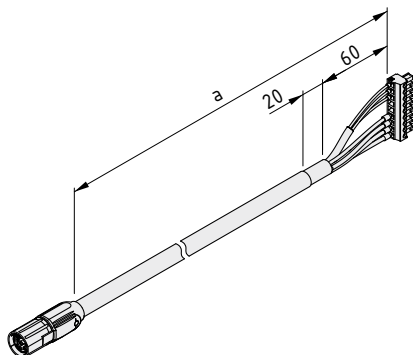

**Power Cable SC1 05/5**

Smallest possible bend radius (when fixed in place)	46 mm
Smallest possible bend radius (repeated movement)	87 mm
a = 5000 mm	m = 965.0 g

orange, 1 pce. 0.0.670.28

**Power Cable SC1 05/10**

Smallest possible bend radius (when fixed in place)	46 mm
Smallest possible bend radius (repeated movement)	87 mm
a = 10000 mm	m = 1.9 kg

orange, 1 pce. 0.0.671.90

**Power Cable SC1 05/15**

Smallest possible bend radius (when fixed in place)	46 mm
Smallest possible bend radius (repeated movement)	87 mm
a = 15000 mm	m = 2.8 kg

orange, 1 pce. 0.0.691.35

**Power Cable SC1 05/20**

Smallest possible bend radius (when fixed in place)	46 mm
Smallest possible bend radius (repeated movement)	87 mm
a = 20000 mm	m = 3.7 kg

orange, 1 pce. 0.0.691.36

**Power Cable SC1 05/25**

Smallest possible bend radius (when fixed in place)	46 mm
Smallest possible bend radius (repeated movement)	87 mm
a = 25000 mm	m = 4.6 kg

orange, 1 pce. 0.0.691.37

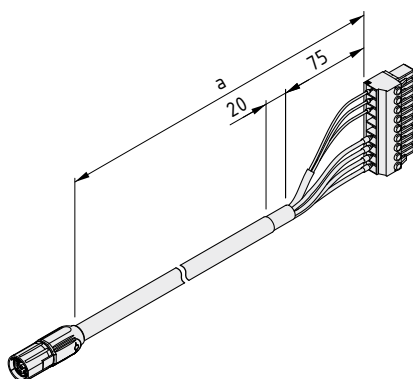

**Power Cable SC3 10/5**

Smallest possible bend radius (when fixed in place)	46 mm
Smallest possible bend radius (repeated movement)	87 mm
a = 5000 mm	m = 992.0 g

orange, 1 pce. 0.0.670.30

**Power Cable SC3 10/10**

Smallest possible bend radius (when fixed in place)	46 mm
Smallest possible bend radius (repeated movement)	87 mm
a = 10000 mm	m = 1.9 kg

orange, 1 pce. 0.0.671.92



### Shield terminal block D14

- Efficient EMC shielding
- Enables fault-free operation

Interference at exposed connections is a frequent cause of errors. Shield Terminal Block D14 ensures data is transferred correctly and thus safeguards fault-free operation.

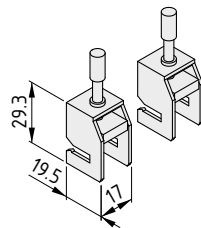

### Shield Clamp D14

m = 40.0 g

bright zinc-plated, 1 set

0.0.668.19



## Accessories for Linear Units

item accessories offer you fully compatible expansion elements for item Linear Units. They include Carriage Plates and Limit Stops that have been optimised for the relevant models. Proximity Switches expand the functional scope to suit your application.

Accessories also include useful maintenance products that will help you ensure your item Linear Unit continues to provide outstanding performance long into the future.



## Products in this section



### Linear Guides 6 60 PS

- Compact and strong
- Additional torque accommodation for entire systems

140

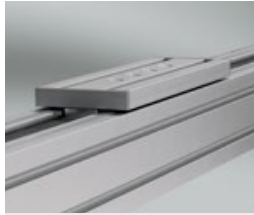

### Carriage Plates and Transverse Carriage Plates

- Simple means of connecting applications
- Also suitable for strong multi-axis systems

141



### Profile Fastening Set 6/8 80x60

- Fastens Linear Units with a Line 6 groove to Line 8 profiles
- Self-centring

143



### Slide Stop LRE 8

- Robust stop made from aluminium
- Also suitable for retrofitting

144



### Proximity Switches

- Inductive proximity detection
- For building customised solutions

145



### Proximity Switch Sets

- Inductive proximity detection
- All components in one set

148



### I/O Interface Module (C Series)

- Freely assignable D-Sub 25 connector
- Custom connection of sensors to the C series

150



### Pin Spanners

- For adjusting bearing units
- For roller guides and C-Rail Guides

151



### Track Oil / Oil Can for Linear Guides

- Increase the service life of linear guides
- High-quality, fully synthetic oils

152



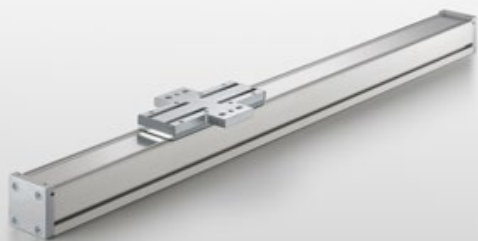

## Linear Guides 6 60 PS

- Encapsulated components
- Compact, precise and torsion resistant
- High torque accommodation



Linear Guide 6 60 PS consists of a torsion-resistant profile rail and two heavy-duty recirculating ball units. The encapsulated turnkey guide solution is ideal for precise, low-friction movements.

As a parallel guide, it can help a driven Linear Unit accommodate larger loads and torques. The version with a Transverse Carriage Plate is particularly effective at simplifying the construction of parallel linear technology solutions.

Thanks to its installation dimensions of just 60x60 mm and two Line 6 grooves on its side flanks, the Linear Guide is very easy to integrate into constructions.

If the Linear Guide is being used in parallel with a Linear Unit, the safety clearance of the Linear Unit must be factored in when designing the stroke. The stroke of the Linear Guide must be extended accordingly:  $H = H_{LU} + X$

Linear Unit	Art. No.	$H_{LU}$ [mm]	X [mm]	Linear Guide 6 60 PS	
Linear Unit KLE 6 60x60 LR	0.0.605.07	0 - 2644	172	$F_{y\max}$ [N] = $F_{z\max}$ [N]	2000
Linear Unit KGT 6 60 P20	0.0.706.00	0 - 1000	95	$M_{x\max}$ [Nm]	15
		1001 - 1560	127	$M_{y\max}$ [Nm] = $M_{z\max}$ [Nm]	120
		1561 - 2120	159		
		2121 - 2600	191		

$H$  = Stroke of the Guide  $H_{LU}$  = Stroke of the Linear Unit

The design takes into account that the Linear Unit, combined with the parallel Linear Guide 6 60 PS, is not restricted in terms of movement and that the total lengths  $L$  of the Guide and Linear Unit are identical.

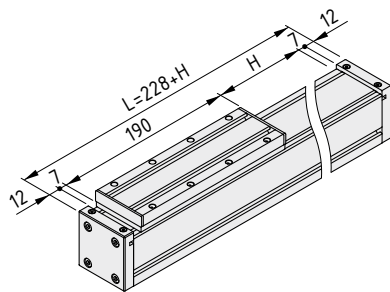

### Linear Guide 6 60 PS (zero stroke)



Maximum stroke $H_{\max}$	2816	mm
Basic mass (when stroke length = 0 mm) $m_1$	2.2	kg
Mass per mm of stroke $m_2$	3.4	g/mm
Total mass $m =$	$m_1 + H \cdot m_2$	
Maximum acceleration	15	$m/s^2$
Maximum travelling speed	1	m/s

1 set

0.0.701.69

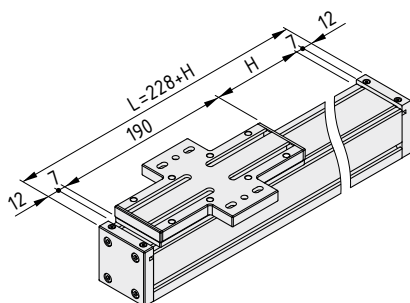

### Linear Guide 6 60 PS Transverse Carriage (zero stroke)



Maximum stroke $H_{\max}$	2816	mm
Basic mass (when stroke length = 0 mm) $m_1$	2.3	kg
Mass per mm of stroke $m_2$	3.4	g/mm
Total mass $m =$	$m_1 + H \cdot m_2$	
Maximum acceleration	15	$m/s^2$
Maximum travelling speed	1	m/s

1 set

0.0.708.77



## Carriage Plates and Transverse Carriage Plates

- Compatible with Linear Units KLE and 6 60 P20
- Profile grooves provide universal fastening options
- Robust Transverse Carriage Plate for building multi-axis systems



A secure hold for all superstructures. These standardised Carriage Plates feature all the fastening holes and elements needed to secure attachments to the carriages of item Linear Units KLE and 60 6 P20 and Linear Guide 6 60 PS.

Transverse Carriage Plates significantly speed up the process of designing, building and commissioning multi-axis systems. Only a small number of components is needed to design a secure and robust complete system.

Profiles X 6 60x12 (0.0.609.32) and X 8 80x16 (0.0.609.34) with matching Caps are available for constructing carriage plates in custom lengths.

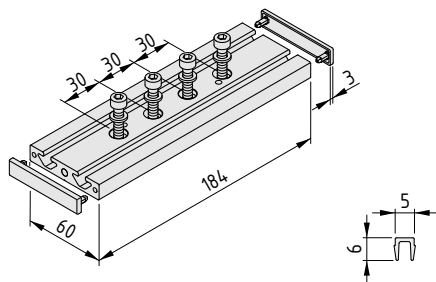

### Carriage Plate KLE 6 60x60

Profile X 6 60x12, Al natural  
 2 Caps X 6 60x12, PA-GF, grey  
 4 Hexagon Socket Head Cap Screws DIN 912-M6x25, St, bright zinc-plated  
 4 Washers DIN 433-6.4, St, bright zinc-plated  
 m = 275.0 g

1 set 0.0.609.25

### Cover Profile 6 LE

PP/TPE  
 m = 13.0 g/m

grey similar to RAL 7042, 1 pce., length 2000 mm 0.0.603.88

grey similar to RAL 7042, cut-off max. 2000 mm 0.0.605.10

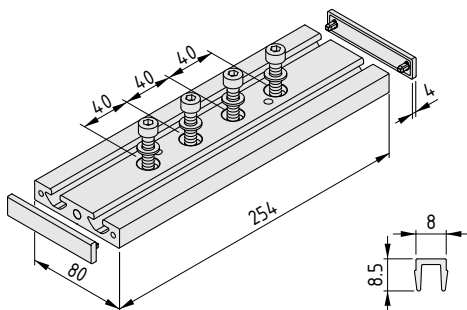

### Carriage Plate KLE 8 80x80

Profile X 8 80x16, Al natural  
 2 Caps 8 80x16, PA-GF, grey  
 4 Hexagon Socket Head Cap Screws DIN 912-M8x30, St, bright zinc-plated  
 4 Washers DIN 433-8.4, St, bright zinc-plated  
 m = 675.0 g

1 set 0.0.609.24

### Cover Profile 8 LE

PP/TPE  
 m = 28.5 g/m

grey similar to RAL 7042, 1 pce., length 2000 mm 0.0.600.54

grey similar to RAL 7042, cut-off max. 2000 mm 0.0.605.05

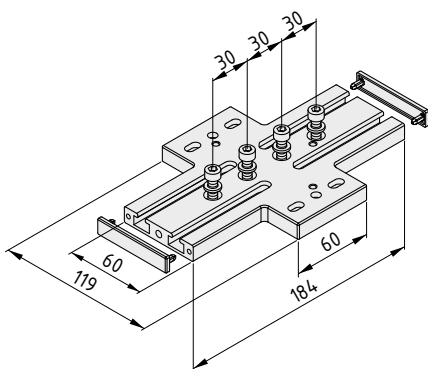

**Transverse Carriage Plate KLE 6 60x60**



- 1 Transverse Carriage Plate KLE 6 60x60, Al
- 2 Caps X 6 60x12, PA-GF, grey
- 4 Hexagon Socket Head Cap Screws DIN 912-M6x25, St, bright zinc-plated
- 4 washers DIN 433-6.4, St, bright zinc-plated
- m = 367.4 g

1 set

0.0.692.19

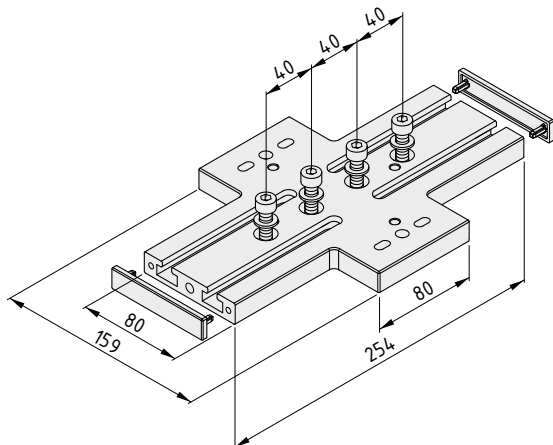

**Transverse Carriage Plate KLE 8 80x80**



- 1 Transverse Carriage Plate KLE 8 80x80, Al
- 2 Caps X 8 80x16, PA-GF, grey
- 4 Hexagon Socket Head Cap Screws DIN 912-M8x30, St, bright zinc-plated
- 4 washers DIN 433-8.4, St, bright zinc-plated
- m = 931.2 g

1 set

0.0.692.61

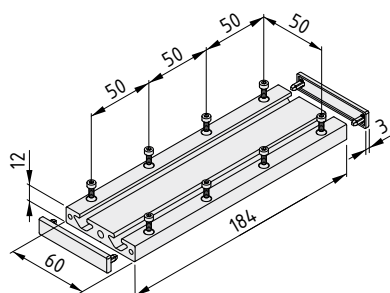

**Carriage Plate 6 60 190x60**



- Profile X 6 60x12, Al, natural
- 2 Caps X 6 60x12, PA-GF, grey
- 8 Hexagon Socket Head Cap Screws DIN 912-M3x8, St, bright zinc-plated
- m = 247.0 g

1 set

0.0.708.76

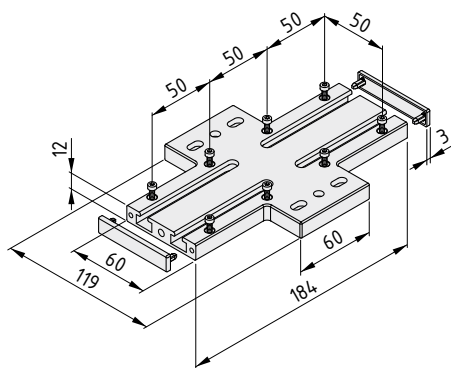

**Transverse Carriage Plate 6 60 190x119**



- Transverse carriage plate 6 60x60, Al
- 2 Caps X 6 60x12, PA-GF, grey
- 8 Hexagon Socket Head Cap Screws DIN 912-M3x8, St, bright zinc-plated
- m = 350.0 g

1 set

0.0.708.75



## Profile Fastening Set 6/8 80x60

- Adapter for Line 6
- Fastens to a Line 8 groove
- For connecting Linear Units



Profile Fastening Set 6/8 80x60 creates a friction-based connection between a component that has a Line 6 groove on its side and a base that features a Line 8 groove. This means, for example, that a 60 mm-wide Linear Unit can be fastened to a Line 8 support profile. The installation process is very easy and the shape of the fastener means that the components centre themselves.



Load specifications for Profile Fastening Set 6/8 80x60:

$F_{x \max}$ [N]	$F_{y \max}$ [N]	$F_{z \max}$ [N]
500	500	500

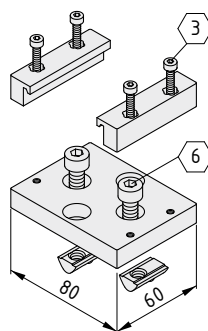
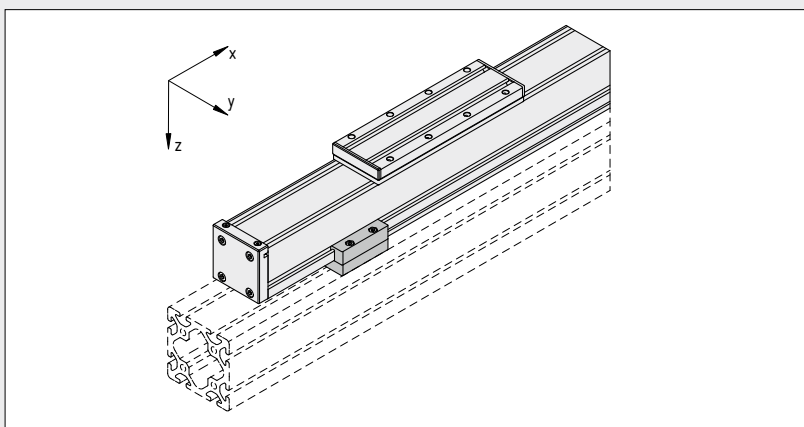

### Profile Fastening Set 6/8 80x60



- Adapter plate, Al
- 2 clamping pieces
- 2 Hexagon Socket Head Cap Screws DIN 912 M8x14, St, bright zinc-plated
- 4 Hexagon Socket Head Cap Screws DIN 912 M4x20, St, bright zinc-plated
- 2 T-Slot Nuts V 8 St M8, St, bright zinc-plated
- $m = 243.0 \text{ g}$

1 set

0.0.708.20



## Slide Stop LRE 8

- Robust stop made from aluminium
- Simple to install



Keep everything on track! Sturdy Slide Stop LRE 8 stops the carriage of a Linear Unit from overshooting the calculated or desired point. The aluminium travel limiter delivers added safety.

Slide Stop LRE 8 can be easily secured – and even retrofitted – to the Line 8 groove of a Linear Unit LRE. Thanks to its special shape, the Slide Stop can be used with shafts in various diameters and fitted at any position, making it a universal solution.

**Note:** When configured using item MotionDesigner®, most LRE-type Linear Units from item are automatically fitted with a Slide Stop that can be moved to a different position or removed entirely, as required. Some models, such as Linear Units KLE are designed in such a way that an additional Slide Stop is unnecessary.

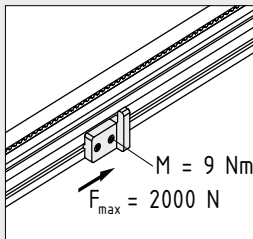

Max. load

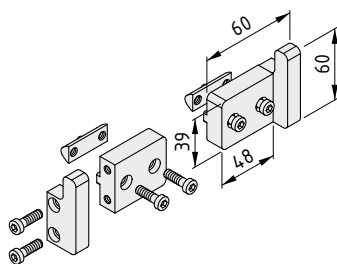

### Slide Stop LRE 8



- 2 carriers, Al
- 2 stops, Al
- 2 T-Slot Nuts 8 St 2xM6-36
- 8 Hexagon Socket Head Cap Screws DIN 6912-M6x20
- m = 283.0 g

1 set

0.0.686.50



## Proximity Switch

- Inductive proximity switch for added safety in linear drives
- Installed in Line 8 groove (Proximity Switch 8)
- Installed in Timing-Belt Reverse Unit (Proximity Switch M8)



Proximity Switch M8 is a versatile device for limiting the terminal position or for reference on Linear Units with timing-belt drives. It is available with a permanent or plug-in connecting cable.

The Proximity-Switch Cam is used to mark the terminal position and/or the reference point of the unit on the Timing Belt.

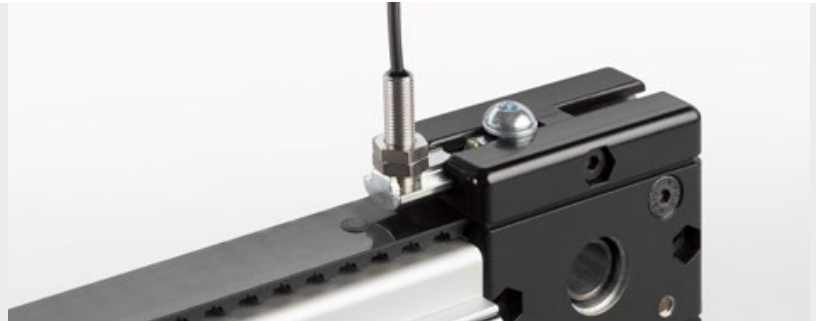

The Proximity-Switch Fastening Set is used to position and attach inductive Proximity Switches M8 on the Timing-Belt Reverse Units.

Proximity-Switch Connecting Cable in plug-in design with integrated LEDs for displaying the switch function and operating voltage.

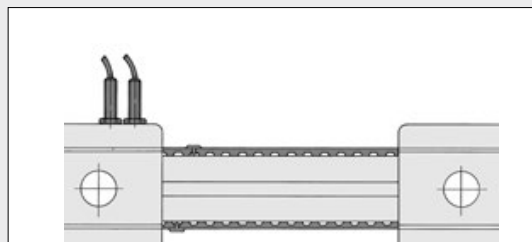

Possible arrangement of Proximity Switches 8 and Proximity-Switch Cams 8:  
The Proximity-Switch Cams run through the Timing-Belt Reverse Units.

Particularly suitable when used with the drive end Timing Belt Reverse Unit for simplifying cable routing between the drive unit, Proximity Switch and motor control unit.

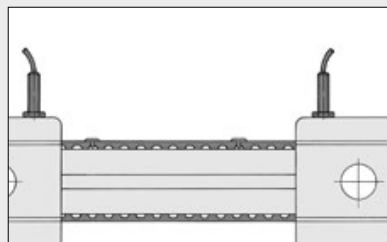

Possible arrangement of Proximity Switches 8 and Proximity-Switch Cams 8:  
The Proximity-Switch Cams do not run through the Timing-Belt Reverse Units.

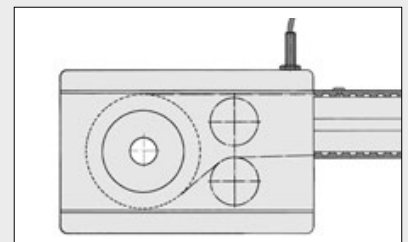

When using a system that reverses the timing belt via contact with its flat side (Timing-Belt Counter-Reverse Unit 8 R25/ Timing-Belt Reverse Unit 8 80 R25 with emergence 40 mm), Proximity-Switch Cams 8 must not pass through the Timing-Belt Reverse Units. In this case, Proximity Switches 8 and Proximity-Switch Cams 8 must be positioned to prevent this from happening.

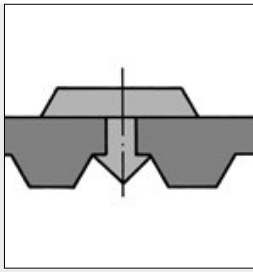

Proximity-Switch Cam 8 is pressed into the flat side of the Timing Belt at the required positions.

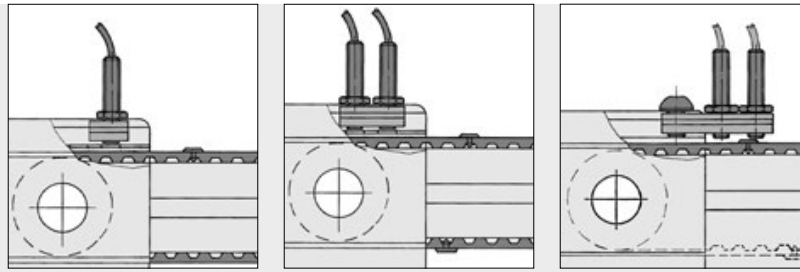

Options for installing Proximity Switches 8 using the Proximity-Switch Fastening Set. Depending on the application, the Proximity-Switch Fastening Set must be shortened accordingly.

Proximity Switch 8 is particularly suitable in conjunction with Timing-Belt Reverse Units 8 or Timing-Belt Counter-Reverse Unit 8, Proximity-Switch Fastening Set 8 and Proximity-Switch Cams 8. Timing-Belt Reverse Units 8 are provided with openings for the Proximity Switch at appropriate points in order to ensure compact installation.

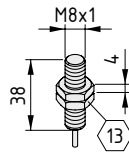

**Proximity Switch M8**



St, stainless  
 Inductive Proximity Switch, positive switching,  
 suitable for installation in thread M8x1  
 Voltage = 10...30 V DC  
 Max. switching current = 200 mA  
 Sensing range = 1.5 mm  
 LED control display  
 Connecting cable, black l = 3 m; d = 3.5 mm  
 m = 54.0 g

1 pce. 0.0.337.14

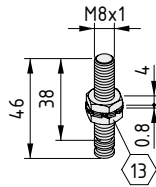

**Proximity Switch M8, Plug Connection**



St, stainless  
 Inductive Proximity Switch, positive switching,  
 suitable for installation in thread M8x1  
 Voltage = 10...30 V DC  
 Max. switching current = 200 mA  
 Sensing range = 1.5 mm  
 LED control display  
 m = 16.0 g

1 pce. 0.3.001.24

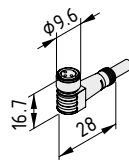

**Proximity-Switch Connecting Cable**



Outer sheath PUR, grey  
 Structure Lif9YH11YH, 3x0.25 mm<sup>2</sup>  
 Plug: integrated 3-pole plug with metal collar M8x1  
 Cable inlet angled by 90°  
 LED control display: Green = Operating display, Yellow/orange = Switch function display  
 Connecting cable l = 5 m; d = 4.0 mm  
 m = 144.0 g

1 pce. 0.3.001.25

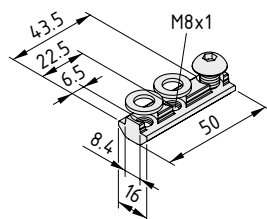

**Proximity-Switch Fastening Set 8**



St  
 2 washers DIN 433 8.4, St, bright zinc-plated  
 Button-Head Screw ISO 7380 M8x10, St, bright zinc-pl.  
 m = 37.0 g

1 set 0.0.337.31



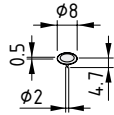

<b>Proximity-Switch Cam 8</b>	
St m = 0.2 g	
black, 1 pce.	0.0.337.15

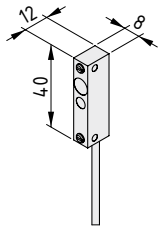

<b>Proximity Switch 8 - 1NC</b>	
Inductive Proximity Switch, positive switching Casing Al, anodized, natural Fixing mechanism, fixing screws Voltage = 10...30 V DC Switching current <sub>max</sub> = 150 mA Sensing range = 2 mm Cable, grey l = 3 m ; d = 3 mm m = 51.0 g	
1 pce.	0.0.600.05

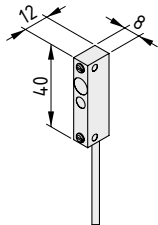

<b>Proximity Switch 8 - 1NO</b>	
Inductive Proximity Switch, positive switching Casing Al, anodized, natural Fixing mechanism, fixing screws Voltage = 10...30 V DC Switching current <sub>max</sub> = 150 mA Sensing range = 2 mm Cable, grey l = 3 m ; d = 3 mm m = 51.0 g	
1 pce.	0.3.001.30

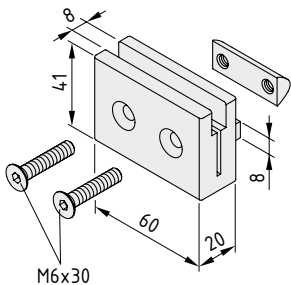

<b>Limit-Switch Holder KRF 8</b>	
Holder, Al, natural 2 Countersunk Screws DIN 7991-M6x30, St, bright zinc-plated T-Slot Nut 8 St 2xM6-36 m = 120.0 g	
1 pce.	0.0.626.55

**The following applies to all the products below:**

Inductive proximity switch, positive switching  
Housing Al, anodized, natural  
Fixing mechanism, fixing screws  
Voltage = 10...30 V DC  
Switching current<sub>max</sub> = 150 mA  
Operating distance = 2 mm  
Cable, grey, l = 10 m; d = 3 mm

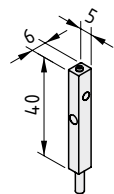

<b>Proximity Switch KLE 6 60x60 - 1NO</b>	
m = 125.0 g	
1 pce.	0.0.609.31

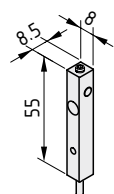

<b>Proximity Switch KLE 8 80x80 - 1NO</b>	
m = 125.0 g	
1 pce.	0.0.609.30

<b>Proximity Switch KLE 8 80x80 - 1NC</b>	
m = 125.0 g	
1 pce.	0.0.600.59





## Proximity Switch Sets

- Inductive proximity detection
- Compatible with item Linear Units
- All the parts you need in one package



Always know your limits! item Proximity Switches are used for homing and for identifying the end positions on Linear Units. They are inductive devices and send their signals to the Controller via a connecting cable.

The exact combination of components varies according to the model in use and where it is installed. Proximity Switch Sets contain all the components needed for Linear Units KRF, LRE and KGT. When placing an order, please note that some Proximity Switches are available in NO (normally open) and NC (normally closed) versions.

**Note:** item MotionSoft® commissioning software supports the use of Proximity Switches with item Controllers to ensure systems can be set up very quickly.

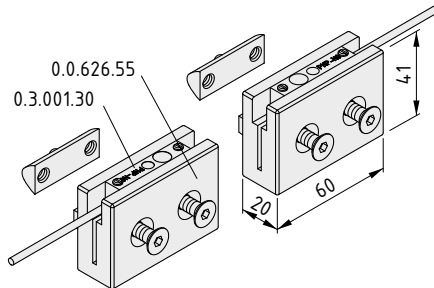

### Proximity Switch Set KRF NO



2 Limit-Switch Holders 8 KRF  
 2 Proximity Switches 8 - 1NO  
 Inductive Proximity Switch, positive switching  
 Casing Al, anodized, natural  
 Fixing mechanism, fixing screws  
 Voltage = 10...30 V DC  
 Switching current<sub>max</sub> = 150 mA  
 Sensing range = 2 mm  
 Cable, grey l = 3 m ; d = 3 mm  
 m = 384.0 g

1 pce.

0.0.688.08

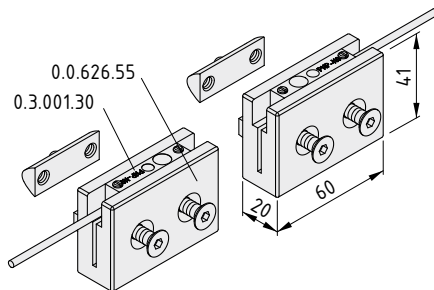

### Proximity Switch Set KRF NC



2 Limit-Switch Holders 8 KRF  
 2 Proximity Switches 8 - 1NC  
 Inductive Proximity Switch, positive switching  
 Casing Al, anodized, natural  
 Fixing mechanism, fixing screws  
 Voltage = 10...30 V DC  
 Switching current<sub>max</sub> = 150 mA  
 Sensing range = 2 mm  
 Cable, grey l = 3 m ; d = 3 mm  
 m = 384.0 g

1 pce.

0.0.688.09

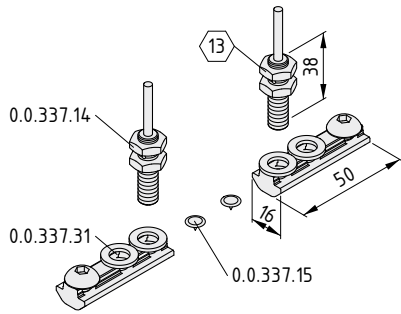

**Proximity Switch Set LRE NO**



2 Proximity Switch fixings 8  
 2 Proximity Switches M8  
 2 connecting cables, l = 3 m, d = 3.5 mm  
 2 Proximity-Switch Cams  
 Inductive Proximity Switch, positive switching,  
 suitable for installation in thread M8x1  
 Voltage = 10...30 V DC  
 Max. switching current = 200 mA  
 Sensing range = 1.5 mm  
 LED control display  
 m = 191.0 g

1 pce. 0.0.688.11

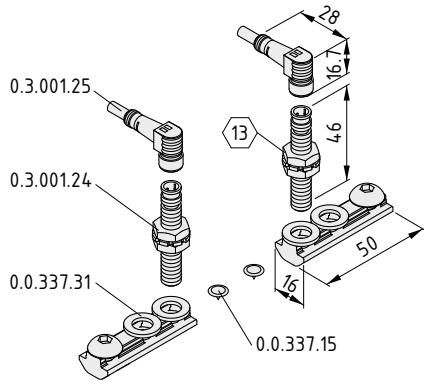

**Proximity Switch Set LRE NO, plug-in**



2 Proximity Switch fixings 8  
 2 Proximity Switches M8, plug-in  
 2 Proximity-Switch Connecting Cables, l = 5 m, d = 4 mm  
 2 Proximity-Switch Cams  
 Inductive Proximity Switch, positive switching,  
 suitable for installation in thread M8x1  
 Voltage = 10...30 V DC  
 Max. switching current = 200 mA  
 Sensing range = 1.5 mm  
 LED control display  
 m = 405.0 g

1 pce. 0.0.688.10

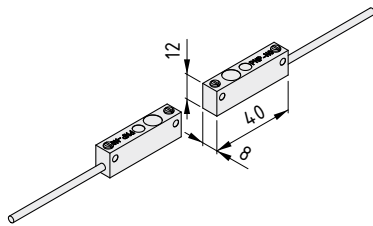

**Proximity Switch Set KGT NO**



2 Proximity Switches 8 - 1NO  
 Inductive Proximity Switch, positive switching  
 Casing Al, anodized, natural  
 Fixing mechanism, fixing screws  
 Voltage = 10...30 V DC  
 Switching current<sub>max</sub> = 150 mA  
 Sensing range = 2 mm  
 Cable, grey l = 3 m ; d = 3 mm  
 m = 110.0 g

1 pce. 0.0.688.12

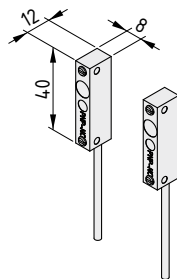

**Proximity Switch Set KGT NC**



2 Proximity Switches 8 - 1NC  
 Inductive Proximity Switch, positive switching  
 Casing Al, anodized, natural  
 Fixing mechanism, fixing screws  
 Voltage = 10...30 V DC  
 Switching current<sub>max</sub> = 150 mA  
 Sensing range = 2 mm  
 Cable, grey l = 3 m ; d = 3 mm  
 m = 110.0 g

1 pce. 0.0.688.13

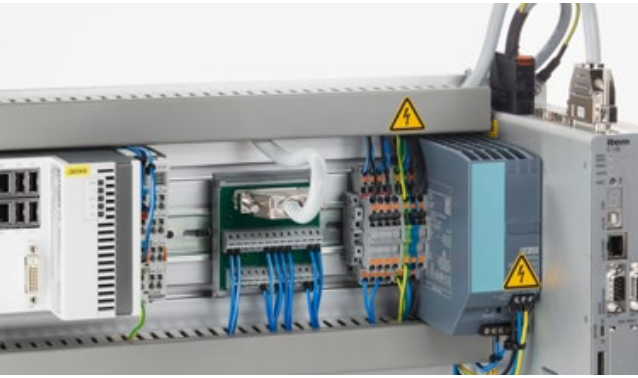

**I/O Interface Module (C Series)**  
**I/O Cable (C Series)**

- Freely assignable D-Sub 25 connector
- Custom connection of sensors
- For item C-series and BL-series Controllers

Communication made easy! All item C Series Controllers feature a standardised D-Sub 25 connection (DB-25). I/O Interface Module (C Series) can be used to combine signals from sensors etc. and easily link them up to the digital inputs and outputs of the item Controllers.

The industry-standard Interface Module is mounted on the support rail of an enclosure. Single-wire and fine-stranded conductors can be inserted into the terminal connections and the clear marking of the mounting base speeds up wiring work.

The I/O Interface Module (C Series) incorporates an integrated D-Sub 25 mating connector and is connected to the item Controller using a shielded I/O Cable (C Series). The end result is the flexibility to design a custom solution that slots perfectly into place.

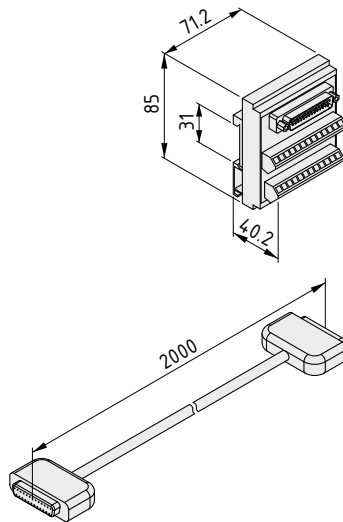

**I/O Interface Module (C Series)**

D-Sub 25 (pin header)  
 Single-wire and fine-stranded conductors 0.08 ... 2.5 mm<sup>2</sup> accommodated  
 Mounting type: Support rail 35  
 IP20 protection  
 m = 82.0 g

1 pce. 0.0.688.62

**I/O Cable (C Series)**

D-Sub 25 connection  
 Number of poles: 25  
 Cable length: 2 m  
 m = 372.0 g

1 pce. 0.0.689.27



## Pin Spanners

- For adjusting the eccentrics on roller guides and C-Rail Guides
- Makes it easier to tighten lock nuts



For tightening lock nuts in the Bearing Units of Roller Guides 5 D6, 8 D10, 8 D14 and 8 D25.

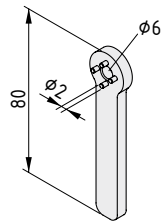

Pin Spanner 5 D6, 8 D10



St  
m = 40.0 g  
black, 1 pce.

0.0.390.13

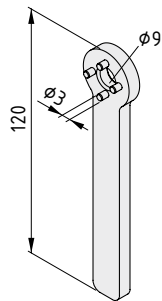

Pin Spanner 8 D14



St  
m = 90.0 g  
black, 1 pce.

0.0.294.41

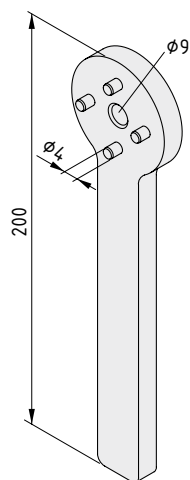

Pin Spanner 8 D25



St  
m = 430.0 g  
black, 1 pce.

0.0.350.30



## Track Oil for Linear Guides Oil Can for Linear Guides

- High-quality oils increase the service life of linear slides
- Ideal for product maintenance and care

The special Track Oil for Linear Guides is entirely synthetic and approved for contact with foodstuffs. It is used to maintain oil-lubricated guide tracks.



### Track Oil for Linear Guides

Synthetic lubrication oil ISO VG 460  
Contents: 250 ml (bottle)  
m = 285.0 g

1 pce.

0.0.612.75

### Oil Can for Linear Guides

Pump-action oil dispenser Al with pointed tip  
Contents: 200 ml  
m = 600.0 g

1 pce.

0.0.612.74



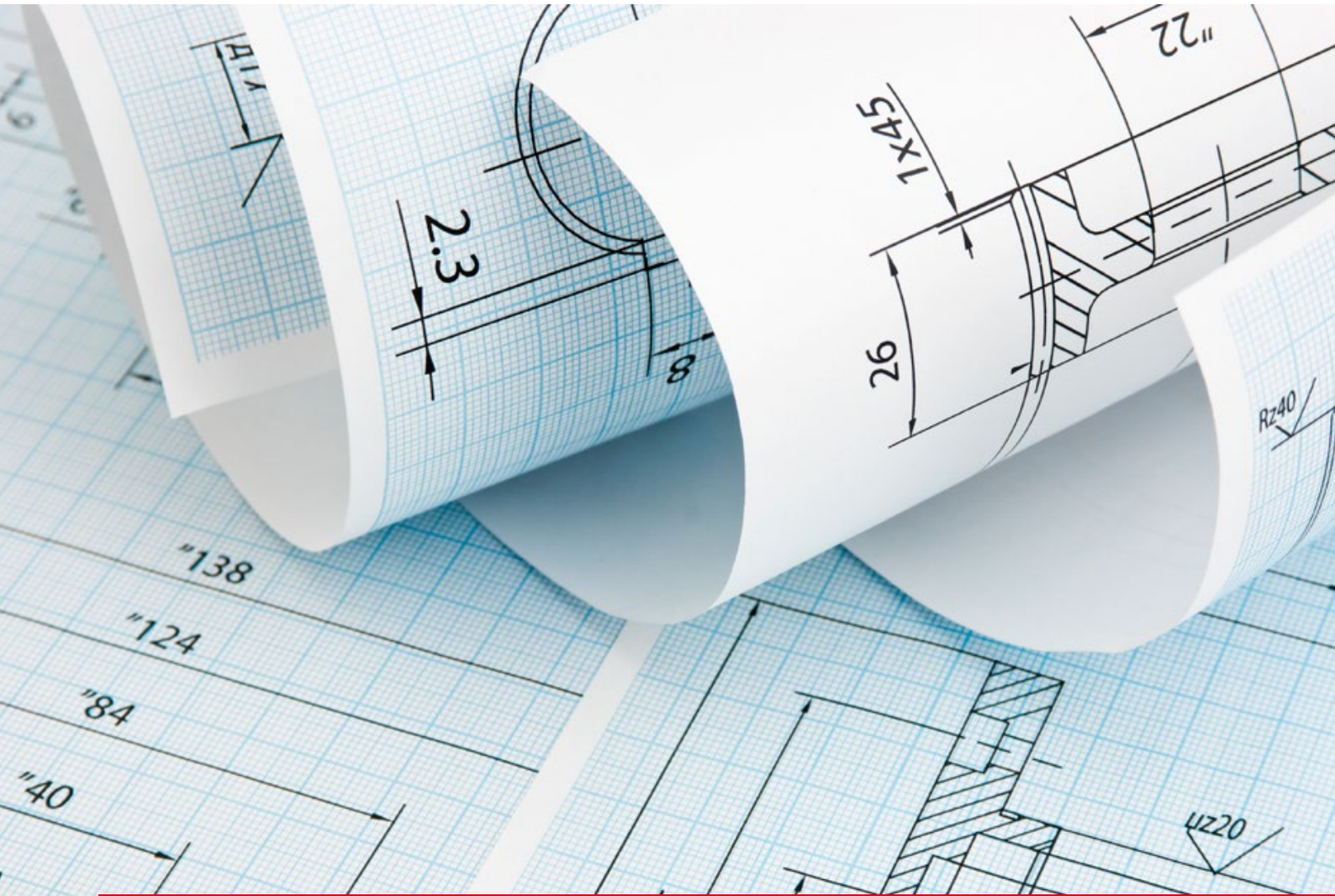

## Technical information

### The details at a glance:

The following pages contain all the facts and figures you need about service life, load-carrying capacity, technical features, etc. To make it easier to find the data you need, we have also summarised the most important details on the information pages for the Linear Units.

# Nomenclature of product names

## Nomenclature guide for Linear Units

GSF variant – T-slot slider with timing-belt drive

Linear Unit	Guide technology	Line	Support profile cross-section	Timing-belt type
Linear Unit	GSF	8	40	R10

GSF = T-slot slider                      R10 = Belt width 10 mm

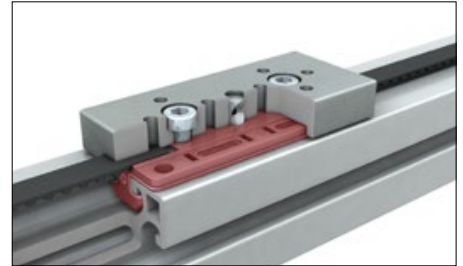

KLE variant – Internal roller guide with timing-belt drive

Linear Unit	Designation	Line	Support profile cross-section (H x W)	Guide technology
Linear Unit	KLE	6	60x60	LR

(Example)                      KLE = Compact Linear Unit                      LR = Roller element



KRF variant – Criss-crossed roller guide with timing-belt drive

Linear Unit	Guide technology	Line	Support profile cross-section (H x W)	Drive	Drive side
Linear Unit	KRF	8	80x40	ZR	Left

(Example)                      KRF = Criss-crossed roller guide                      ZR = Timing belt



LRE variant – External roller guide with various drives

Linear Unit	Guide technology	Line	Guiding shaft diameter	Support profile cross-section (H x W)	Drive	Dimension of drive
Linear Unit	LRE	5	D6	60x20	ZU	40 R10

(Example)                      LRE = Rolling element unit                      ZU = Timing-belt reverse unit

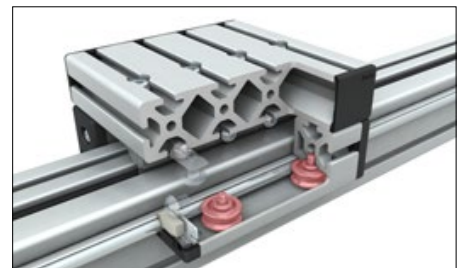

KGT variant – Profile rail guide with ball screw drive

Linear Unit	Drive	Line	Support profile cross-section	Dimension of drive
Linear Unit	KGT	6	60	P20

KGT = Ball Screw Unit                      P20 = Spindle lead 20 mm

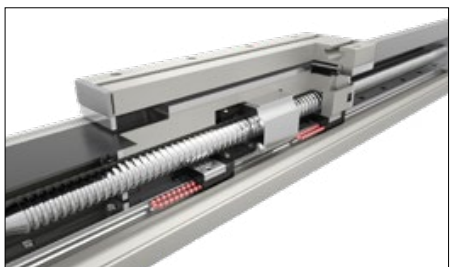

Linear Unit	Designation (T-slot slider – GSF)	Line	Support profile cross-section	Drive
<b>Timing-belt drive</b>				
Linear Unit	GSF	8	40	R10

Linear Unit	Designation (compact Linear Unit – KLE)	Line	Support profile cross-section (height x width)	Guide technology (roller guide)
<b>Timing-belt drive</b>				
Linear Unit	KLE	6	60x60	LR
Linear Unit	KLE	8	80x80	LR

Linear Unit	Designation (criss-crossed roller guide – KRF)	Line	Support profile cross-section (height x width)	Drive	Drive side
<b>Timing-belt drive</b>					
Linear Unit	KRF	8	80x40	ZR	Left
Linear Unit	KRF	8	80x40	ZR	Right
Linear Unit	KRF	8	80x40	ZR	Synchronous

Linear Unit	Designation (roller guide – LRE)	Line	Guiding shaft diameter	Support profile cross-section (height x width)	Drive	Dimension of drive
<b>Timing-belt drive</b>						
Linear Unit	LRE	5	D6	60x20	ZU	40 R10
Linear Unit	LRE	8	D10	80x40	ZU	40 R25
Linear Unit	LRE	8	D10	80x80	ZU	40 R25
Linear Unit	LRE	8	D14	80x40	ZU	40 R25
Linear Unit	LRE	8	D14	80x40	ZU	80 R25
Linear Unit	LRE	8	D14	80x80	ZU	40 R25
Linear Unit	LRE	8	D14	80x80	ZU	80 R25
Linear Unit	LRE	8	D14	120x80	ZU	40 R25
Linear Unit	LRE	8	D14	120x80	ZU	80 R25
Linear Unit	LRE	8	D25	120x80	ZU	80 R25
Linear Unit	LRE	8	D25	120x80	ZU	80 R50
Linear Unit	LRE	8	D25	200x80	ZU	80 R25
Linear Unit	LRE	8	D25	200x80	ZU	80 R50

<b>Ball screw drive</b>						
Linear Unit	LRE	8	D10	80x80	KGT	20x5
Linear Unit	LRE	8	D10	80x80	KGT	20x20
Linear Unit	LRE	8	D14	80x80	KGT	20x5
Linear Unit	LRE	8	D14	80x80	KGT	20x20
Linear Unit		6		60x60	KGT	P20

<b>Chain drive</b>						
Linear Unit	LRE	8	D14	80x40	KU	80

<b>Rack drive</b>						
Linear Unit	LRE	8	D10	80x40	ZS K	
Linear Unit	LRE	8	D14	80x40	ZS	

ZR = Timing Belt    ZU = Timing-Belt Reverse Unit    KGT = Ball Screw Unit    KU = Chain Reverse Unit    ZS = Rack    ZS K = Rack, plastic



## Nomenclature for plug 'n' play Drive Sets

Drive set	Linear Unit	Drive type	Drive size
Drive set	GSF 8 40	AP/WP	40
Drive set	KLE 6 60x60	AP/WP	40
Drive set	KLE 6 60x60	AP/WP	60
Drive set	KLE 8 80x80	AP/WP	60
Drive set	KLE 8 80x80	AP/WP	80
Drive set	KRF 8 ZR	AP/WP	60
Drive set	KRF 8 ZR	AP/WP	80
Drive set	ZU 5 40 D30/D12	AP/WP	40
Drive set	ZU 8 80 D55/D34	AP/WP	60
Drive set	ZU 8 80 D55/D34	AP/WP	80
Drive set	ZU 8 80 D80/D34	AP/WP	80
Drive set	8 D40/D15	AP/WP	60
Drive set	KGT D40/D15	SE	60
Drive set	KGT 6 60	SE	40
Drive set	KGT 6 60	SE	60
Drive set	KGT D40/D15	SE	80
Drive set	Rack 8	AP/WP	60
Drive set	Rack 8	AP/WP	80

SE = Servomotor

WP = Bevel planetary Gearbox

AP = Axial planetary Gearbox

## Nomenclature for Gearboxes

Name	Type	Size	Gear ratio [1 : n]
Gearbox	AP	40	3
			5
			7
	WP	60	3
			5
			7
		80	16
			3
			5
			7

WP = Bevel planetary Gearbox

AP = Axial planetary Gearbox

## Nomenclature for Motors

Name	Type	Size [mm]	Stall torque [Nm]	DC bus circuit voltage	Speed [1/100]	Encoder		Brake
Motor	SE	40	0.35	3 (320 V)	90	R	AK	B
		60	1.50	3 (320 V)	60			
		80	3.50	5 (560 V)	55			

SE = Servomotor    R = Resolver    AK = Absolute encoder, capacitive    B = Brake

## Nomenclature for Controllers

Name	Type	Phase	Rated current [A]	
Controller	C	1	02	
			05	
		3	05	
	BL	1	04	/C

C = Controller    BL = Basic Line    /C = Cabinet (control cabinet installation)

## Nomenclature for Cables

Name	Type	Connection	Length [m]
Data Cable		RSC	5
			10
			15
			20
			25
	BL		5
			10
			15

BL = Basic Line

RSC = Resolver-Servomotor-Controller

Name	Type	Connection	Length [m]
Data Cable		AKSC	5
			10
			15
			20
			25
	BL		5
			10
			15

BL = Basic Line

AKSC = Absolute encoder-capacitive servomotor-controller

Name	Type	Connection	Phase	Rated current [A]	Length [m]
Power Cable		SC	1	05	5
					10
					15
					20
					25
				08	5
	10				
	BL		04	5	
				10	
	15				
			3	10	5
					10

BL = Basic Line

SC = Servomotor-Controller

## All Linear Units in comparison

Linear Unit	Art. No.	Max. drive torque [Nm]	Max. speed	Max. acceleration	Repeat accuracy	Travel distance per revolution [mm]	Frictional moment [Nm]	Efficiency [%]
Linear Unit GSF 8 40 R10	0.0.655.98	3	up to 1 m/s	up to 3 m/s <sup>2</sup>	up to 0.5 mm	115	0.1	
Linear Unit KLE 6 60x60 LR	0.0.605.07	12	up to 10 m/s	up to 10 m/s <sup>2</sup>	up to 0.1 mm	155	1	
Linear Unit KLE 8 80x80 LR	0.0.605.02	50	up to 10 m/s	up to 10 m/s <sup>2</sup>	up to 0.1 mm	210	2.5	
Linear Unit KRF 8 80x40 ZR, right-hand input shaft	0.0.648.66	23	up to 10 m/s	up to 10 m/s <sup>2</sup>	up to 0.1 mm	145	2	
Linear Unit KRF 8 80x40 ZR, left-hand input shaft	0.0.641.21	23	up to 10 m/s	up to 10 m/s <sup>2</sup>	up to 0.1 mm	145	2	
Linear Unit KRF 8 80x40 ZR, synchronous drive	0.0.648.69	23	up to 10 m/s	up to 10 m/s <sup>2</sup>	up to 0.1 mm	145	2	
Linear Unit LRE 5 D6 60x20 ZU 40 R10	0.0.666.89	3.3	up to 5 m/s	up to 10 m/s <sup>2</sup>	up to 0.15 mm	140	0.2	
Linear Unit LRE 8 D10 80x40 ZU 40 R25	0.0.662.70	20	up to 10 m/s	up to 10 m/s <sup>2</sup>	up to 0.15 mm	150	0.9	
Linear Unit LRE 8 D10 80x80 ZU 40 R25	0.0.663.32	20	up to 10 m/s	up to 10 m/s <sup>2</sup>	up to 0.15 mm	150	0.9	
Linear Unit LRE 8 D14 80x40 ZU 40 R25	0.0.662.91	20	up to 10 m/s	up to 10 m/s <sup>2</sup>	up to 0.15 mm	150	1	
Linear Unit LRE 8 D14 80x40 ZU 80 R25	0.0.663.12	52	up to 10 m/s	up to 10 m/s <sup>2</sup>	up to 0.15 mm	280	1	
Linear Unit LRE 8 D14 80x80 ZU 40 R25	0.0.663.25	20	up to 10 m/s	up to 10 m/s <sup>2</sup>	up to 0.15 mm	150	1	
Linear Unit LRE 8 D14 80x80 ZU 80 R25	0.0.663.26	52	up to 10 m/s	up to 10 m/s <sup>2</sup>	up to 0.15 mm	280	1	
Linear Unit LRE 8 D14 120x80 ZU 40 R25	0.0.663.34	20	up to 10 m/s	up to 10 m/s <sup>2</sup>	up to 0.15 mm	150	1	
Linear Unit LRE 8 D14 120x80 ZU 80 R25	0.0.663.35	52	up to 10 m/s	up to 10 m/s <sup>2</sup>	up to 0.15 mm	280	1	
Linear Unit LRE 8 D25 120x80 ZU 80 R25	0.0.663.36	52	up to 10 m/s	up to 10 m/s <sup>2</sup>	up to 0.15 mm	280	2.3	
Linear Unit LRE 8 D25 120x80 ZU 80 R50	0.0.666.65	92	up to 10 m/s	up to 10 m/s <sup>2</sup>	up to 0.15 mm	280	3.4	
Linear Unit LRE 8 D25 200x80 ZU 80 R25	0.0.666.53	52	up to 10 m/s	up to 10 m/s <sup>2</sup>	up to 0.15 mm	280	2.3	
Linear Unit LRE 8 D25 200x80 ZU 80 R50	0.0.666.66	92	up to 10 m/s	up to 10 m/s <sup>2</sup>	up to 0.15 mm	280	3.4	
Linear Unit KGT 6 60 P20	0.0.706.00	3.7	up to 1 m/s	up to 15 m/s <sup>2</sup>	up to 0.01 mm	20	0.2	90
Linear Unit LRE 8 D10 80x80 KGT 20x5	0.0.668.12	2	up to 0.25 m/s	up to 5 m/s <sup>2</sup>	up to 0.05 mm	5		80
Linear Unit LRE 8 D10 80x80 KGT 20x20	0.0.668.10	7.5	up to 1 m/s	up to 5 m/s <sup>2</sup>	up to 0.05 mm	20		85
Linear Unit LRE 8 D14 80x80 KGT 20x5	0.0.668.06	2	up to 1 m/s	up to 5 m/s <sup>2</sup>	up to 0.05 mm	5		80
Linear Unit LRE 8 D14 80x80 KGT 20x20	0.0.668.08	7.5	up to 1 m/s	up to 5 m/s <sup>2</sup>	up to 0.05 mm	20		85
Linear Unit LRE 8 D14 80x40 KU 80	0.0.664.54	20	up to 2 m/s	up to 5 m/s <sup>2</sup>	up to 0.5 mm	203.2	1	
Linear Unit LRE 8 D14 80x40 ZS	0.0.664.28	23	up to 3 m/s	up to 5 m/s <sup>2</sup>	up to 0.1 mm	144	1	
Linear Unit LRE 8 D10 80x40 ZS K light	0.0.679.91	8	up to 3 m/s	up to 5 m/s <sup>2</sup>	up to 0.5 mm	144	0.9	

Mx max [Nm]	My max [Nm]	Mz max [Nm]	Operating load Fx max [N]	Fy max [N]	Fz max [N]	Max. stroke [mm]	Mass 0 stroke [kg]	
0.4	2	1.25	150	25	50	3860	1.1	21
20	50	75	500	750	500	5750	4.0	23
50	100	150	1500	1500	1000	5600	9.8	24
50	140	140	1000	2500	2500	5760	5.1	26
50	140	140	1000	2500	2500	5760	5.1	26
50	140	140	1000	2500	2500	5760	5.0	27
4	6	8	150	400	320	2828	1.2	29
22	35	52	870	1300	880	5760	6.7	31
39	35	52	870	1300	880	5760	7.8	32
40	64	96	870	2400	1600	5760	8.4	34
40	64	96	1200	2400	1600	5820	11.7	35
76	64	96	870	2400	1600	5760	9.4	36
76	64	96	1200	2400	1600	5820	12.6	37
76	64	96	870	2400	1600	5760	10.3	38
76	64	96	1200	2400	1600	5820	13.2	39
301	520	760	1200	7600	5200	5620	31.1	41
301	520	760	2100	7600	5200	5620	32.6	42
301	520	760	1200	7600	5200	5620	32.8	43
301	520	760	2100	7600	5200	5620	34.4	44
15	120	120	1000	2000	2000	2600	3.2	47
39	35	52	2000	1300	880	2687	8.3	49
39	35	52	2000	1300	880	2687	8.2	50
76	64	96	2000	2400	1600	2687	10.0	52
76	64	96	2000	2400	1600	2687	10.0	53
40	64	96	620	2400	1600	5760	7.7	56
40	64	96	1000	2400	1600	5678	7.4	61
22	35	52	350	1300	880	5678	5.1	59

## Calculating service life

Service life coefficient  $k_L$  can be used to calculate the approximate anticipated service life of the guide. The table below can be used to match values for  $k_L$  to an anticipated service life  $L$  [km]. Please note that these are theoretical values and that additional operating factors are not included in calculations of this type. For example, if the products are subjected to impact loads or are used in contaminated environments, their anticipated service life can be considerably reduced. Values above 1.5 are not permitted for  $k_L$  and are purely theoretical in nature.

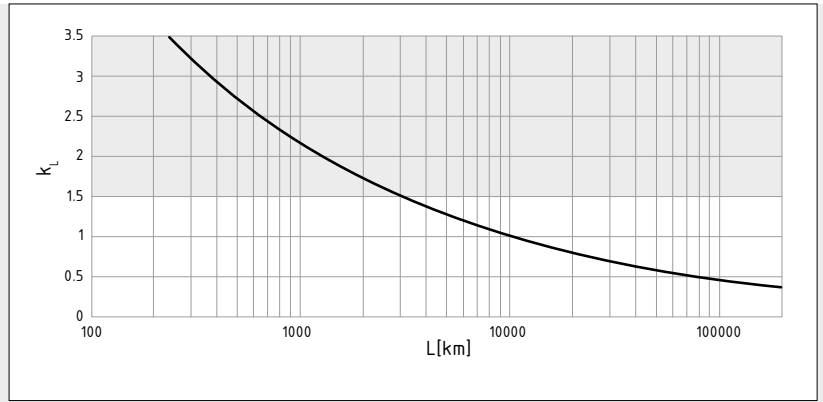

$$k_L = \frac{|M_x|}{M_{x \max}} + \frac{|M_y|}{M_{y \max}} + \frac{|M_z|}{M_{z \max}} + \frac{|F_y|}{F_{y \max}} + \frac{|F_z|}{F_{z \max}}$$

## Travel speed v in relation to input speed n (timing-belt drive)

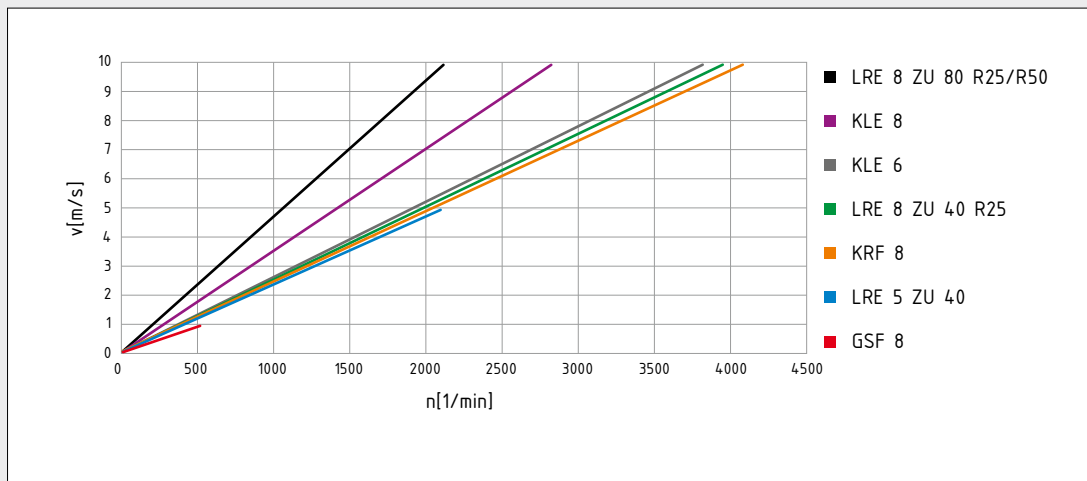

## Travel speed v in relation to input speed n (ball screw, chain and rack drives)

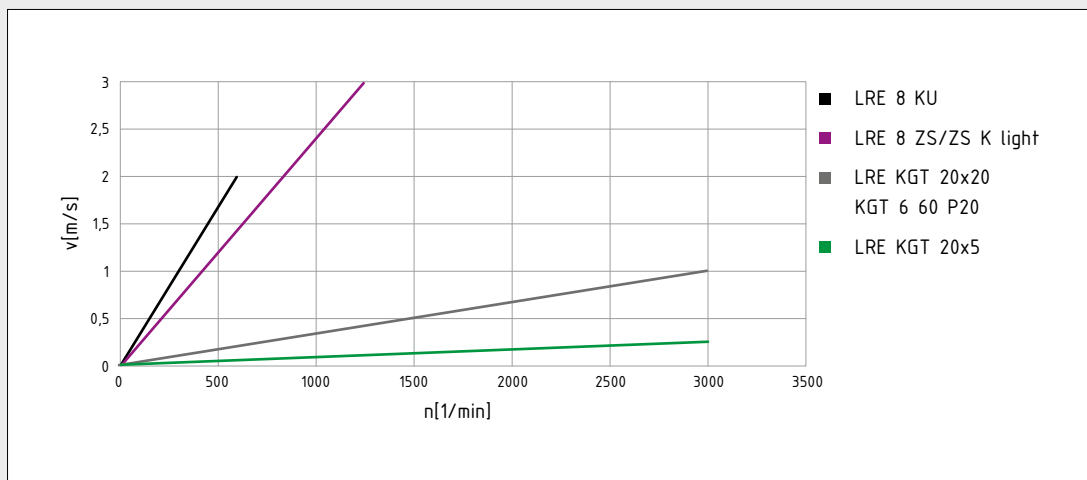

### Operational force $F_x$ dependent on input torque $M$ (timing-belt drives $F_x > 500\text{N}$ )

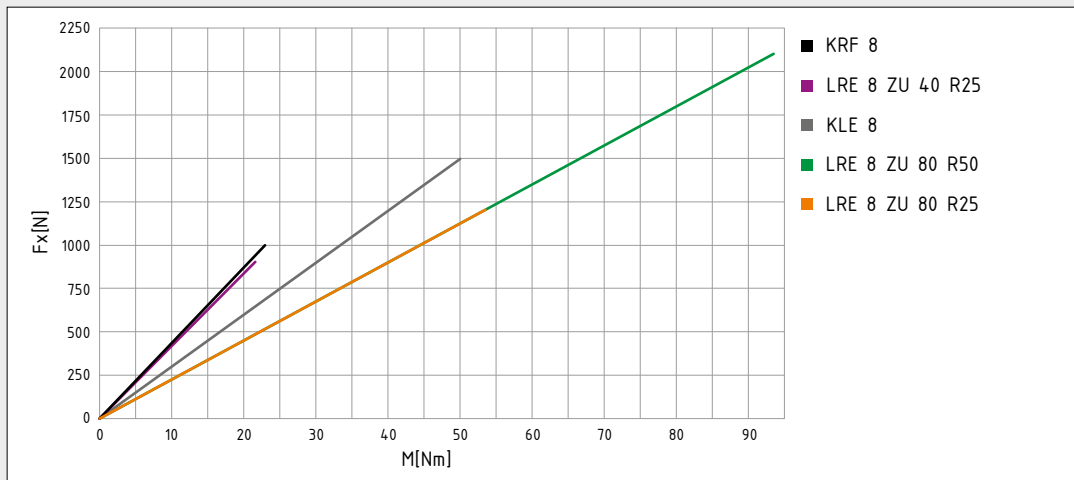

### Operational force $F_x$ dependent on input torque $M$ (timing-belt drives $F_x \leq 500\text{N}$ )

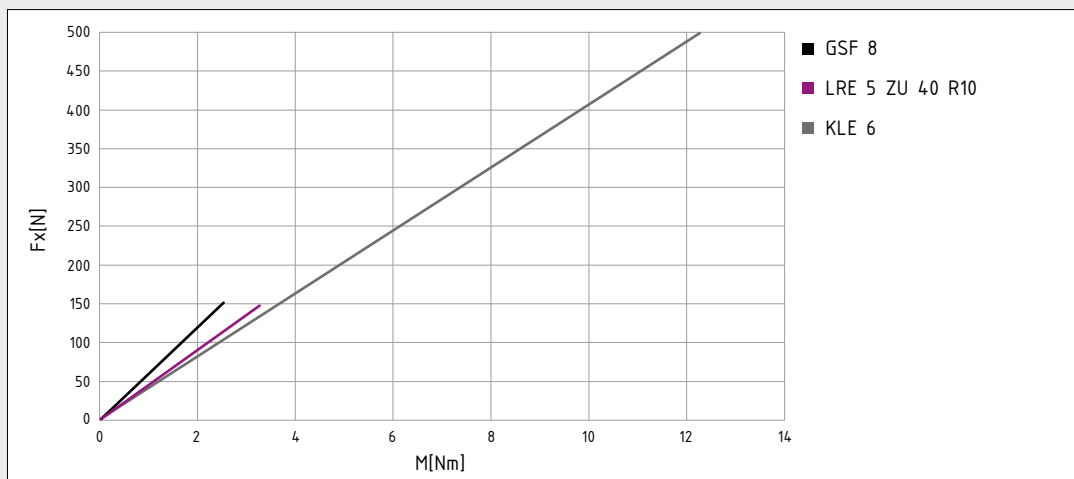

### Operational force $F_x$ dependent on input torque $M$ (ball screw drive, chain drive, rack drive)

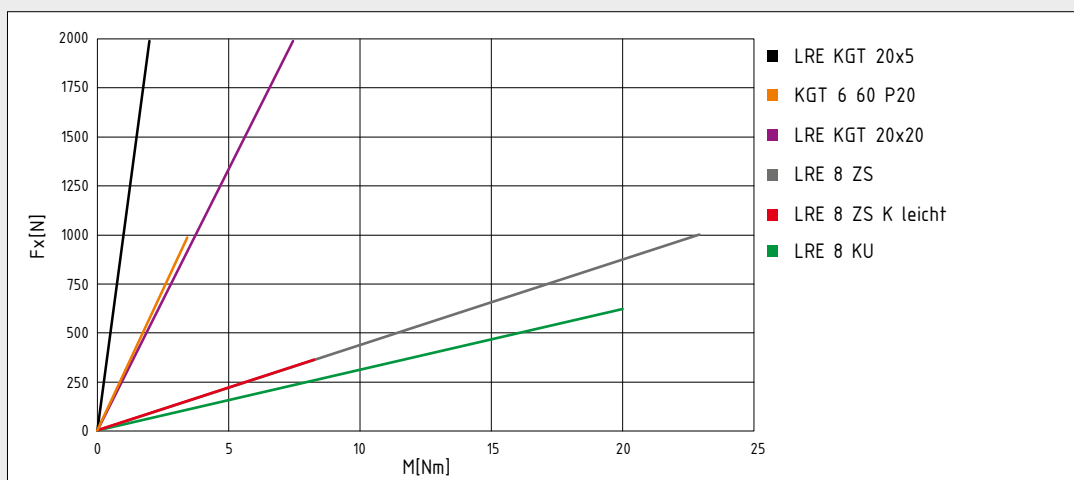



## Maximum possible acceleration in relation to moved mass and installation orientation

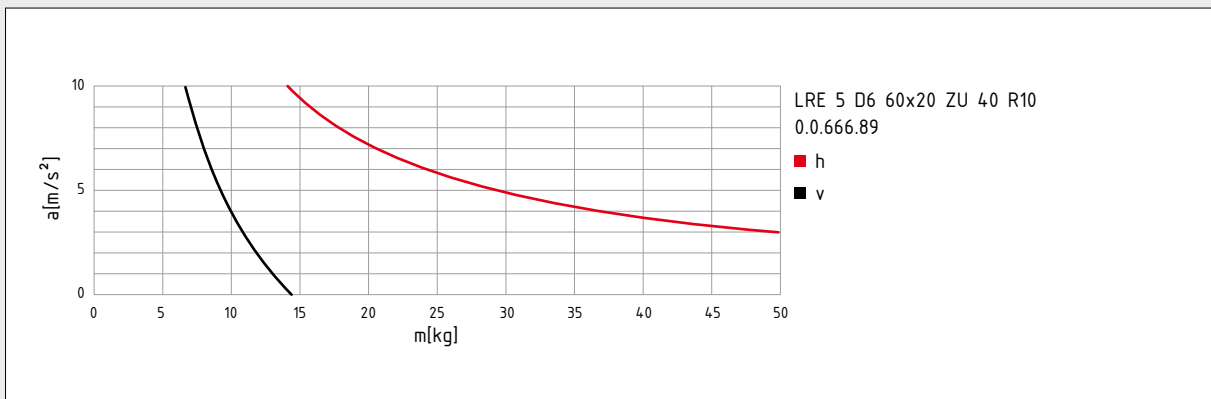
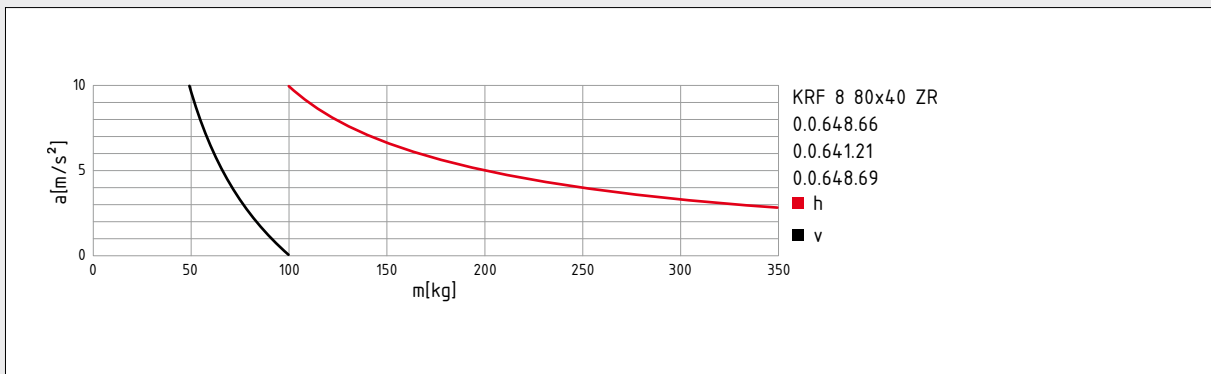
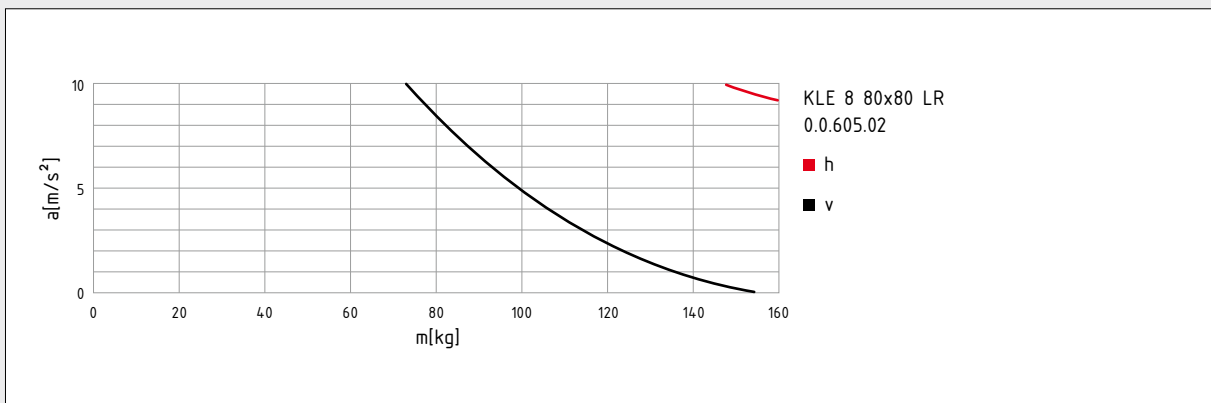
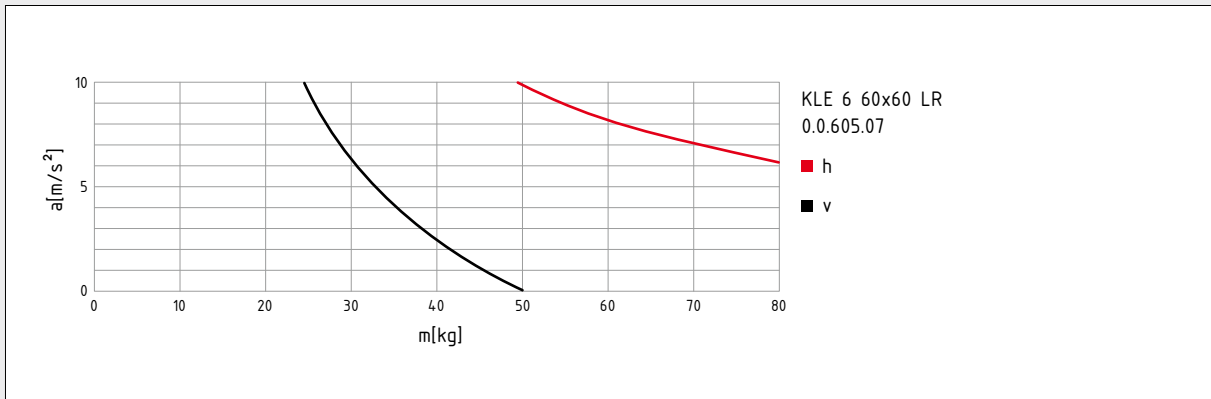

h = horizontal orientation    v = vertical orientation

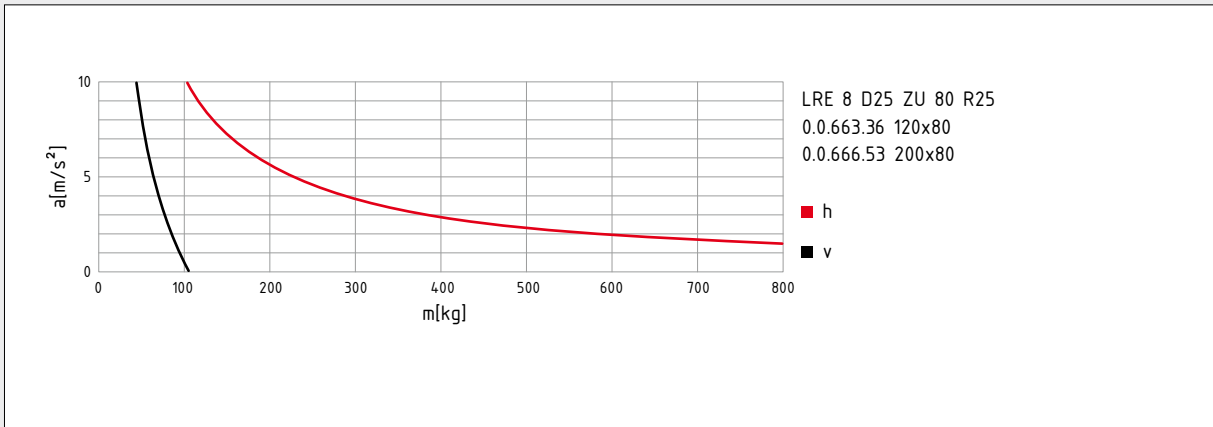
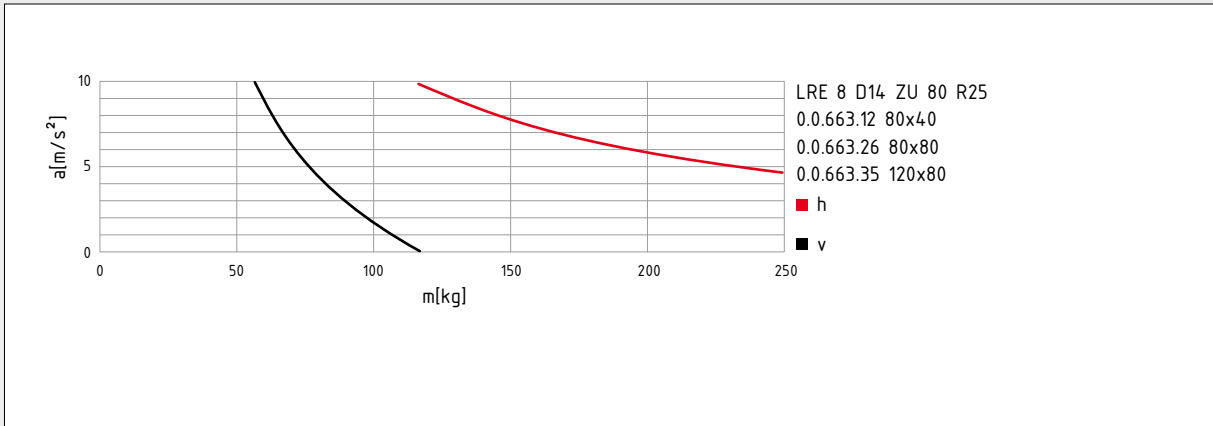
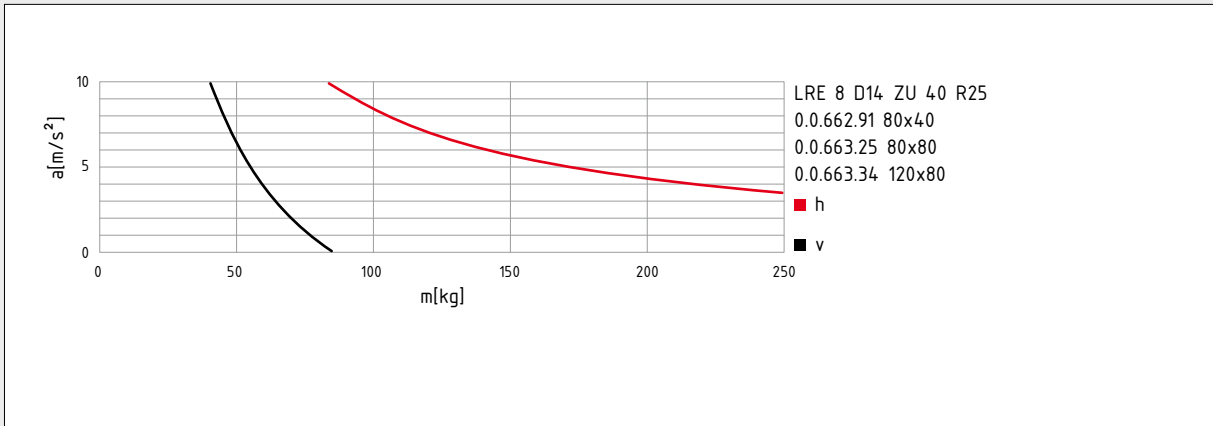
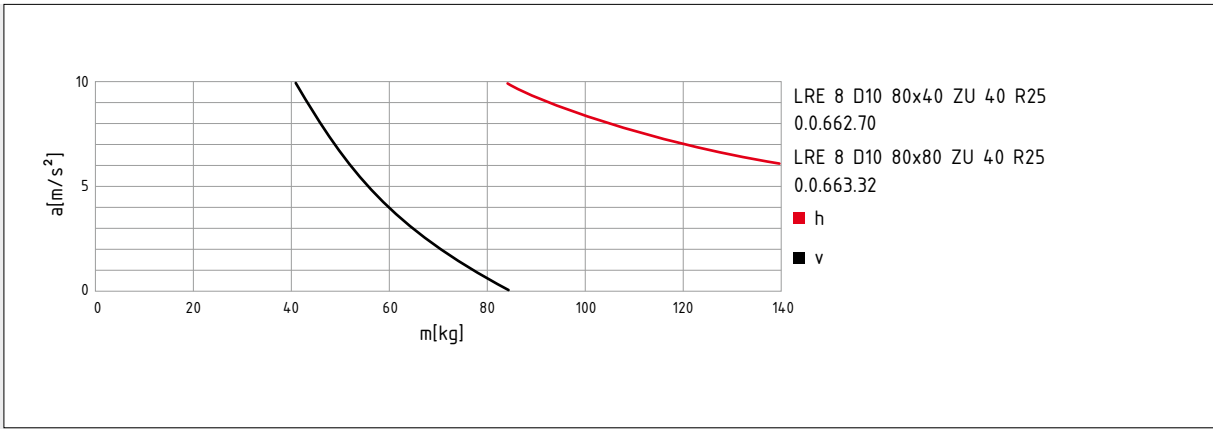

h = horizontal orientation    v = vertical orientation

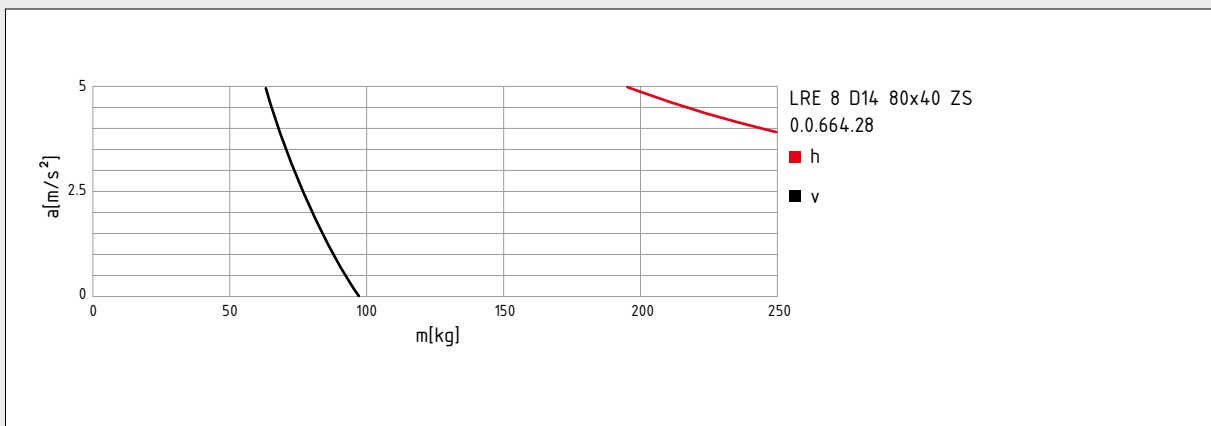
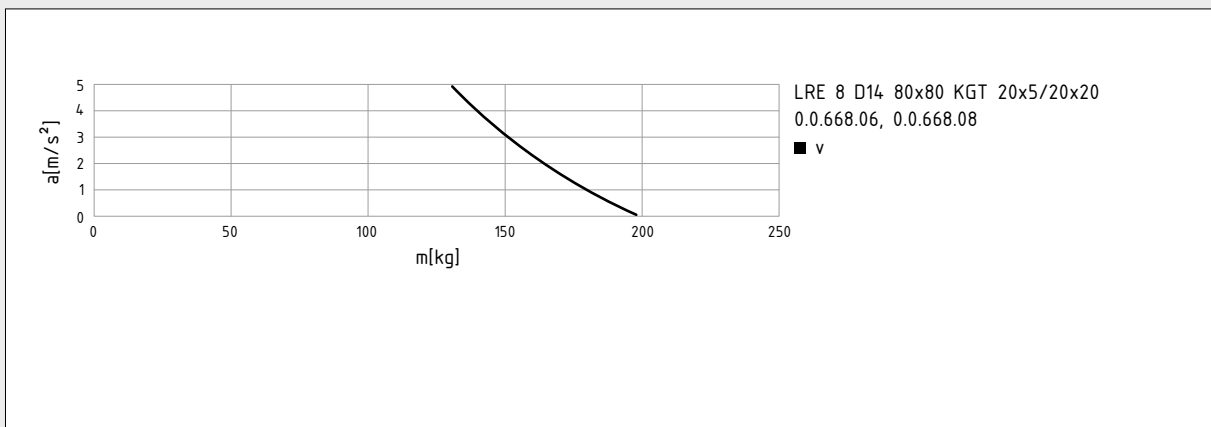
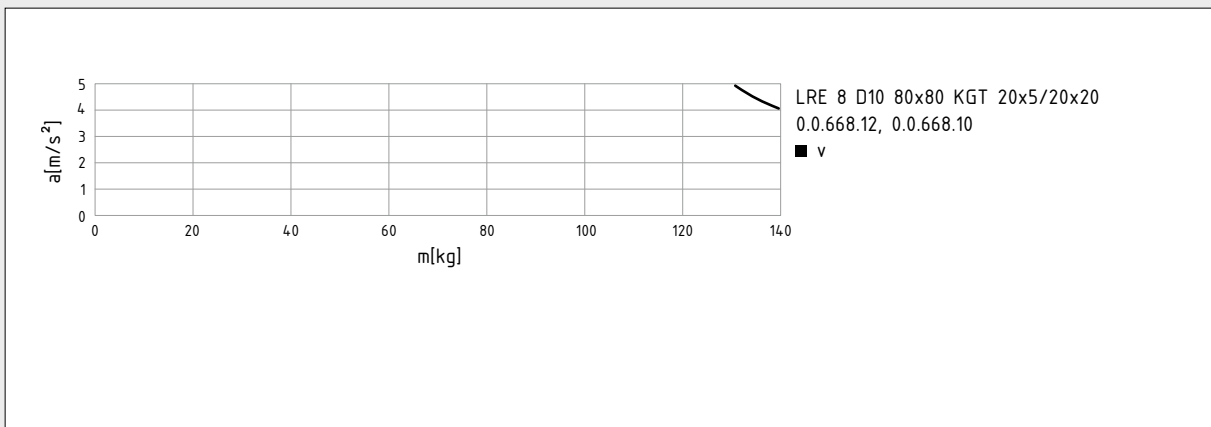
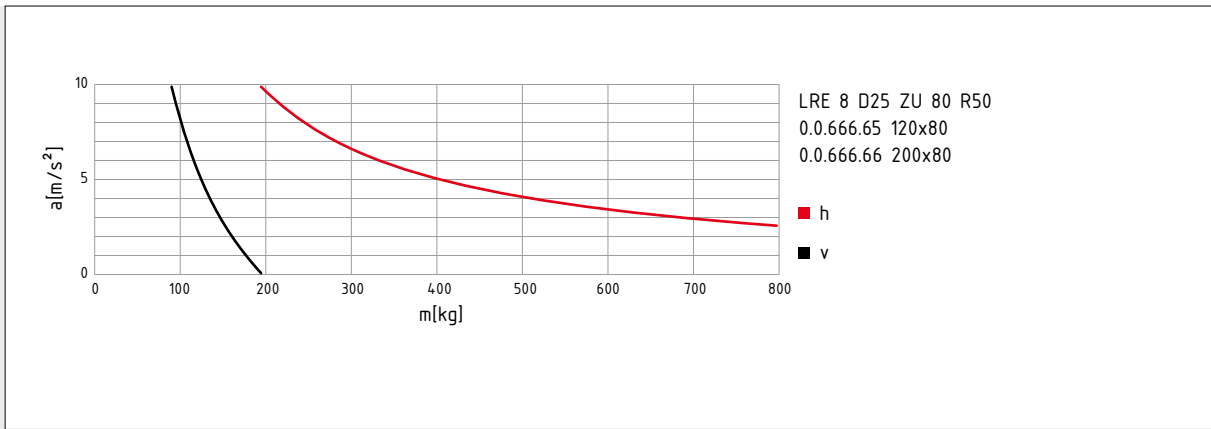

h = horizontal orientation    v = vertical orientation

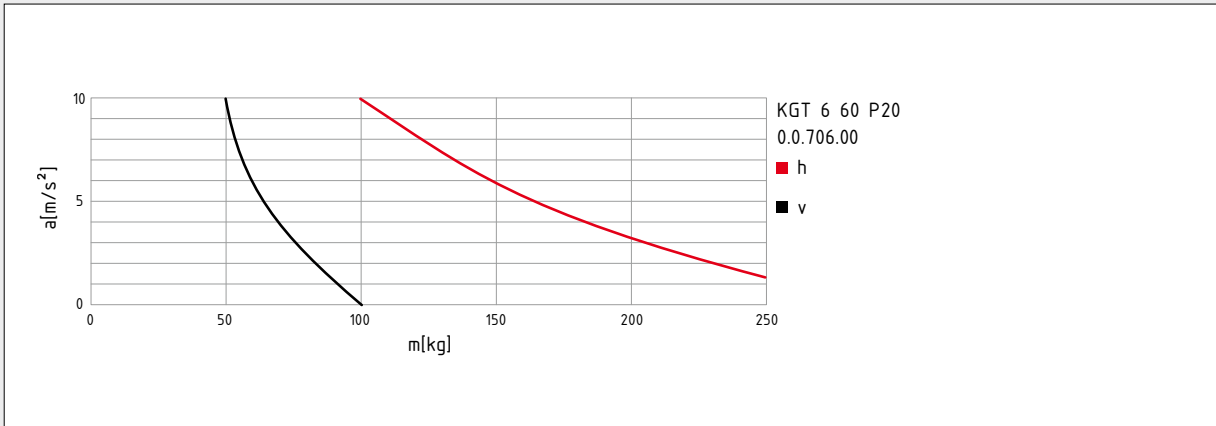
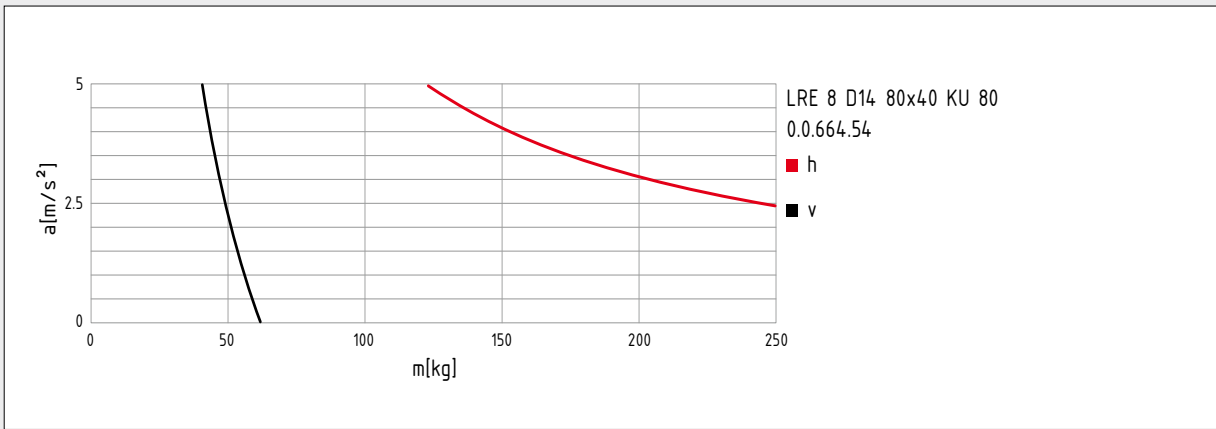
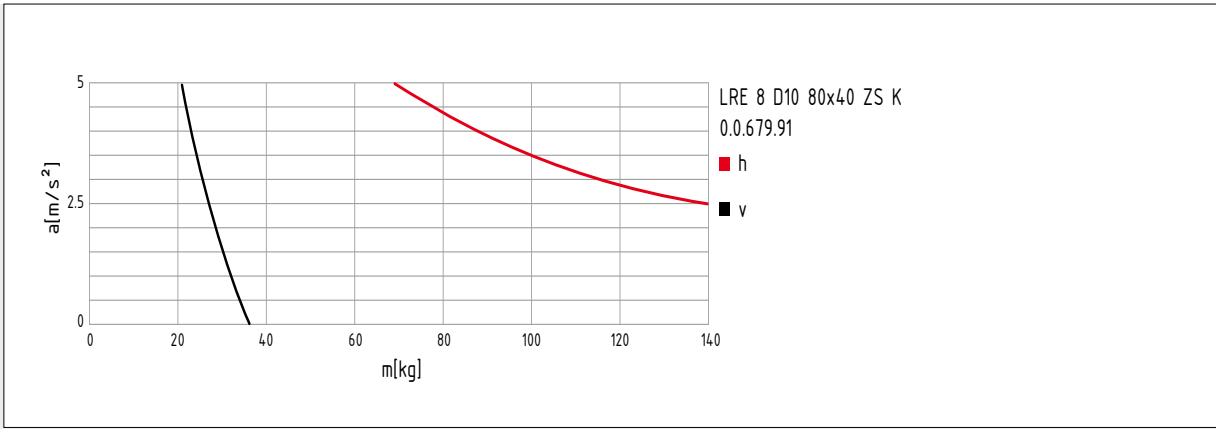

h = horizontal orientation    v = vertical orientation

## Permissible synchroniser shaft speed in relation to length

0.0.609.86 Tube D20x3 St

D = speed [RPM]  
L = length of shaft [mm]

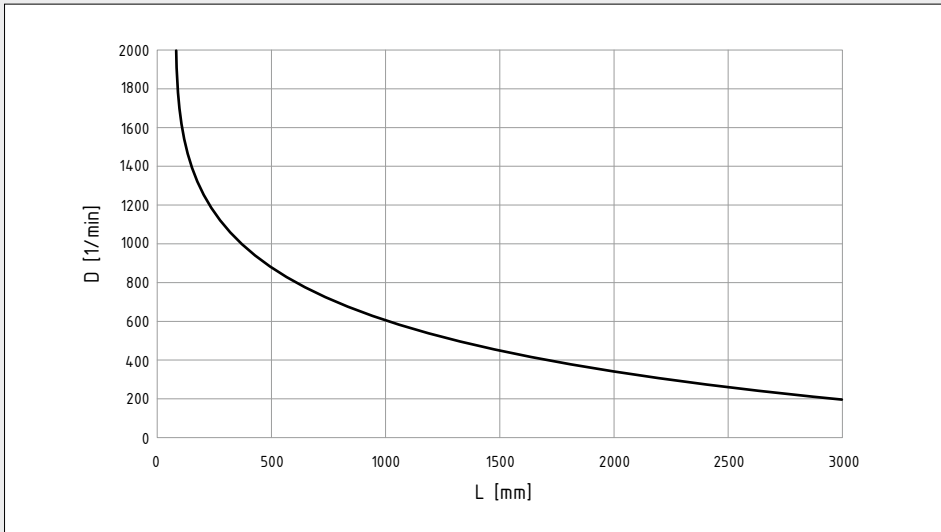

0.0.664.14 Tube D16x1.5 St

D = speed [RPM]  
L = length of shaft [mm]

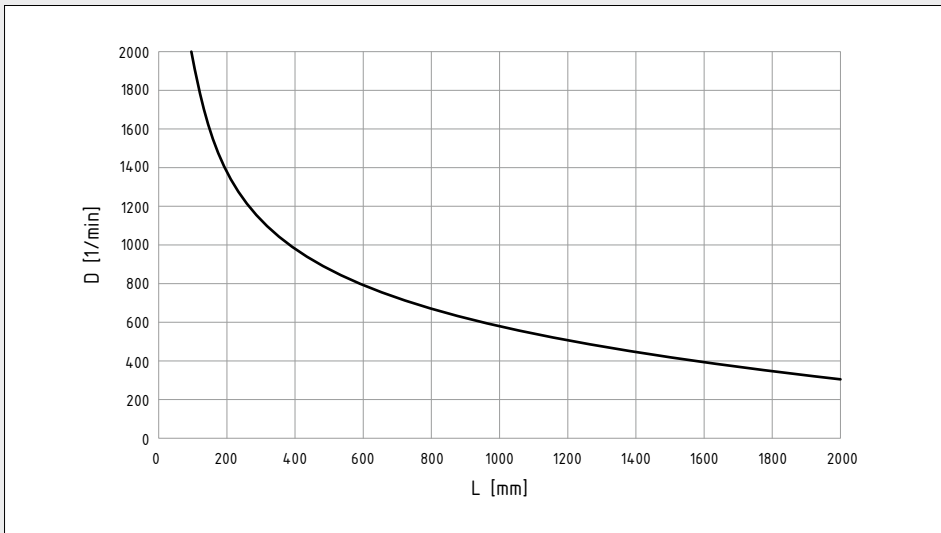

0.0.609.83 Tube D25x3 St

D = speed [RPM]  
L = length of shaft [mm]

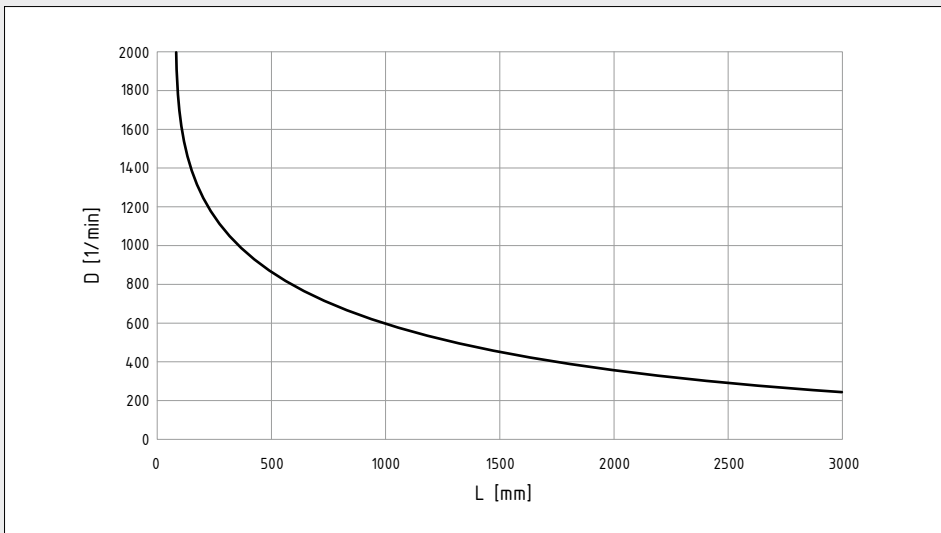

0.0.463.56 Synchronising Shaft Profile VK32

D = speed [RPM]

L = length of shaft [mm]

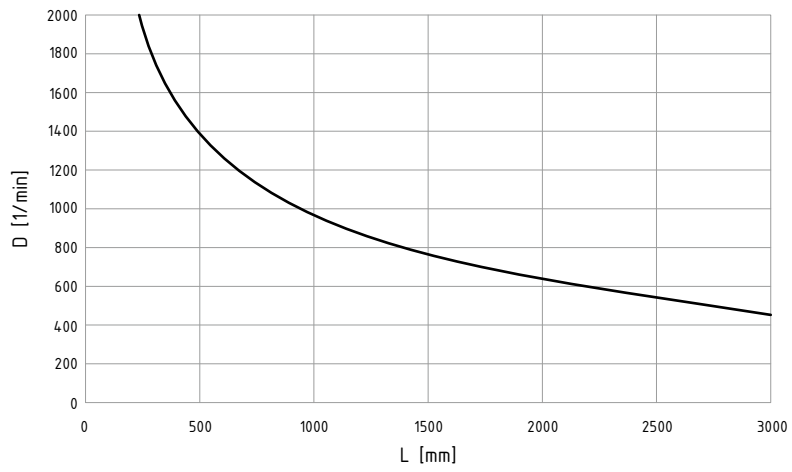

## Information about installing couplings

To prevent axial forces between the drive and the Linear Unit when using two-part couplings, it is crucial that the coupling halves are precisely aligned. The coupling half on the Linear Unit side should be fitted flush. The coupling half on the motor side must be installed so as to comply with dimension x, the distance between the Linear Unit and the bottom of the motor-side coupling half.

a = Linear Unit

b = Coupling half

c = Transmission/motor

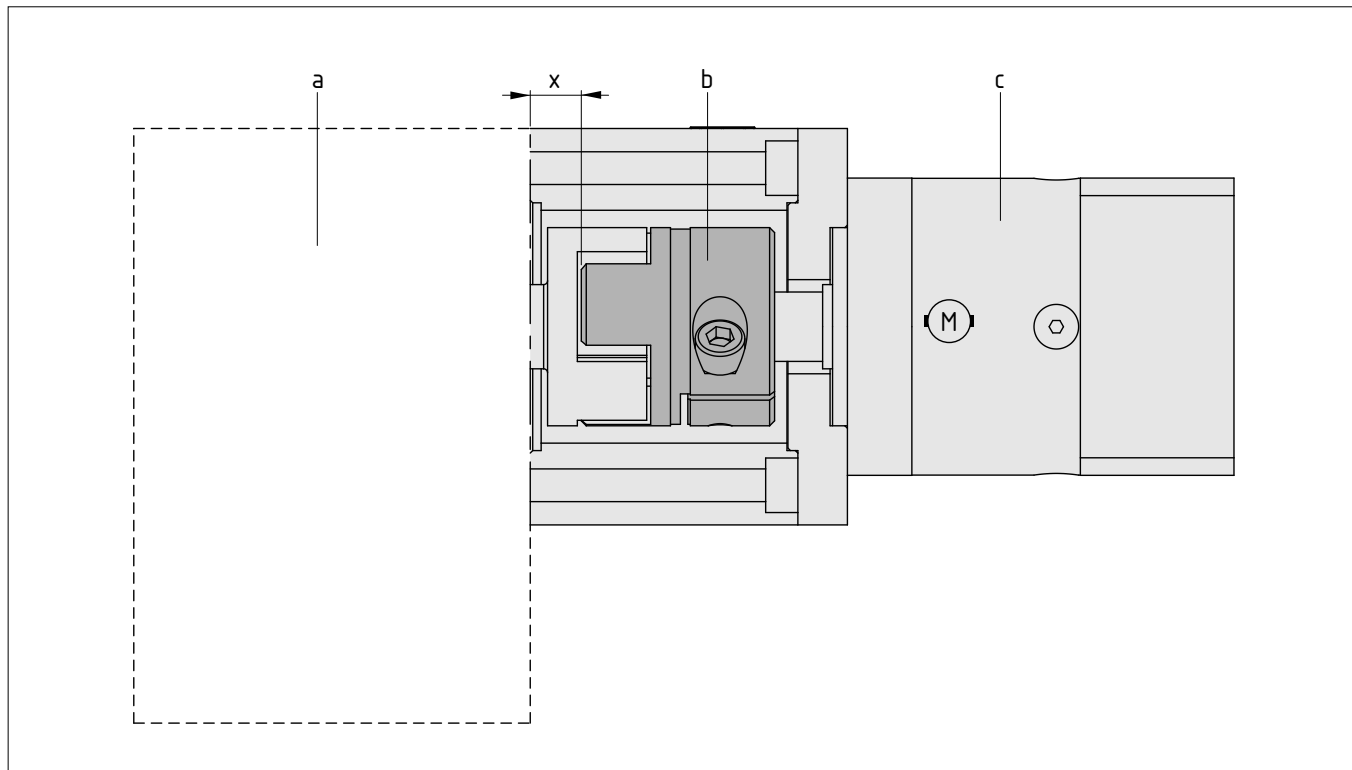

Universal Drive Set	Art. No.	x [mm]
Drive Set 5 40 D30/D12	0.0.662.49	9.9 - 10.9
Drive Set 8 40 D40/D15	0.0.668.02	10.3 - 11.3
Drive Set 8 80 D55/D34	0.0.668.03	15.6 - 16.6
Drive Set 8 80 D80/D34	0.0.668.04	22.5 - 23.5
Drive Set KLE 6 60x60	0.0.609.80	15.0 - 16.0
Drive Set KLE 8 80x80	0.0.609.77	16.0 - 17.0
Drive Set KGT D40/D15	0.0.667.76	22.3 - 23.3
Drive Set GSF 8 40	0.0.654.23	7.7 - 8.7
Rack 8 Coupling Module	0.0.621.73	32.8 - 33.8
Drive Set KGT 6 60	0.0.704.53	14.7 - 15.7

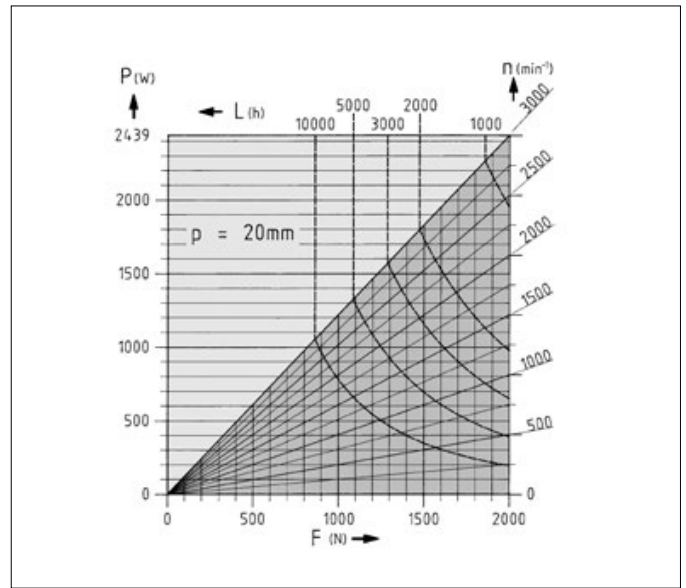
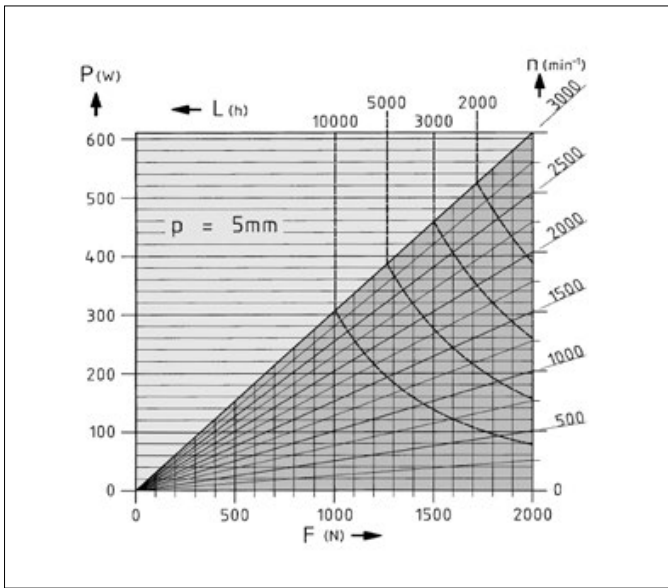

The service life of the screw and drive nut combination can be calculated based on the thrust load and drive speeds

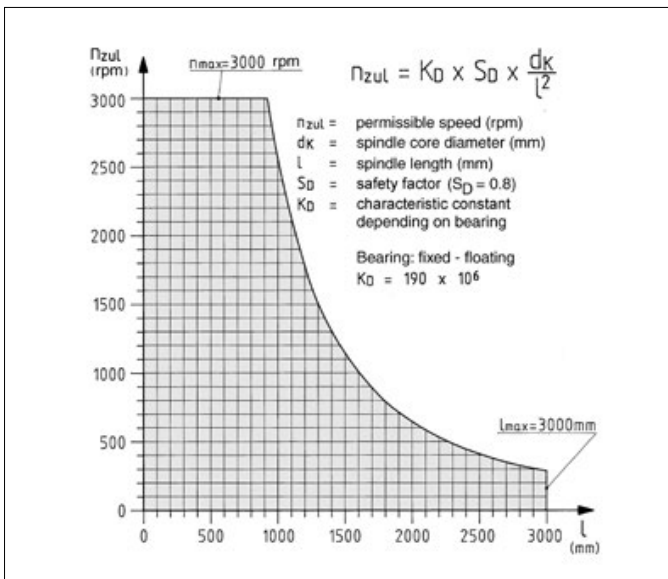

The maximum travelling speed of the spindle units depends on the length of the spindle (see adjacent diagram).

Calculating the feed rate of the carriage based on the drive speed at the input of the KGT:

$$v = \frac{n \cdot p}{60000}$$

$$v \left[ \frac{m}{s} \right] = \text{Feed rate}$$

$$n \left[ \frac{1}{min} \right] = \text{Drive speed}$$

$$p \text{ [mm]} = \text{Spindle lead}$$

Calculating the feed force of the carriage based on the drive torque at the input of the KGT:

$$F = \frac{M \cdot \pi \cdot \eta}{p} \cdot 2000$$

$$F \text{ [N]} = \text{Feed force}$$

$$M \text{ [Nm]} = \text{Drive torque}$$

$$\eta \text{ [ ]} = \text{Efficiency (KGT 20x5: 0.8; KGT 20x20: 0.85; KGT 6 60 P20: 0.9)}$$

$$p \text{ [mm]} = \text{Spindle lead}$$

Linear Unit	Art. No.	Spindle-core diameter $d_k$ [mm]
Linear Unit KGT 6 60 P20	0.0.706.00	13.0
Linear Unit LRE 8 D10 80x80 KGT 20x5	0.0.668.12	16.9
Linear Unit LRE 8 D14 80x80 KGT 20x5	0.0.668.06	
Linear Unit LRE 8 D10 80x80 KGT 20x20	0.0.668.10	
Linear Unit LRE 8 D14 80x80 KGT 20x20	0.0.668.08	



## Transferable torques depend on the clamping diameter

		Art. No.	0.0.654.23	0.0.662.49	0.0.704.53	0.0.609.80	0.0.668.02
		Product name	Drive Set GSF 8 40	Drive Set 5 40 D30/D12	Drive Set KGT 6 60	Drive Set KLE 6 60x60	Drive Set 8 40 D40/D15
		Maximum torque, output side [Nm]	8			34	40
		Maximum torque, elastomer [Nm]	4			26	
		Coupling half reborable on drive side up to [mm]	16			20	
Bore diameter, drive side [mm]	7	Maximum torque, drive side [Nm]  (Values in brackets: Maximum torque of combination)	5 (4)				
	8		5.1 (4)			25	
	10		5.3 (4)			27 (26)	
	11		5.6 (4)			27 (26)	
	12		5.8 (4)				
	14		6.1 (4)			29 (26)	
	15		6.3 (4)			30 (26)	
	16		6.5 (4)			31 (26)	
	18					32 (26)	
	19					32 (26)	
	20					34 (26)	
	22						
	24						
	25						
	28						
	30						
	32						
	35						
38							
40							
42							
45							

0.0.667.76	0.0.621.73	0.0.609.77	0.0.668.03	0.0.627.46	0.0.668.04
Drive Set KGT D40/D15	Rack 8 Coupling Module	Drive Set KLE 8 80x80	Drive Set 8 80 D55/D34	Drive Set KRF 8 ZR	Drive Set 8 80 D80/D34
40	50		116	60	116
26				-	325
20		28		25	45
25					
27 (26)		34			
27 (26)		35			
				60	
29 (26)		36		60	
30 (26)		38		60	92
31 (26)		38		60	94
32 (26)		39		60	97
32 (26)		40		60	98
34 (26)		41		60	99
		42		60	102
		43		60	104
		45		60	105
		46			109
					112
					113
					118 (116)
					122 (116)
					123 (116)
					126 (116)
					130 (116)

## Overview of Gearboxes

### Gearboxes AP

Art. No.	0.0.666.05	0.0.666.06	0.0.666.07	0.0.666.11
Product name	Gearbox AP 40-3	Gearbox AP 40-5	Gearbox AP 40-7	Gearbox AP 60-3
Efficiency	0.98	0.98	0.97	0.98
Gear ratio i	3	5	7	3
Rated output torque [Nm]	11	14	8.5	28
Max. mechanical input speed [1/min]	18000			
Mass moment of inertia [kg cm <sup>2</sup> ]	0.027	0.019	0.015	0.149
Torsional rigidity [Nm/arcmin]	1	1	0.9	2.3
Standard backlash	< 15			
Tightening torque for clamping hub screw [Nm]	2			
Type				
Operating temperature				
Protection class				

### Gearboxes WP

Art. No.	0.0.666.08	0.0.666.09	0.0.666.10	0.0.666.14
Product name	Gearbox WP 40-3	Gearbox WP 40-5	Gearbox WP 40-7	Gearbox WP 60-3
Efficiency	0.94	0.94	0.94	0.95
Gear ratio i	3	5	7	3
Rated output torque [Nm]	3.96	6.6	7.48	12.32
Max. mechanical input speed [1/min]	18000			
Mass moment of inertia [kg cm <sup>2</sup> ]	0.049	0.035	0.033	0.394
Torsional rigidity [Nm/arcmin]	0.8	0.8	0.7	2
Standard backlash	< 21			
Tightening torque for clamping hub screw [Nm]	2			
Type				
Operating temperature				
Protection class				

0.0.666.12	0.0.666.13	0.0.698.04	0.0.666.17	0.0.666.18	0.0.666.19
Gearbox AP 60-5	Gearbox AP 60-7	Gearbox AP 60-16	Gearbox AP 80-3	Gearbox AP 80-5	Gearbox AP 80-7
0.98	0.97	0.96	0.98	0.98	0.97
5	7	16	3	5	7
40	25	44	85	110	65
13000			7000		
0.1	0.09	0.106	0.654	0.423	0.379
2.2	2.1	2.8	5.7	5.5	5.2
< 10			< 7		
4.5			9.5		
Planetary gearbox, inline					
-25 °C to 90 °C					
IP 54					

0.0.666.15	0.0.666.16	0.0.698.05	0.0.666.20	0.0.666.21	0.0.666.22
Gearbox WP 60-5	Gearbox WP 60-7	Gearbox WP 60-16	Gearbox WP 80-3	Gearbox WP 80-5	Gearbox WP 80-7
0.95	0.94	0.93	0.96	0.95	0.95
5	7	16	3	5	7
21.12	22	38.72	35.2	58.96	57.2
13000		13000	7000		
0.257	0.245	0.27	1.409	1.017	0.948
1.9	1.8	2	5	4.8	4.8
< 16		< 18	< 13		
4.5			9.5		
Planetary gearbox, right angle					
-25 °C to 90 °C					
IP 54					

## Overview of Motors

Art. No.	0.0.666.03	0.0.666.04	0.0.666.02	0.0.665.99
Product name	Motor SE 40-035-3-90-R	Motor SE 40-035-3-90-R-B	Motor SE 60-150-3-60-R	Motor SE 60-150-3-60-R-B
Rated speed [RPM]	9000	9000	6000	6000
Number of pole pairs	2	2	3	3
DC bus circuit voltage	320	320	320	320
Rated voltage [V]	132	132	180	180
Rated power [W]	200	200	550	550
Rated torque of Motor [Nm]	0.21	0.21	0.9	0.9
Stall torque of motor [Nm]	0.35	0.35	1.5	1.5
Rated current per phase [A]	1.2	1.2	2.2	2.2
Peak torque [Nm]	1.4	1.4	6	6
Peak current [A]	6.4	6.4	13.2	13.2
Max. speed [RPM]	10000	10000	7350	7350
Voltage constant at 1000 RPM [V]	13.2	13.2	27.9	27.9
Torque constant [Nm/A]	0.22	0.22	0.46	0.46
Mass moment of inertia, rotor [kgcm <sup>2</sup> ]	0.054	0.054	0.413	0.413
Holding brake	No	Yes	No	Yes
		0.4		2
Motor type	Permanent-magnet three-phase synchronous servomotor			
Ambient temperature (during operation)	-10°C to +40°C			
Storage temperature	-20°C to +70°C			
Humidity	Less than 90% relative humidity (without condensing)			
Insulation class	F (= up to 155°C) Delta T = 115 K			
Protection class	IP 65			
Max. installation height	4,000 m over NN; with power reduction of 1% per 100 m starting from 1,000 m			
Property	white aluminium, similar to RAL 9006			
Shaft end	Cylindrical shaft end			
Magnetic material	Neodymium iron boron (NdFeB)			
Encoder systems	Resolver			
Approvals	CE, UL			

Art. No.	0.0.688.47	0.0.688.48	0.0.688.49	0.0.688.50	0.0.688.51	0.0.688.52
Product name	Motor SE 40-035-3-90-AK	Motor SE 40-035-3-90-AK-B	Motor SE 60-150-3-60-AK	Motor SE 60-150-3-60-AK-B	Motor SE 80-350-5-55-AK	Motor SE 80-350-5-55-AK-B
Rated speed [RPM]	6000	6000	6000	6000	5500	5500
Number of pole pairs	2	2	3	3	3	3
DC bus circuit voltage	320	320	320	320	560	560
Rated voltage [V]	132	132	180	180	316	316
Rated power [W]	200	200	550	550	1200	1200
Rated torque of Motor [Nm]	0.21	0.21	0.9	0.9	2.1	2.1
Stall torque of motor [Nm]	0.35	0.35	1.5	1.5	3.5	3.5
Rated current per phase [A]	1.2	1.2	2.2	2.2	2.8	2.8
Peak torque [Nm]	1.4	1.4	6	6	14	14
Peak current [A]	6.4	6.4	13.2	13.2	15.6	15.6
Max. speed [RPM]	6000	6000	6000	6000	6000	6000
Voltage constant at 1000 RPM [V]	13.2	13.2	27.9	27.9	55	55
Torque constant [Nm/A]	0.22	0.22	0.46	0.46	0.91	0.91
Mass moment of inertia, rotor [kgcm <sup>2</sup> ]	0.054	0.054	0.413	0.413	1.93	1.93
Holding brake	No	Yes	No	Yes	No	Yes
		0.4		2		4.5
Motor type	Permanent-magnet three-phase synchronous servomotor					
Ambient temperature (during operation)	-10°C to +40°C					
Storage temperature	-20°C to +70°C					
Humidity	Less than 90% relative humidity (without condensing)					
Insulation class	F (= up to 155°C) Delta T = 115 K					
Protection class	IP 65					
Max. installation height	4,000 m over NN; with power reduction of 1% per 100 m starting from 1,000 m					
Property	white aluminium, similar to RAL 9006					
Shaft end	Cylindrical shaft end					
Magnetic material	Neodymium iron boron (NdFeB)					
Encoder systems	Absolute encoder, capacitive					
Approvals	CE, UL					

## Overview of Controllers

Art. No.	0.0.668.62	0.0.668.63	0.0.668.65
Product name	Controller C 1-02	Controller C 1-05	Controller C 3-05
Output power (rated) [KVA]	0.5	1.0	3
Max. output power (for 5 s) [KVA]	1	2	6
Rated output current [A]	2.5	5	5
Max. output current [A]	10	10	6
Control voltage	24 VDC (+20 %) [0.55 A]	24 VDC (+20 %) [0.65 A]	24 VDC (+20 %) [1 A]
Intermediate circuit voltage	360 ... 380 V / 310 ... 320 V (with/without Power Factor Control)		560 ... 570 V
External brake resistance, max. continuous braking power [Ohm]	≥ 50		≥ 40
Supply voltage	1 x 100 ... 230 VAC (+- 10%), 50 ... 60 Hz		3 x 230 ... 480 VAC (+- 10%), 50 ... 60 Hz
Alternative DC infeed	60 .. 380 VDC		60 .. 700 VDC
Clock rate	Variable cycle frequencies up to 20 KHz, operational data at 1 x 230 VAC (+-10 %), 50 Hz		Variable cycle frequencies up to 16 KHz, operational data at 3 x 400 VAC (+-10 %), 50 Hz
Holding brake	24 VDC, max. 1A		24 VDC, max. 2A
Storage temperature	- 25°C to +70°C		
Operating temperature	0°C to +40°C and +40°C to +50°C with power reduction of 2.5% / K		
Reliable installation height	Max. installation height 2000 m over NN, with power reduction of 1% per 100 m starting from 1000 m		
Humidity	Less than 90% relative humidity (without condensing)		
Protection class	IP 20		
Protection class	1		
Pollution degree to IEC 61010	2		
Conformity	CE, UL		
Low Voltage Directive	2006/95/EC, verified via application of harmonised standard EN 61800-3		
EMC Directive	2004/108/EC, verified via application of harmonised standard EN 61800-3		
Inputs	10 x digital in (24 VDC) // 3 x analogue in (+-10 VDC, 2 x 10 Bit, 1 x 16 Bit)		
Outputs	4 x digital out (24 VDC) // 1 x digital out (24 VDC) for holding brake // 2 x analogue out (+- 10 VDC, 9 Bit)		
Interfaces (standard)	USB 2.0, Ethernet, RS232/RS485, Can-Bus (CANopen DSP 402)		
Interfaces (optional)	EtherCAT, PROFIBUS-DP, PROFINET		
Encoder evaluation	Universal encoder interface for motors with a resolver, HIPERFACE interface for motors with an absolute encoder		

# Alphabetical Register

## A

Accessories for Synchronising Shaft Profiles 100

## C

Carriage Plate 6 60 190x60 141

Carriage plates KLE 141

Conduit and Lid Profiles 105

Controller BL 1-04/C 127

Controllers C 1 129

Controller C 3-05 130

## D

Data Cables 133

Drive Set 5 40 D30/D12 85

Drive Set 8 40 D40/D15 86

Drive Set 8 80 D55/D34 86

Drive Set 8 80 D80/D34 86

Drive Set 8 D40/D15 AP/WP 75

Drive Set GSF 8 40 80

Drive Set GSF 8 40 AP/WP 69

Drive Set KGT 6 60 - universal 87

Drive Set KGT D40/D15 88

Drive Set KRF 8 ZR 83

Drive Set ZS 90

Drive Sets KGT 6 60 SE 76

Drive Sets KGT D40/D15 SE 77

Drive Sets KLE 81

Drive Sets KLE AP/WP 70

Drive Sets KRF AP/WP 72

Drive Sets LRE 84

Drive Sets ZS AP/WP 78

Drive Sets ZU AP/WP 73

## E

EtherCAT Interface 132

## G

Gearbox AP 60 111

Gearbox AP 80 112

Gearbox WP 60 115

Gearbox WP 80 116

Gearboxes AP 40 110

Gearboxes WP 40 114

## I

I/O Cable (C Series) 150

I/O Interface Module (C Series) 150

item MotionKit Linear Unit KGT 6 60 P20-1400 65

item MotionKit Linear Unit KGT 6 60 P20-1400 - BL 64

item MotionKit Linear Unit KGT 6 60 P20-2600 65

item MotionKit Linear Unit KGT 6 60 P20-2600 - BL 64

item MotionKit Linear Unit KGT 6 60 P20-600 65

item MotionKit Linear Unit KGT 6 60 P20-600 - BL 64

## L

Linear Guide 6 60 PS 140

Linear Guide 6 60 PS Transverse Carriage 140

Linear Unit GSF 8 40 R10 20

Linear Unit KGT 6 60 P20 46

Linear Unit KLE 6 60x60 LR 23

Linear Unit KLE 8 80x80 LR 24

Linear Unit LRE 5 D6 60x20 ZU 40 R10 28

Linear Unit LRE 8 D10 30

Linear Unit LRE 8 D10 80x40 ZS K light 58

Linear Unit LRE 8 D10 80x40 ZU 40 R25 31

Linear Unit LRE 8 D10 80x80 KGT 20x20 50

Linear Unit LRE 8 D10 80x80 KGT 20x5 49

Linear Unit LRE 8 D10 80x80 ZU 40 R25 32

Linear Unit LRE 8 D14 120x80 ZU 40 R25 38

Linear Unit LRE 8 D14 120x80 ZU 80 R25 39

Linear Unit LRE 8 D14 80x40 KU 80 55

Linear Unit LRE 8 D14 80x40 ZS 60

Linear Unit LRE 8 D14 80x40 ZU 40 R25 34

Linear Unit LRE 8 D14 80x40 ZU 80 R25 35

Linear Unit LRE 8 D14 80x80 KGT 20x20 53

Linear Unit LRE 8 D14 80x80 KGT 20x5 52

Linear Unit LRE 8 D14 80x80 ZU 40 R25 36

Linear Unit LRE 8 D14 80x80 ZU 80 R25 37

Linear Unit LRE 8 D25 120x80 ZU 80 R25 41

Linear Unit LRE 8 D25 120x80 ZU 80 R50 42

Linear Unit LRE 8 D25 200x80 ZU 80 R25 43

Linear Unit LRE 8 D25 200x80 ZU 80 R50 44

Linear Units KLE 22

Linear Units KRF 25

Linear Units LRE 8 D10 80x80 KGT 48

Linear Units LRE 8 D14 33

Linear Units LRE 8 D14 80x80 KGT 51

Linear Units LRE 8 D25 40



# Alphabetical Register

## M

Motors SE 40	119, 120
Motors SE 60	122
Motors SE 80	124

## O

Oil Can for Linear Guides	152
---------------------------	-----

## P

Pin Spanners	151
Power Cables	133
PROFIBUS Interface	132
PROFINET Interface	132
Profile Fastening Set 6/8 80x60	143
Proximity Switch Sets	148
Proximity Switches	146
Proximity-Switch Cam	146
Proximity-Switch Connecting Cable	146

## S

Safety Module STO	131
Shield terminal block D14	137
Slide Stop LRE 8	144
Synchroniser Shaft Cover Sets	102
Synchronising Set D30/D12	97
Synchronising Set D40/D15	97
Synchronising Set D55/D34	97
Synchronising Set D80/D34	97
Synchronising Set GSF 8 40 R10	93
Synchronising Set KRF 8 80 ZR	95
Synchronising Sets KLE	94
Synchronising Sets LRE	96
Synchronising Shaft Profile VK32	99

## T

Track Oil for Linear Guides	152
Transverse Carriage Plate 6 60 190x119	141
Transverse Carriage Plate KLE 6 60x60	141
Transverse Carriage Plate KLE 8 80x80	141
Tubes for Synchronising Sets	98

# The item product catalogues



**Work Bench System**  
Manual production is more productive with the ergonomic work benches of the item Work Bench System.

[item24.de/en/epaper-wbs](http://item24.de/en/epaper-wbs)



**Automation System**  
Automation perfectly coordinated: Linear Units, Motors and Controllers combine to form ready-to-install turnkey systems.

[item24.de/en/epaper-au](http://item24.de/en/epaper-au)



**Line XMS**  
Complete machine modules help you build machine enclosures in record time.

[item24.de/en/epaper-xm](http://item24.de/en/epaper-xm)



**Lean Production Building Kit System**  
The Lean Production Building Kit System: The simple way to build what modern lean production needs.

[item24.de/en/epaper-lp](http://item24.de/en/epaper-lp)

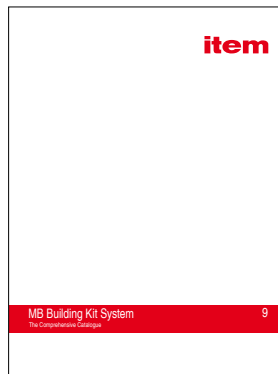

**MB Building Kit System**  
The MB Building Kit System is the solution for all design and construction tasks involving mechanical and factory equipment engineering.

[item24.de/en/epaper-mb](http://item24.de/en/epaper-mb)



**Stairway/Platform System**  
The Stairway/Platform System produces bridges and maintenance platforms in one uniform look.

[item24.de/en/epaper-tp](http://item24.de/en/epaper-tp)



All the information you need at your fingertips

item product catalogues are available online as clearly laid out and convenient e-papers. Take your pick and get browsing!

#### **Patents**

Many of the components and products contained in this catalogue are subject to industrial property rights. Any copying of protected products is a violation of these rights and, as such, shall be liable to compensation. Data and illustrations in this catalogue do not discharge the users from the obligation to carry out their own checks to determine whether the industrial property rights of third parties are infringed.

#### **Product liability**

item shall be liable, within the framework of the applicable legal provisions, for the promised characteristics of the products shown in this catalogue. Any claims for liability above and beyond such – in particular relating to products created by third parties using products included in this catalogue – are expressly excluded.

#### **Conditions of use**

The products in the item MB Building Kit System are suitable for use in dry conditions and over the temperature range -20°C to +70°C. item must be consulted where products are to be used for applications outside these limits.

#### **Conformity with Directive 2011/65/EU ("RoHS")**

item has made a voluntary undertaking to refrain from using hazardous substances as defined in Directive 2011/65/EU in the products it sells, irrespective of their subsequent purpose which, in the majority of cases, does not fall under this Directive. As a result, apart from a few well-founded exceptions, the products listed in this catalogue comply with Directive 2011/65/EU. The products to which these exceptions relate are set out in an up-to-date list that is available to customers on request.

#### **Concept, design and realisation**

item Industrietechnik GmbH

#### **Photographs**

item Industrietechnik GmbH

Technical modifications and errors reserved.

All rights reserved. Use of texts and illustrations or reprints of any kind only permitted with prior written consent from item. This applies in particular to reproduction, translation or use in electronic systems.

**item** and the item claim are a registered trademark of item Industrietechnik GmbH.

© item Industrietechnik GmbH 2021

Your distribution and service partner

**item**

item Industrietechnik GmbH  
Friedenstrasse 107-109  
42699 Solingen  
Germany

Telephone +49 212 6580 0  
Fax +49 212 6580 310

[info@item24.com](mailto:info@item24.com)  
[item24.com](http://item24.com)

Your ideas are worth it.®