

## LOW PROFILE LINEAR MODULES





Aluflex Group operates throughout the Nordic region, delivering automation solutions to the Scandinavian market.

We collaborate with the industry's leading suppliers of automation products. Our extensive product range includes item aluminum profile systems, belt conveyors, roller conveyors, modular and chain conveyors, pallet conveyors, and workstation systems. Additionally, we offer linear motion products such as linear guides, ball screws, linear modules, telescopic movements, and rack-and-pinion solutions.

From our workshop and large warehouse in Helsingborg, we provide customized engineering solutions and optimized logistics. We have the capability to cut, process, and assemble quickly according to your specific requirements. To facilitate design work, CAD and PDF-files are available on our website.

Aluflex turns ideas into complete solutions!

# Index

page

## Products

Linear Modules - Inner Structure .....	4
GLTH3 - Ball screw .....	6
GLTH5 - Ball screw .....	9
GLTH8 - Ball screw .....	12
GLTH12 - Ball screw .....	15
GLTB5 - Belt driven .....	18
GLTB8 - Belt driven .....	20
GLTH5D - Ball screw .....	22
GLTH8D - Ball screw .....	25
GLTH12D - Ball screw .....	28

## Product facts

Article numbers for the linear modules .....	31
Sample Solutions .....	32

## Accessories

Gantry Profile X - Y .....	33
Cross Plates Y - Z .....	34
Lubrication advice .....	35
Lifetime calculation .....	35

## Height reduction, convenient for assembly.

Our high-quality and compact linear modules are designed for optimal performance and efficiency. With embedded bearings within the profile, they maximize space utilization while maintaining a sleek, low-profile design. They offer higher moment load capacity without compromising functionality and use less material, reducing weight and lowering the carbon footprint.

We provide complete motor packages and a fully integrated X-Y-Z plate system. All modules are stocked and assembled in Helsingborg, Sweden, with spare parts readily available for fast and reliable support.

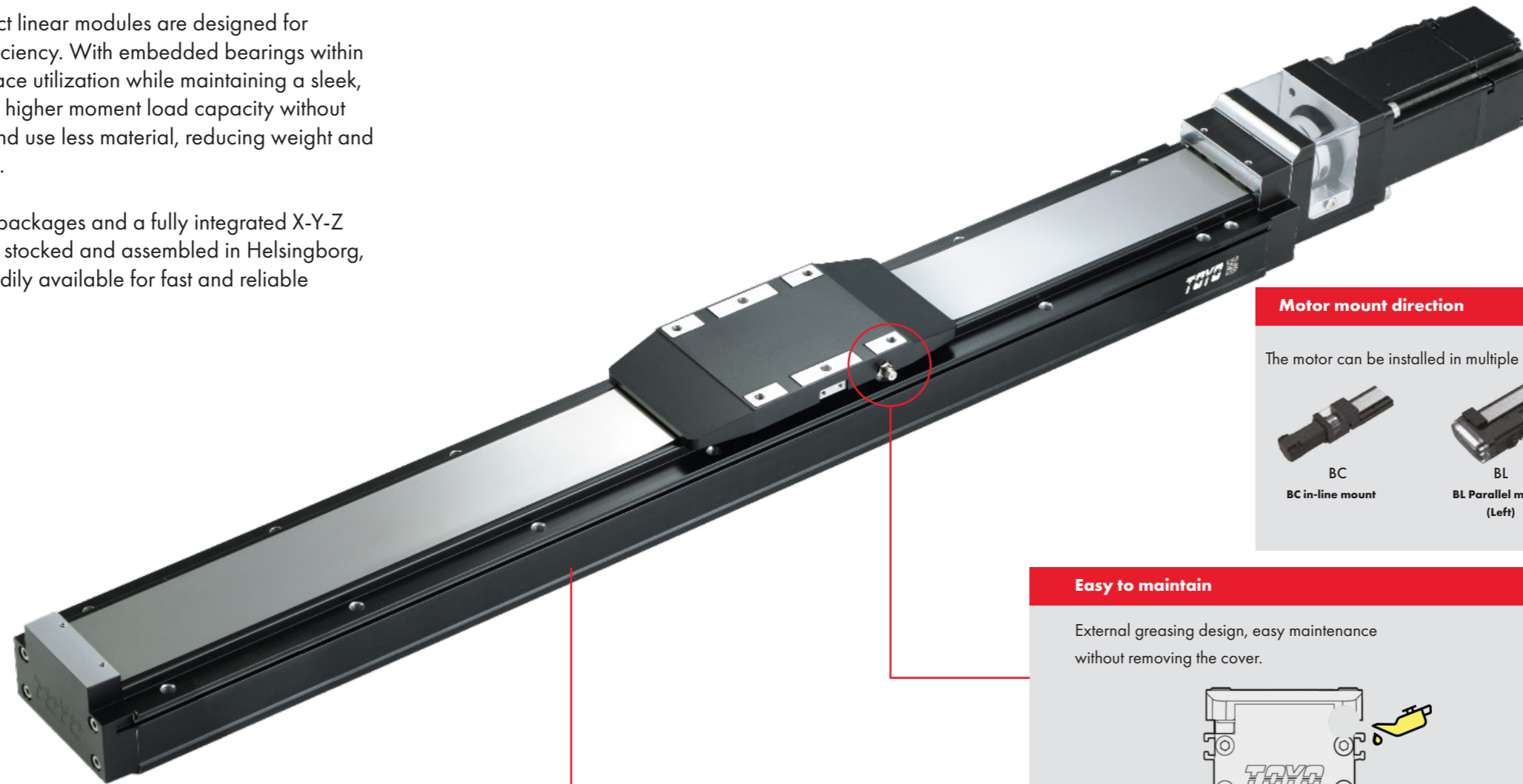

## Inner structure

### Built-in linear motion guide ball screw actuator

#### Motor mount direction

The motor can be installed in multiple directions, providing flexibility in machine design.

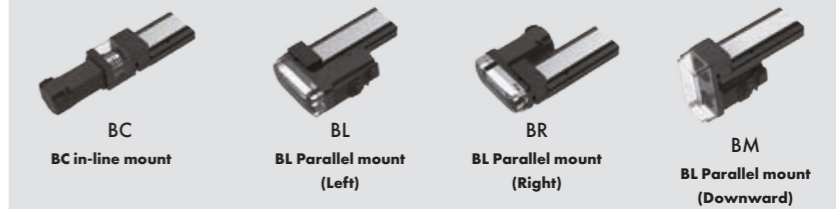

#### Easy to maintain

External greasing design, easy maintenance without removing the cover.

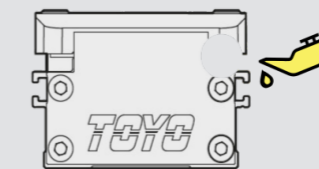

#### Reduce dust

Special steel strip cover sealing design can prevent dirt and foreign objects from penetrating inside. Can be used in clean room environment.

#### Flatness and Straightness

Built in linear rail design, straightness and flatness reach up to  $\pm 0.02\text{mm}$ .

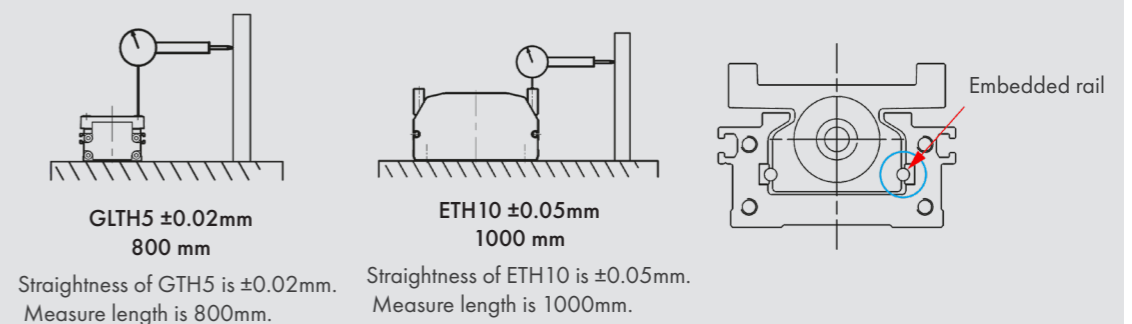

#### Easy assembly

No need to disassemble the steel strip; it can be fixed from top to bottom or from bottom to top

Mounting datum plane designed on the side of the body

Built in Pin holes (options)

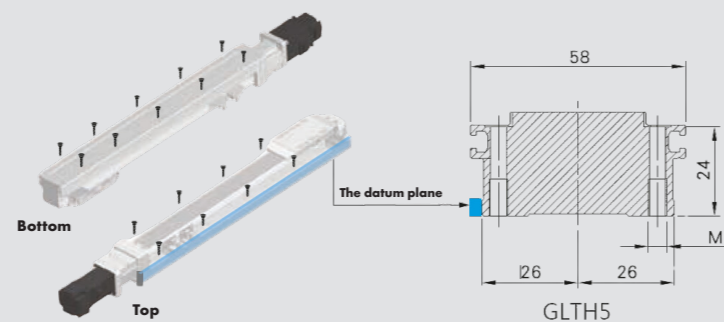

# GLTH3 - Ball screw



Maximum Speed  
480 mm/s

Maximum Stroke  
500 mm

Max Payload  
13 kg

Specification			
Repeatability	mm	±0.005	
Lead (Perimeter on Drive Wheel)	mm	2	8
Maximum Rotating Speed	rpm	3600	3600
Maximum linear speed	mm/s	120	480
Maximum Payload	Horizontal	kg	13
	Vertical	kg	5
Rated Thrust	N	352	88
Stroke (Increments)	mm	50-500mm/50 (50 increments)	
Maximum acceleration	G	0.3	0.3
Ball screw	Basic dynamic load rating Ca	N	1811
	Basic static load rating Coa	N	2774
Linear Guide	Dynamic horizontal (100km)	N	3144
	Static Horizontal	N	6707
Fixed bearing	Basic dynamic load rating Cr	N	2819
	Static load rating Cor	N	1342
Ball screw Ø	mm	C7Ø6	
Coupling	mm	4X5	

During long strokes, ballscrew deflection can occur, so the speed must be reduced (refer to the linear velocity in the data sheet below the dimension graph).

## Allowable Overhang

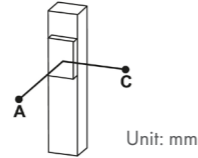
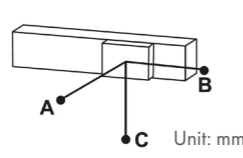
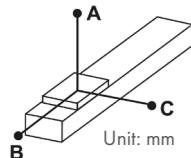

Horizontal Installation				Wall Installation				Vertical Installation				
		A	B	A	B	C	A	B	C	A	B	C
2 Lead	10kg	364	13	15	10kg	15	13	364	2 Lead	3kg	55	55
	12kg	260	10	11	12kg	11	10	260	2 Lead	5kg	33	33
	13kg	266	9	10	13kg	10	9	266	2 Lead	-	-	-
8 Lead	6kg	117	17	18	6kg	18	17	117	8 Lead	1kg	120	120
	8kg	84	12	12	8kg	12	12	84	8 Lead	2kg	60	60
	10kg	64	9	9	10kg	9	9	64	8 Lead	-	-	-

## Static Loading Moment

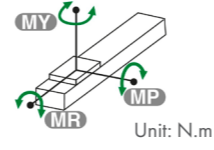

MY	39
MP	39
MR	41

The data presented in the moment table represents the center of gravity of the load. The overhang length is allowed in a single direction only. The operational life is 10,000 km when the product is used under the specified conditions. The provided data does not apply to ceiling-mounted inverse use. Please contact us for details if you intend to use the product in a ceiling-mounted inverse configuration. Life and torque values are calculated based on motor acceleration and deceleration times of 0.2 seconds.

## BC GLTH3 - Motor Exposed

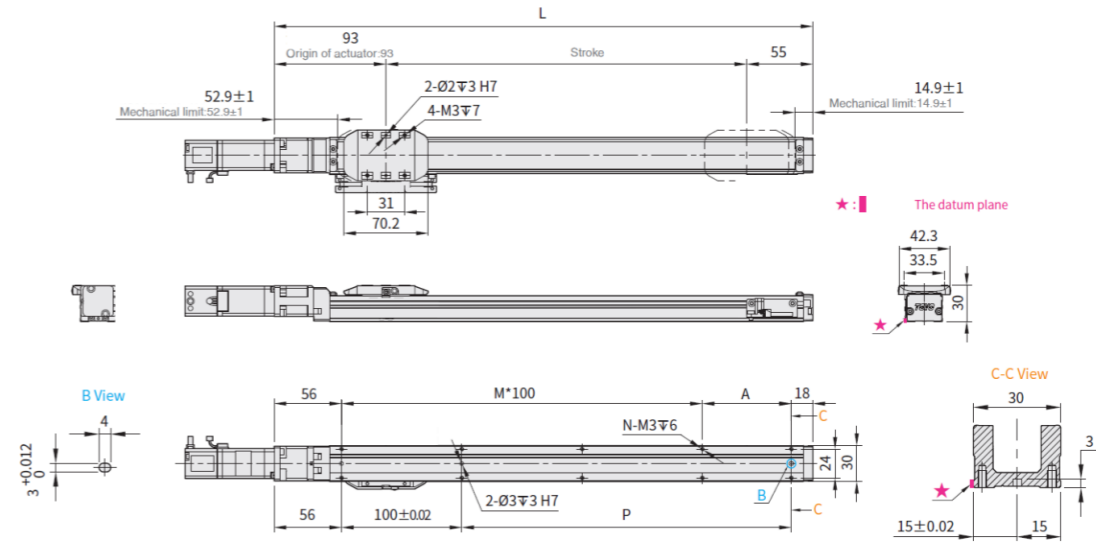

## BM GLTH3 - Motor Bottom

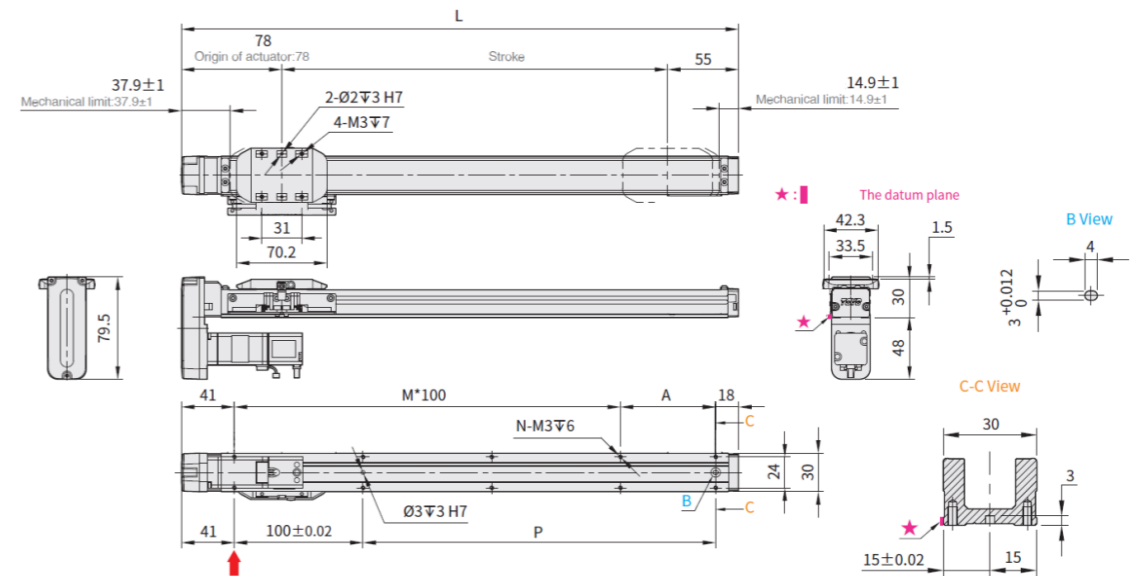

Please note that this thread hole will be covered by motor.

Stroke	50	100	150	200	250	300	350	400	450	500
Limit Stroke (±1)	60	110	160	210	260	310	360	410	460	510
L	BC	198	248	298	348	398	448	498	548	598
	BM	183	233	283	333	383	433	483	533	583
A	24	74	124	174	224	274	324	374	424	474
M	1	1	2	2	3	3	4	4	5	5
N	6	6	8	8	10	10	12	12	14	14
P	24	74	124	174	224	274	324	374	424	474
KG	MC	0.29	0.34	0.4	0.44	0.49	0.55	0.61	0.67	0.73
	BM	0.38	0.48	0.57	0.66	0.76	0.85	0.94	1.03	1.12
Linear Speed mm/s	Lead 2	120	107	90	80	70	60	50	40	
	Lead 8	480	427	360	320	280	240	200	160	

When motor with brake assembled on lower side, or the total length over than spec limit, it may not use standard pinhole. Please contact our sales department if you need more information & requirement.



### GLTH5- Motor Exposed

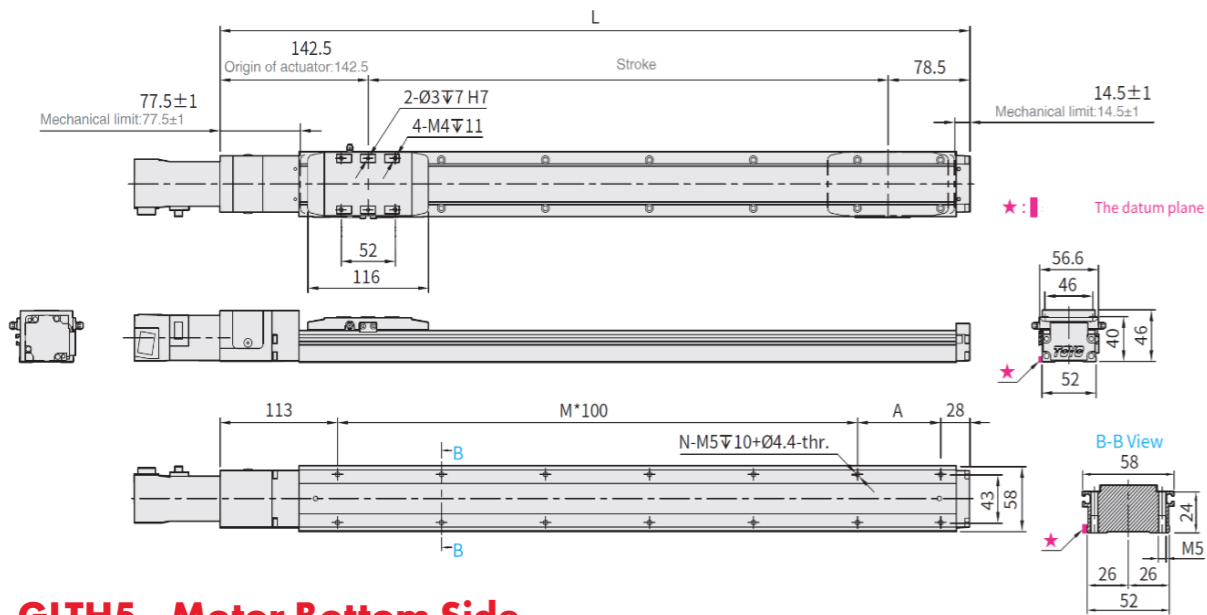

### GLTH5 - Motor Bottom Side

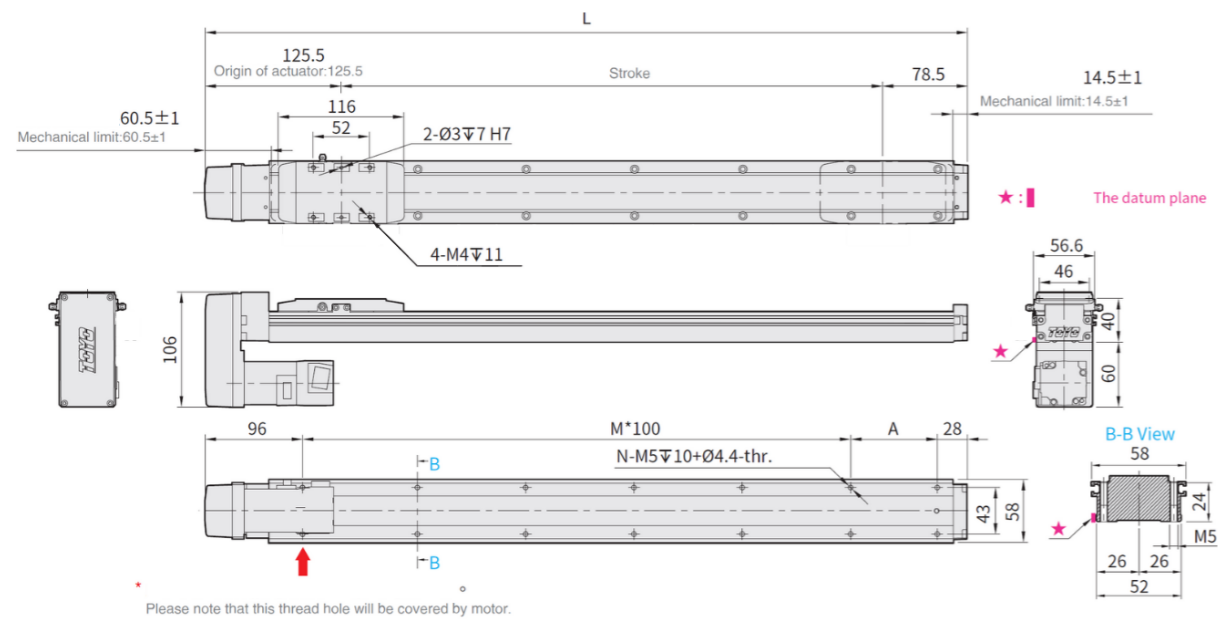

Stroke	50 <sup>-1</sup>	100	150	200	250	300	350	400	450	500	550	600	650	700	750	800	850	900	950	1000	
Limit Stroke (±1)	63	113	163	213	263	313	363	413	463	513	563	613	663	713	763	813	863	913	963	1013	
L	BC	271	321	371	421	471	521	571	621	671	721	771	821	871	921	971	1021	1071	1121	1171	1221
	BM	254	304	354	404	454	504	554	604	654	704	754	804	854	904	954	1004	1054	1104	1154	1204
A	30	80	30	80	30	80	30	80	30	80	30	80	30	80	30	80	30	80	30	80	30
M	1	1	2	2	3	3	4	4	5	5	6	6	7	7	8	8	9	9	10	10	10
N	6	6	8	8	10	10	12	12	14	14	16	16	18	18	20	20	22	22	24	24	24
KG	MC	1.06	1.19	1.32	1.44	1.57	1.69	1.82	1.95	2.07	2.2	2.33	2.45	2.58	2.71	2.83	2.96	3.08	3.21	3.34	3.46
	BM	1.16	1.29	1.42	1.54	1.67	1.79	1.92	2.05	2.17	2.3	2.43	2.55	2.68	2.81	2.93	3.06	3.18	3.31	3.44	3.56
Linear Speed mm/s	Lead 2										110	90	80	70	63	53	50	43	40	36	
	Lead 6										330	270	240	210	190	160	150	130	120	110	
	Lead 12										660	540	480	420	380	320	300	260	240	220	
	Lead 20										1100	900	800	700	630	533	500	430	400	367	

When the stroke is 50 mm, fixing the body from top to bottom will cause the slider to block the fixing holes, allowing only 4 screws to be used. Therefore, it is recommended to fix the actuator body from bottom to top.

### GLTH5 - Motor Left Side

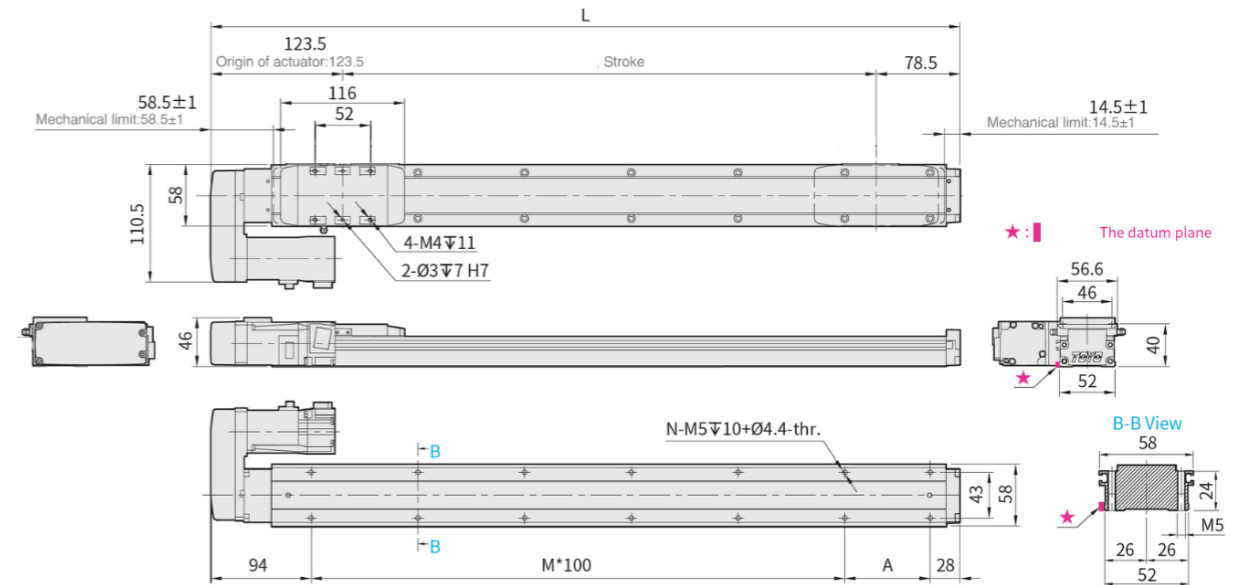

### GLTH5 - Motor Right Side

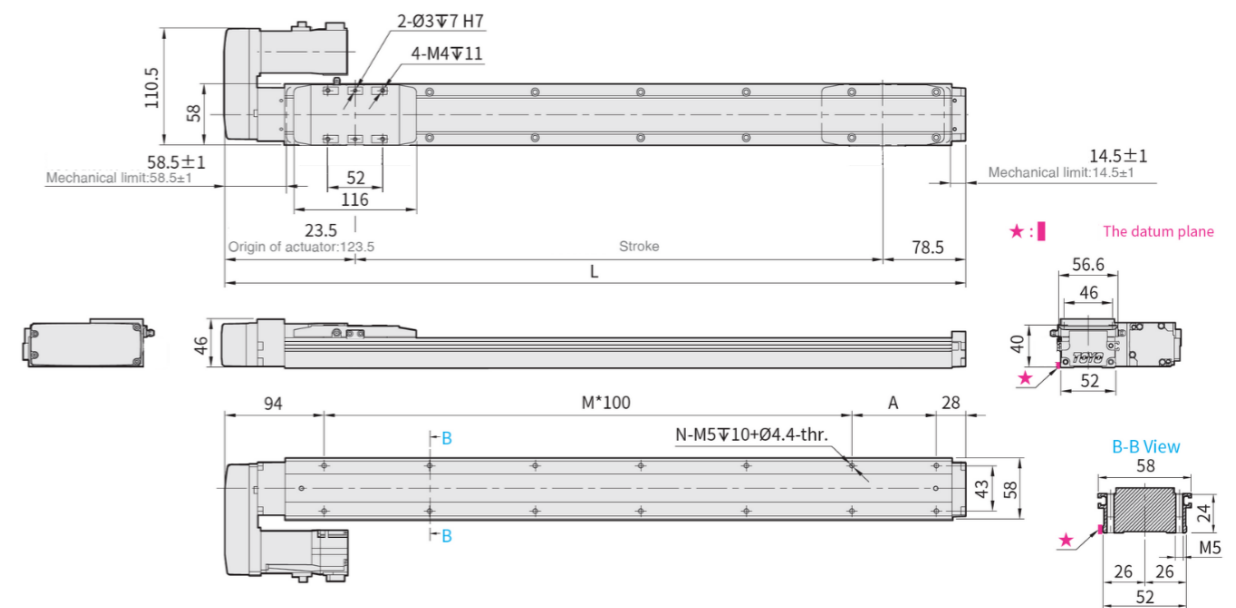

Stroke	50 <sup>-1</sup>	100	150	200	250	300	350	400	450	500	550	600	650	700	750	800	850	900	950	1000
Limit Stroke (±1)	63	113	163	213	263	313	363	413	463	513	563	613	663	713	763	813	863	913	963	1013
L	252	302	352	402	452	502	552	602	652	702	752	802	852	902	952	1002	1052	1102	1152	1202
A	30	80	30	80	30	80	30	80	30	80	30	80	30	80	30	80	30	80	30	80
M	1	1	2	2	3	3	4	4	5	5	6	6	7	7	8	8	9	9	10	10
NP	6	6	8	8	10	10	12	12	14	14	16	16	18	18	20	20	22	22	24	24
KG	1.16	1.29	1.42	1.54	1.67	1.79	1.92	2.05	2.17	2.3	2.43	2.55	2.68	2.81	2.93	3.06	3.18	3.31	3.44	3.56
Linear Speed mm/s	Lead 2										110	90	80	70	63	53	50	43	40	36
	Lead 6										330	270	240	210	190	160	150	130	120	110
	Lead 12										660	540	480	420	380	320	300	260	240	220
	Lead 20										1100	900	800	700	630	533	500	430	400	367

When the stroke is 50 mm, fixing the body from top to bottom will cause the slider to block the fixing holes, allowing only 4 screws to be used. Therefore, it is recommended to fix the actuator body from bottom to top.

# GLTH8 - Ball screw



Maximum Speed  
1440 mm/s

Maximum Stroke  
1250 mm

Max Payload  
80 kg

## Specification

Repeatability	mm	±0.005			
Lead (Perimeter on Drive Wheel)	mm	6	12	24	
Maximum Rotating Speed	rpm	3600	3600	3600	
Maximum linear speed	mm/s	360	720	1440	
Maximum Payload	Horizontal	kg	80	60	40
	Vertical	kg	15	8	5
Rated Thrust	N	569	284	142	
Stroke (Increments)	mm	50-1250mm/50 (50 increments)			
Maximum acceleration	G	0.37	0.73	1.47	
Ball screw	Basic dynamic load rating Ca	N	7733	5855	3007
	Basic static load rating Coa	N	14200	10401	5414
Linear Guide	Dynamic horizontal (100km)	N	4007		
	Static Horizontal	N	34189		
Fixed bearing	Basic dynamic load rating Cr	N	8447		
	Static load rating Cor	N	5060		
Ball screw Ø	mm	C7Ø14			
Coupling	mm	10x14/11			

During long strokes, ballscrew deflection can occur, so the speed must be reduced (refer to the linear velocity in the data sheet below the dimension graph). Since the motor performance of each brand is different, a regenerative resistor needs to be appropriately matched to achieve this load condition. Motor (200W) Shaft Diameter: Panasonic: 11mm; Other: 14mm.

## Allowable Overhang

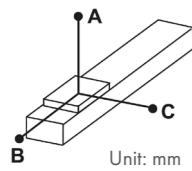

Unit: mm

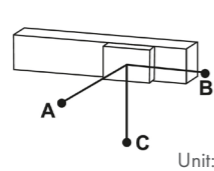

Unit: mm

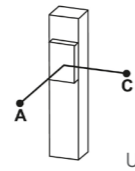

Unit: mm

Horizontal Installation				Wall Installation				Vertical Installation				
	A	B	C	A	B	C	A	C	A	C	A	C
6 Lead	35kg	1600	139	220	139	1600	10kg	535	535	15kg	360	360
	45kg	1210	102	160	102	1210	80kg	-	-	-	-	-
	80kg	620	46	74	46	620	3.5kg	1380	1380	-	-	-
12 Lead	10kg	2040	470	645	470	2040	8kg	605	605	-	-	-
	30kg	638	141	193	141	638	-	-	-	-	-	-
	60kg	283	58	80	58	283	-	-	-	-	-	-
24 Lead	20kg	253	145	133	145	253	2kg	1380	1380	-	-	-
	40kg	109	60	55	60	109	5kg	556	556	-	-	-
	-	-	-	-	-	-	-	-	-	-	-	-

## Static Loading Moment

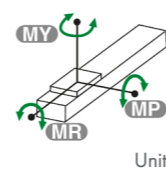

Unit: N.m

MY	271
MP	271
MR	449

The data presented in the moment table represents the center of gravity of the load. The overhang length is allowed in a single direction only. The operational life is 10,000 km when the product is used under the specified conditions. The provided data does not apply to ceiling-mounted inverse use. Please contact us for details if you intend to use the product in a ceiling-mounted inverse configuration. Life and torque values are calculated based on motor acceleration and deceleration times of 0.2 seconds.

## BC GLTH8 - Motor Exposed

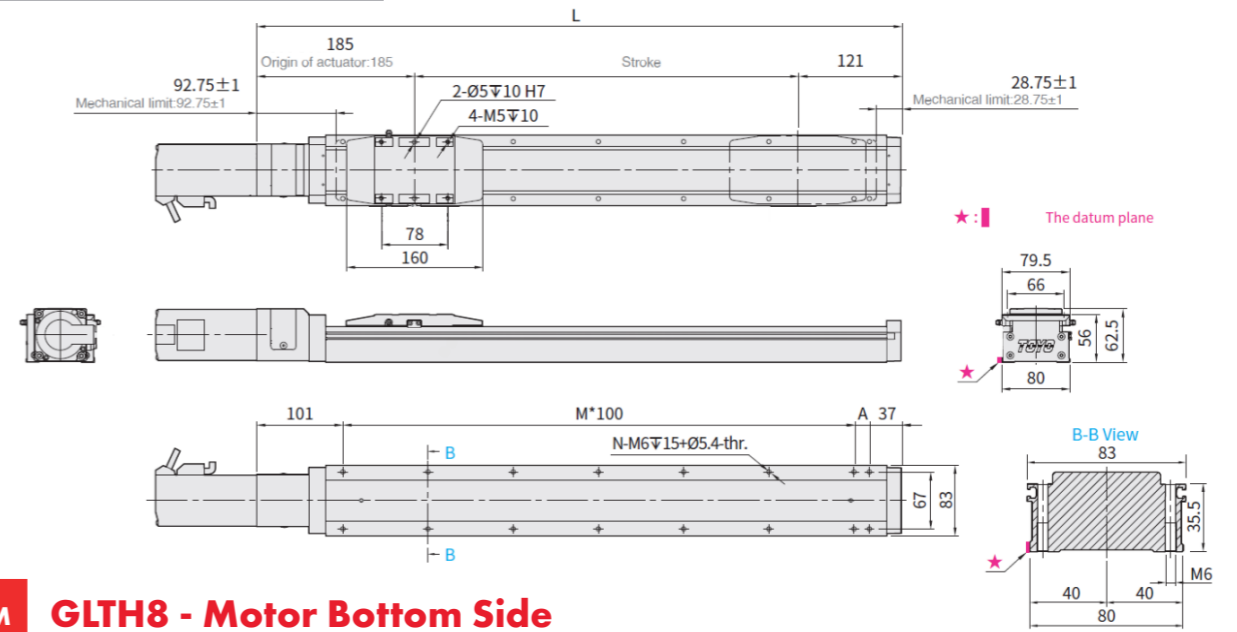

## BM GLTH8 - Motor Bottom Side

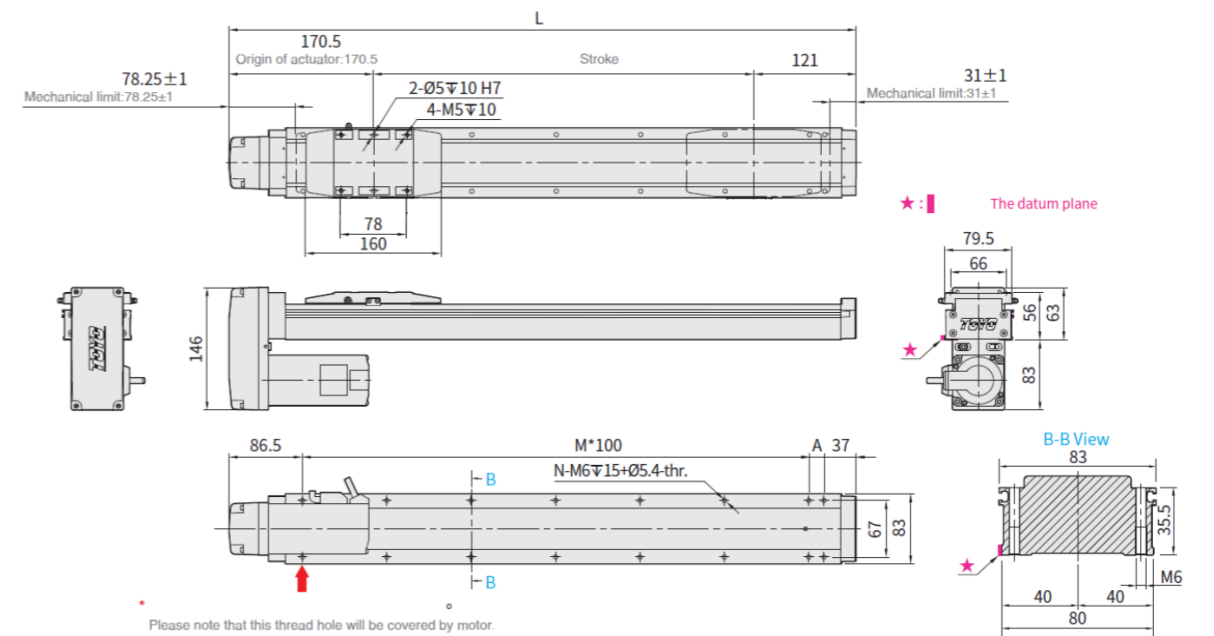

Please note that this thread hole will be covered by motor.

Stroke	50	100	150	200	250	300	350	400	450	500	550	600	650	700	750	800	850	900	950	1000	1050	1100	1150	1200	1250	
Limit Stroke (±1)	74.5	124.5	174.5	224.5	274.5	324.5	374.5	424.5	474.5	524.5	574.5	624.5	674.5	724.5	774.5	824.5	874.5	924.5	974.5	1024.5	1074.5	1124.5	1174.5	1224.5	1274.5	
L	BC	356	406	456	506	556	606	656	706	756	806	856	906	956	1006	1056	1106	1156	1206	1256	1306	1356	1406	1456	1506	1556
	BM	341.5	391.5	441.5	491.5	541.5	591.5	641.5	691.5	741.5	791.5	841.5	891.5	941.5	991.5	1041.5	1091.5	1141.5	1191.5	1241.5	1291.5	1341.5	1391.5	1441.5	1491.5	1541.5
A	18	68	18	68	18	68	18	68	18	68	18	68	18	68	18	68	18	68	18	68	18	68	18	68	18	68
M	2	2	3	3	4	4	5	5	6	6	7	7	8	8	9	9	10	10	11	11	12	12	13	13	14	
N	8	8	10	10	12	12	14	14	16	16	18	18	20	20	22	22	24	24	26	26	28	28	30	30	32	
KG	BC	2.31	2.61	2.9	3.2	3.49	3.79	4.09	4.38	4.68	4.97	5.27	5.57	5.87	6.16	6.46	6.75	7.05	7.35	7.64	7.94	8.24	8.53	8.83	9.13	9.42
	BM	2.68	2.98	3.27	3.57	3.87	4.16	4.46	4.75	5.05	5.35	5.64	5.94	6.24	6.53	6.83	7.13	7.42	7.72	8.01	8.31	8.61	8.9	9.2	9.5	9.79
	Lead 6	360										350	310	270	240	210	190	170	160	140	130	120	110	100	90	
Linear Speed mm/s	Lead 12	720										700	620	540	480	420	380	340	320	280	260	240	220	200	180	
	Lead 24	1440										1400	1240	1080	960	840	760	680	640	560	520	480	440	400	360	

When the stroke is 50 mm, fixing the body from top to bottom will cause the slider to block the fixing holes, allowing only 4 screws to be used. Therefore, it is recommended to fix the actuator body from bottom to top.

**BL GLTH8 - Motor Left Side**

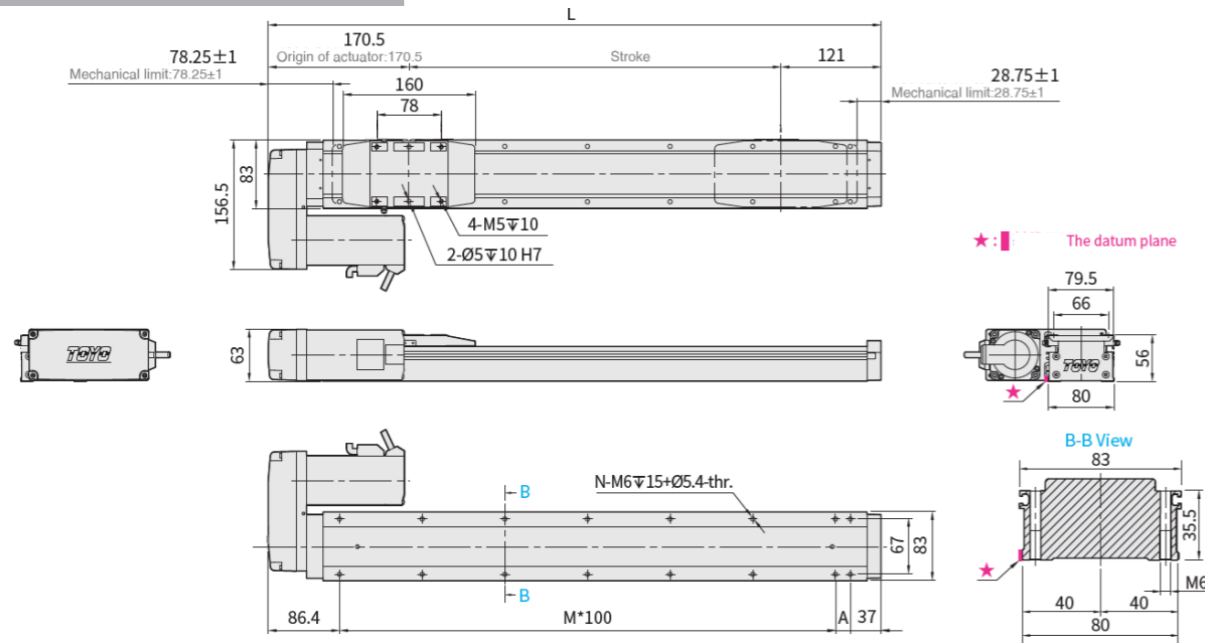

**BR GLTH8 - Motor Right Side**

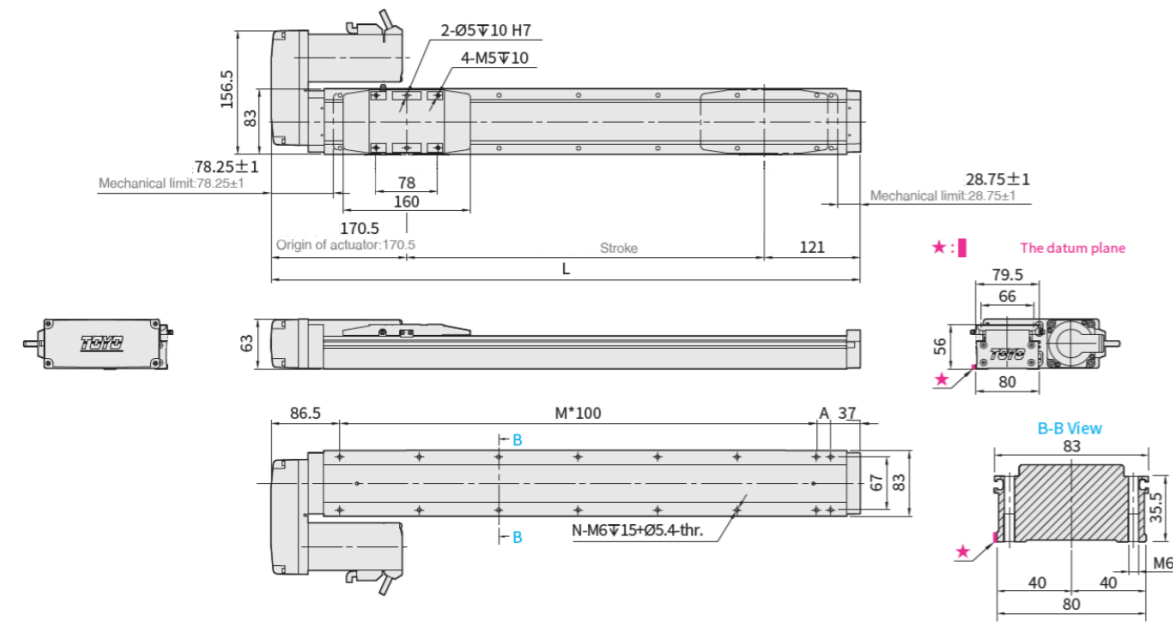

Stroke	50 <sup>(1)</sup>	100	150	200	250	300	350	400	450	500	550	600	650	700	750	800	850	900	950	1000	1050	1100	1150	1200	1250		
Limit Stroke (±1)	74.5	124.5	174.5	224.5	274.5	324.5	374.5	424.5	474.5	524.5	574.5	624.5	674.5	724.5	774.5	824.5	874.5	924.5	974.5	1024.5	1074.5	1124.5	1174.5	1224.5	1274.5		
L	341.5	391.5	441.5	491.5	541.5	591.5	641.5	691.5	741.5	791.5	841.5	891.5	941.5	991.5	1041.5	1091.5	1141.5	1191.5	1241.5	1291.5	1341.5	1391.5	1441.5	1491.5	1541.5		
A	18	68	18	68	18	68	18	68	18	68	18	68	18	68	18	68	18	68	18	68	18	68	18	68	18		
M	2	2	3	3	4	4	5	5	6	6	7	7	8	8	9	9	10	10	11	11	12	12	13	13	14		
N	8	8	10	10	12	12	14	14	16	16	18	18	20	20	22	22	24	24	26	26	28	28	30	30	32		
KG	2.68	2.98	3.27	3.57	3.87	4.16	4.46	4.75	5.05	5.64	5.64	5.94	6.24	6.53	6.83	7.13	7.42	7.72	8.01	8.31	8.61	8.9	9.2	9.5	9.79		
Linear Speed mm/s																											
	Lead 6	360																									
	Lead 12	720																									
Lead 24	1440																										

When the stroke is 50 mm, fixing the body from top to bottom will cause the slider to block the fixing holes, allowing only 4 screws to be used. Therefore, it is recommended to fix the actuator body from bottom to top.

**GLTH12 - Ball screw**



Maximum Speed  
1440 mm/s

Maximum Stroke  
1250 mm

Max Payload  
110 kg

Specification				
Repeatability	mm	±0.005		
Lead (Perimeter on Drive Wheel)	mm	6	12	24
Maximum Rotating Speed	rpm	3600	3600	3600
Maximum linear speed	mm/s	360	720	1440
Maximum Payload	Horizontal	kg	110	88
	Vertical	kg	29	15
Rated Thrust	N	1156	578	289
Stroke (Increments)	mm	50-1250mm/50 (50 increments)		
Maximum acceleration	G	0.37	0.73	1.47
Ball screw	Basic dynamic load rating Ca	N	7733	5855
	Basic static load rating Coa	N	14200	10401
Linear Guide	Dynamic horizontal (100km)	N	51128	
	Static Horizontal	N	84518	
Fixed bearing	Basic dynamic load rating Cr	N	2600	
	Static load rating Cor	N	4750	
Ball screw Ø	mm	C7Ø14		
Coupling	mm	10x14		

During long strokes, ballscrew deflection can occur, so the speed must be reduced (refer to the linear velocity in the data sheet below the dimension graph). Since the motor performance of each brand is different, a regenerative resistor needs to be appropriately matched to achieve this load condition. Motor (200W) Shaft Diameter: Panasonic: 11mm; Other: 14mm.

**Allowable Overhang**

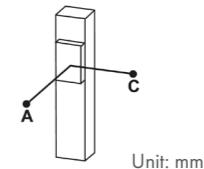
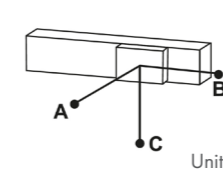
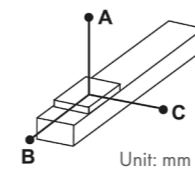

Horizontal Installation	A	B	C
6 Lead	60kg	1900	268
	80kg	1428	184
	110kg	963	114
12 Lead	60kg	1538	483
	70kg	1300	406
	88kg	1010	311
24 Lead	20kg	1285	693
	30kg	835	450
	40kg	613	328

Wall Installation	A	B	C
6 Lead	60kg	268	1990
	80kg	184	1428
	110kg	114	963
12 Lead	60kg	483	1538
	70kg	406	1300
	88kg	311	1010
24 Lead	20kg	693	1285
	30kg	450	835
	40kg	328	613

Vertical Installation	A	C
6 Lead	20kg	1250
	29kg	870
	-	-
12 Lead	10kg	2250
	15kg	1500
	-	-
24 Lead	7kg	1840
	9kg	1430
	-	-

**Static Loading Moment**

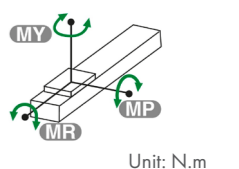

MY	606
MP	606
MR	1168

The data presented in the moment table represents the center of gravity of the load. The overhang length is allowed in a single direction only. The operational life is 10,000 km when the product is used under the specified conditions. The provided data does not apply to ceiling-mounted inverse use. Please contact us for details if you intend to use the product in a ceiling-mounted inverse configuration. Life and torque values are calculated based on motor acceleration and deceleration times of 0.2 seconds.

**BC GLTH12 - Motor Exposed**

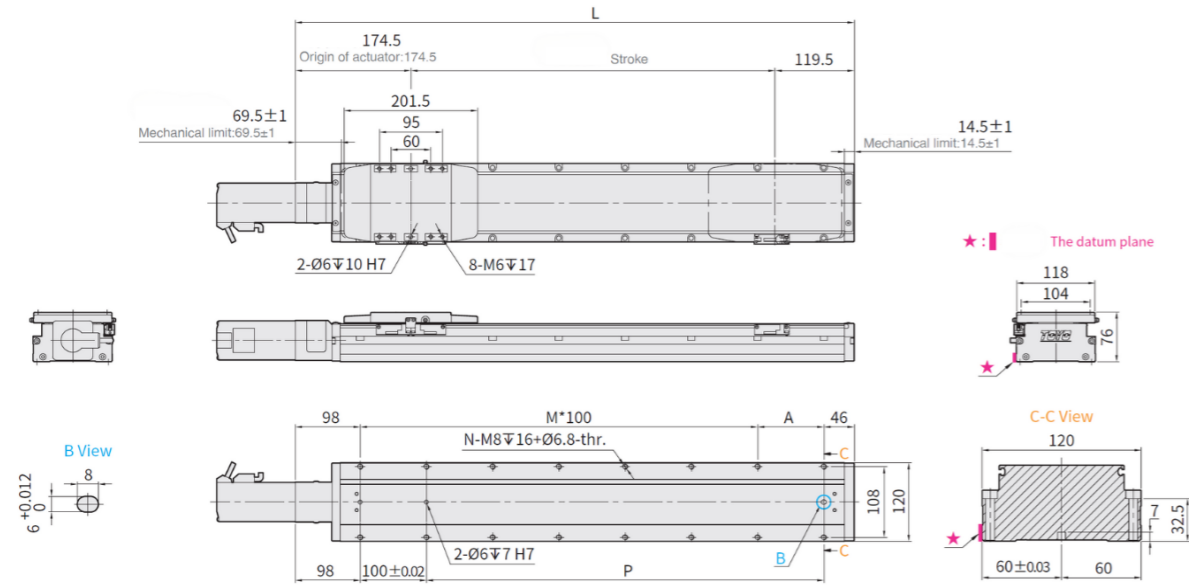

**BM GLTH12 - Motor Bottom Side**

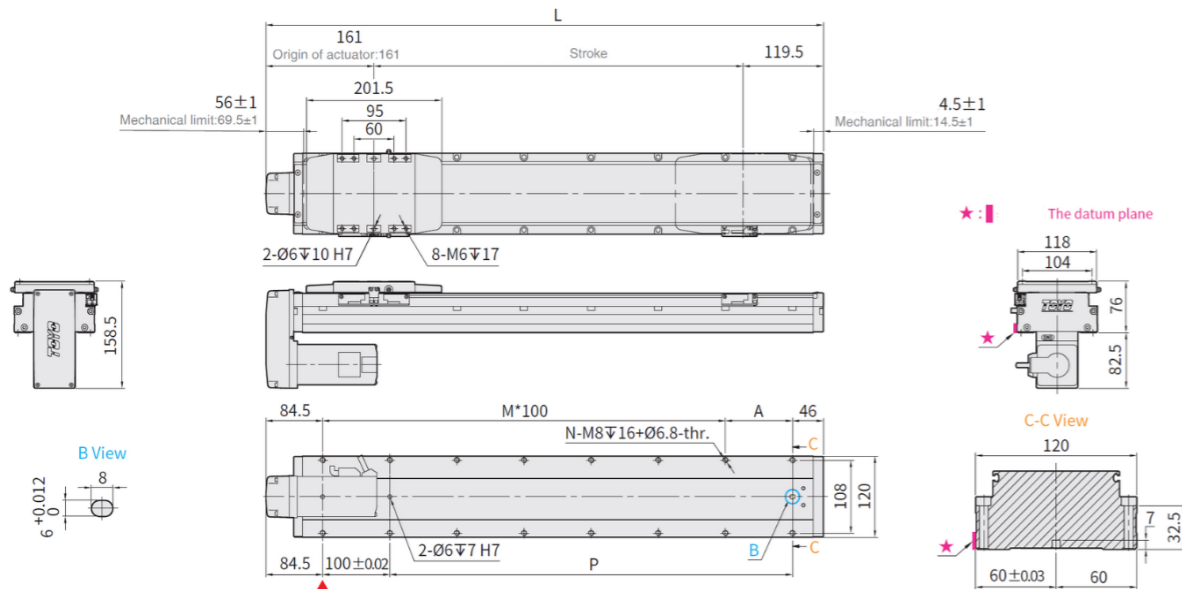

Please note that this thread hole will be covered by motor.

**BL GLTH12 - Motor Left Side**

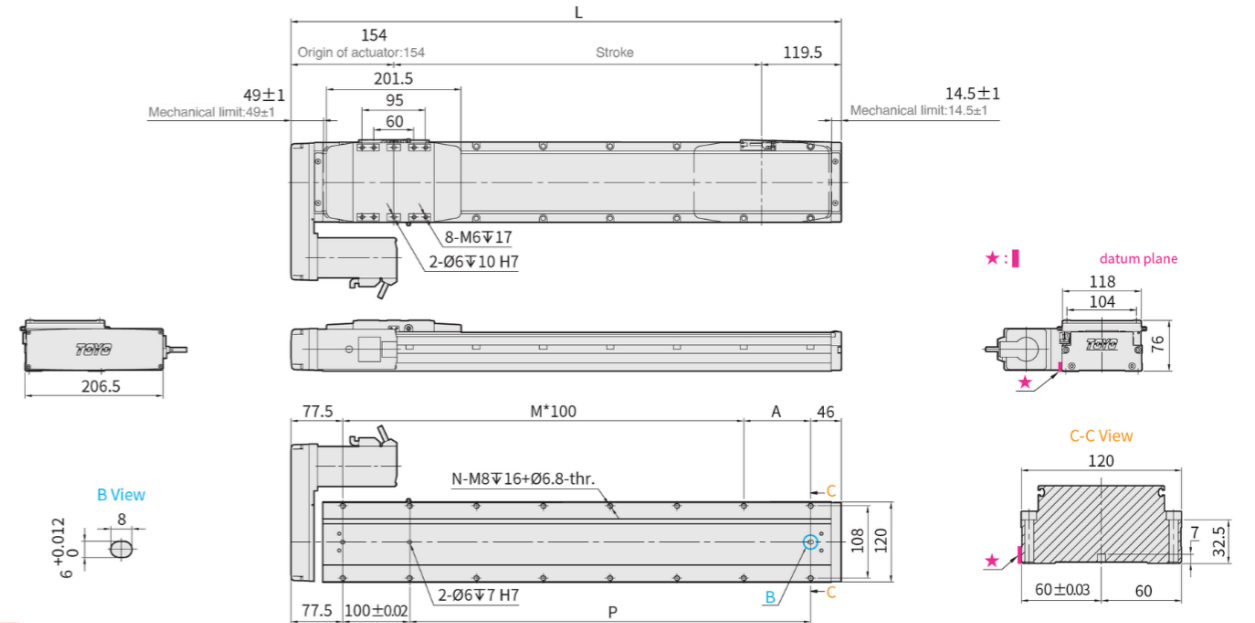

**BR GLTH12 - Motor Right Side**

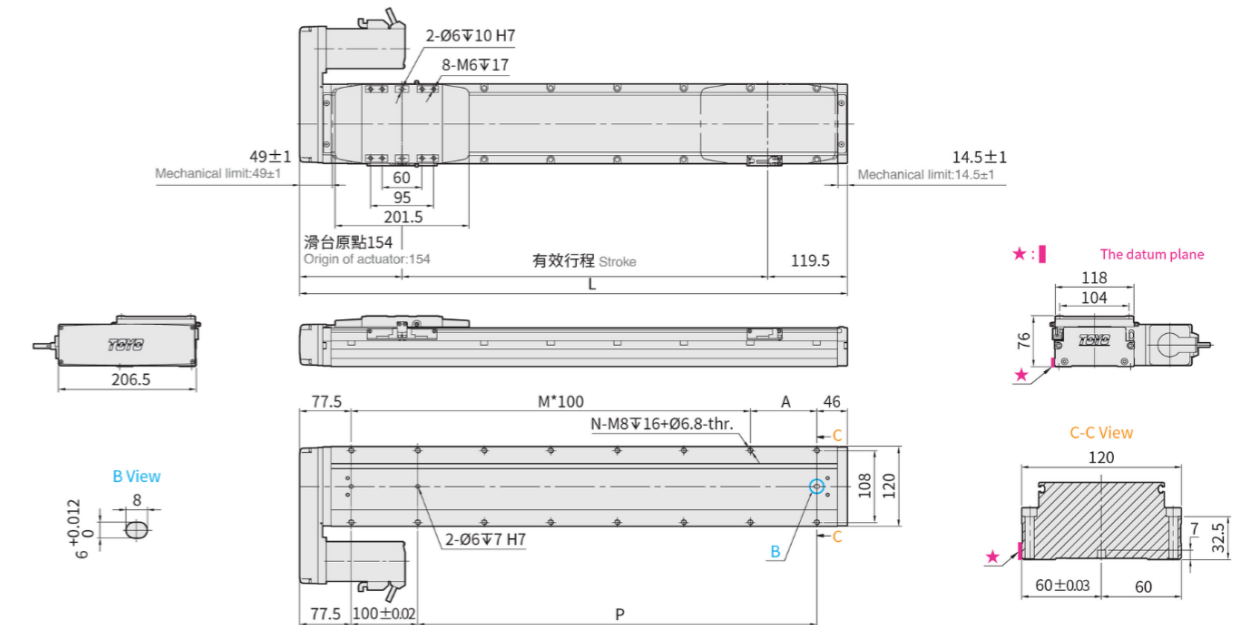

Stroke	50 <sup>-1</sup>	100	150	200	250	300	350	400	450	500	550	600	650	700	750	800	850	900	950	1000	1050	1100	1150	1200	1250								
Limit Stroke (±1)	58.5	108.5	158.5	208.5	258.5	308.5	358.5	408.5	458.5	508.5	558.5	608.5	658.5	708.5	758.5	808.5	858.5	908.5	958.5	1008.5	1058.5	1108.5	1158.5	1208.5	1258.5								
L	344	394	444	494	544	594	644	694	744	794	844	894	944	994	1044	1094	1144	1194	1244	1294	1344	1394	1444	1494	1544								
A	100	50	100	50	100	50	100	50	100	50	100	50	100	50	100	50	100	50	100	50	100	50	100	50	100								
M	1	2	2	3	3	4	4	5	5	6	6	7	7	8	8	9	9	10	10	11	11	12	12	13	13								
N	6	8	8	10	10	12	12	14	14	16	16	18	18	20	20	22	22	24	24	26	26	28	28	30	30								
KG	5.05	5.4	5.75	6.1	6.45	6.8	7.15	7.5	7.85	8.2	8.55	8.9	9.25	9.6	9.95	10.3	10.65	11	11.35	11.7	12.05	12.4	12.75	13.1	13.45								
Linear Speed mm/s	Lead 6	360										350										310	270	240	210	190	170	160	140	130	120	110	100
	Lead 12	720										700										620	540	480	420	380	340	320	280	260	240	220	200
	Lead 24	1440										1400										1240	1080	960	840	760	680	640	560	520	480	440	400
	Lead 6	360										350										310	270	240	210	190	170	160	140	130	120	110	100

When the stroke is 50 mm, fixing the body from top to bottom will cause the slider to block the fixing holes, allowing only 4 screws to be used. Therefore, it is recommended to fix the actuator body from bottom to top.

# GLTB5 - Belt driven



- Maximum Speed **1067 mm/s**
- Maximum Stroke **3000 mm**
- Max Payload **5 kg**

Specification			
Repeatability	mm	±0.06	
Lead (Perimeter on Drive Wheel)	mm	32	
Maximum Rotating Speed	rpm	2000	
Maximum linear speed	mm/s	1067	
Maximum Payload	Horizontal	kg	5
	Vertical	kg	-
Rated Thrust	N	53	
Stroke (Increments)	mm	50-3000mm/50 (50 increments)	
Maximum acceleration	G	0.27	
Belt Width	mm	9	

## Allowable Overhang

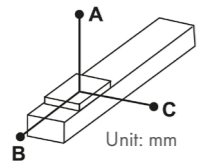

Horizontal Installation	A	B	C
2kg	622	64	65
3kg	380	36	38
5kg	168	14	15

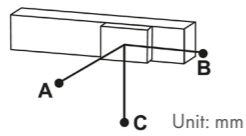

Wall Installation	A	B	C
2kg	65	64	622
3kg	38	36	380
5kg	15	14	168

## Static Loading Moment

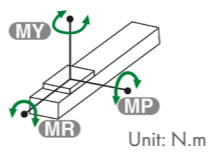

MY	73
MP	73
MR	115

The data presented in the moment table represents the center of gravity of the load. The overhang length is allowed in a single direction only. The operational life is 10,000 km when the product is used under the specified conditions. The provided data does not apply to ceiling-mounted inverse use. Please contact us for details if you intend to use the product in a ceiling-mounted inverse configuration. Life and torque values are calculated based on motor acceleration and deceleration times of 0.4 seconds.

## BW GLTB5 - Motor Top Side

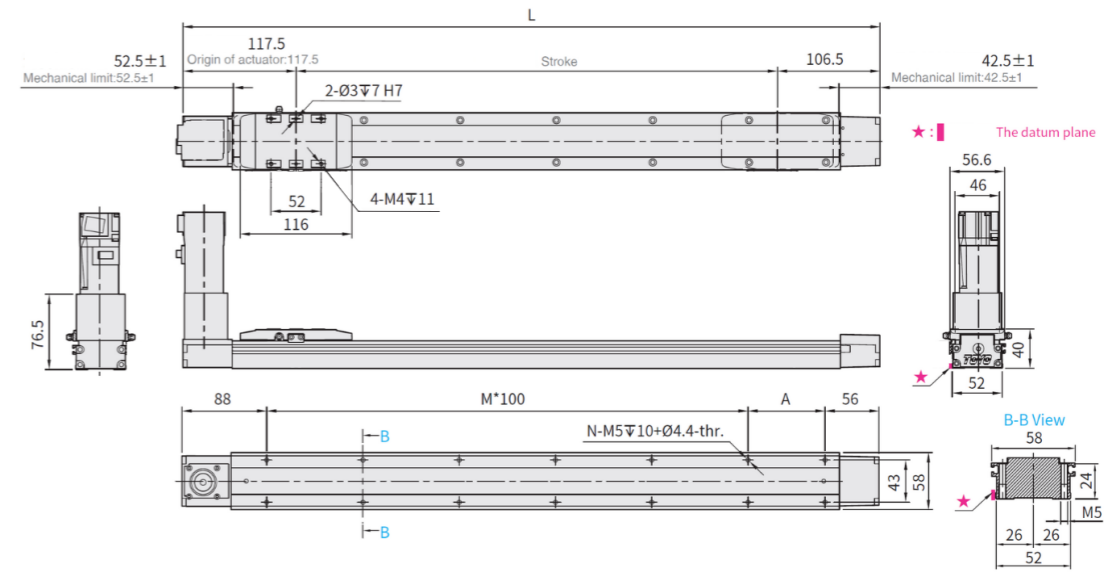

## BM GLTB5 - Motor Bottom

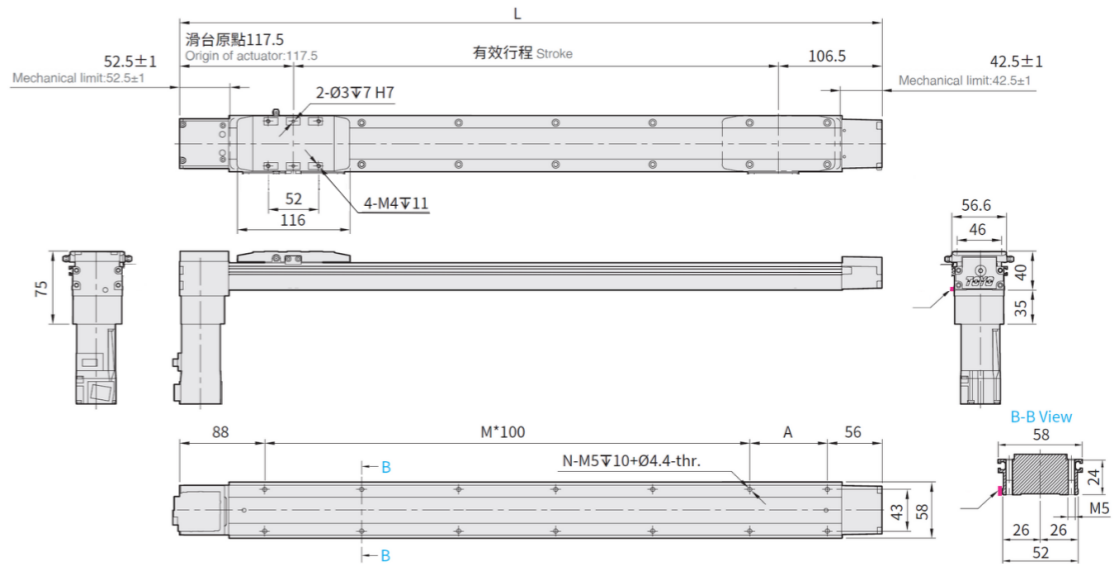

Stroke	50	100	150	200	250	300	350	400	450	500	550	600	650	700	750	800	850	900	950	1000	1050	1100	1150	1200	1250	1300	1350	1400	1450	1500		
Limit Stroke (±1)	63	113	163	213	263	313	363	413	463	513	563	613	663	713	763	813	863	913	963	1013	1063	1113	1163	1213	1263	1313	1363	1413	1463	1513		
L	274	324	374	424	474	524	574	624	674	724	774	824	874	924	974	1024	1074	1124	1174	1224	1274	1324	1374	1424	1474	1524	1574	1624	1674	1724		
A	30	80	30	80	30	80	30	80	30	80	30	80	30	80	30	80	30	80	30	80	30	80	30	80	30	80	30	80	30	80		
M	1	1	2	2	3	3	4	4	5	5	6	6	7	7	8	8	9	9	10	10	11	11	12	12	13	13	14	14	15	15		
N	6	6	8	8	10	10	12	12	14	14	16	16	18	18	20	20	22	22	24	24	26	26	28	28	30	30	32	32	34	34		
KG	1.56	1.6	1.64	1.68	1.72	1.76	1.8	1.84	1.88	1.92	1.95	1.99	2.03	2.07	2.11	2.14	2.18	2.22	2.26	2.29	2.33	2.37	2.41	2.44	2.48	2.52	2.56	2.59	2.63	2.67		
Linear Speed mm/s	1067																															

Stroke	1550	1600	1650	1700	1750	1800	1850	1900	1950	2000	2050	2100	2150	2200	2250	2300	2350	2400	2450	2500	2550	2600	2650	2700	2750	2800	2850	2900	2950	3000		
Limit Stroke (±1)	1563	1613	1663	1713	1763	1813	1863	1913	1963	2013	2063	2113	2163	2213	2263	2313	2363	2413	2463	2513	2563	2613	2663	2713	2763	2813	2863	2913	2963	3013		
L	1774	1824	1874	1924	1974	2024	2074	2124	2174	2224	2274	2324	2374	2424	2474	2524	2574	2624	2674	2724	2774	2824	2874	2924	2974	3024	3074	3124	3174	3224		
A	30	80	30	80	30	80	30	80	30	80	30	80	30	80	30	80	30	80	30	80	30	80	30	80	30	80	30	80	30	80		
M	16	16	17	17	18	18	19	19	20	20	21	21	22	22	23	23	24	24	25	25	26	26	27	27	28	28	29	29	30	30		
N	36	36	38	38	40	40	42	42	44	44	46	46	48	48	50	50	52	52	54	54	56	56	58	58	60	60	62	62	64	64		
KG	2.71	2.74	2.77	2.81	2.85	2.89	2.93	2.96	3	3.04	3.08	3.11	3.15	3.19	3.23	3.26	3.3	3.34	3.38	3.41	3.45	3.49	3.53	3.56	3.6	3.63	3.67	3.71	3.75	3.78		
Linear Speed mm/s	1067																															

# GLTB8 - Belt driven



- Maximum Speed  
**2000 mm/s**
- Maximum Stroke  
**3000 mm**
- Max Payload  
**8 kg**

Specification			
Repeatability	mm	±0.06	
Lead (Perimeter on Drive Wheel)	mm	60	
Maximum Rotating Speed	rpm	2000	
Maximum linear speed	mm/s	2000	
Maximum Payload	Horizontal	kg	8
	Vertical	kg	-
Rated Thrust	N	116	
Stroke (Increments)	mm	50-3000mm/50 (50 increments)	
Maximum acceleration	G	0.51	
Belt Width	mm	8	

## Allowable Overhang



Horizontal Installation	A	B	C	Wall Installation	A	B	C
2kg	1110	126	132	2kg	132	126	1110
5kg	427	90	94	5kg	94	90	427
8kg	256	73	77	8kg	77	73	256

## Static Loading Moment

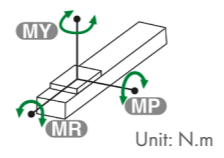

MY	137
MP	137
MR	227

The data presented in the moment table represents the center of gravity of the load. The overhang length is allowed in a single direction only. The operational life is 10,000 km when the product is used under the specified conditions. The provided data does not apply to ceiling-mounted inverse use. Please contact us for details if you intend to use the product in a ceiling-mounted inverse configuration. Life and torque values are calculated based on motor acceleration and deceleration times of 0.4 seconds.

# BW GLTB8 - Motor Top Side

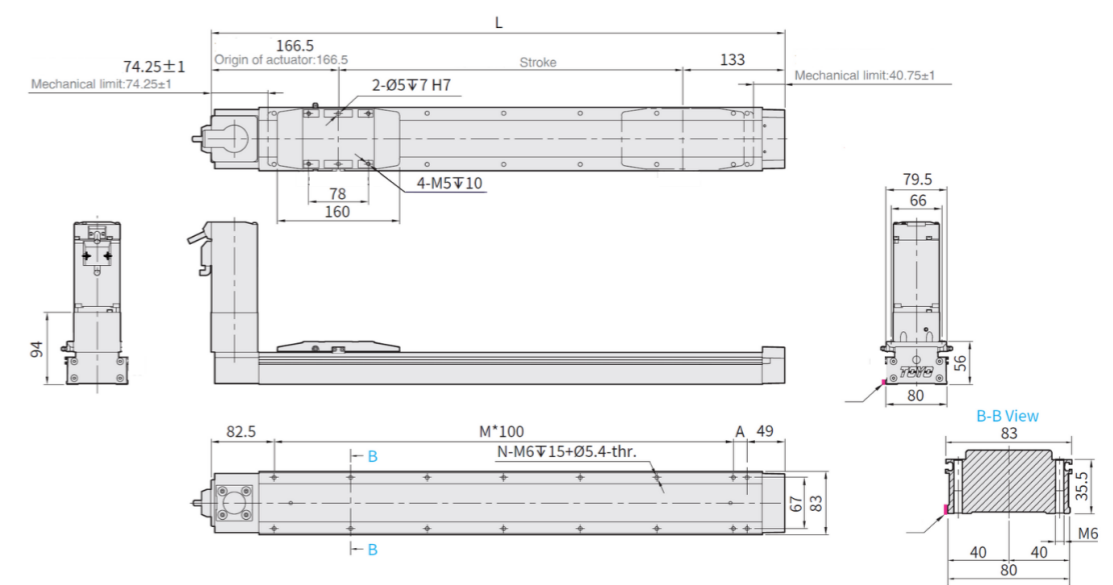

# BM GLTB8 - Motor Bottom Side

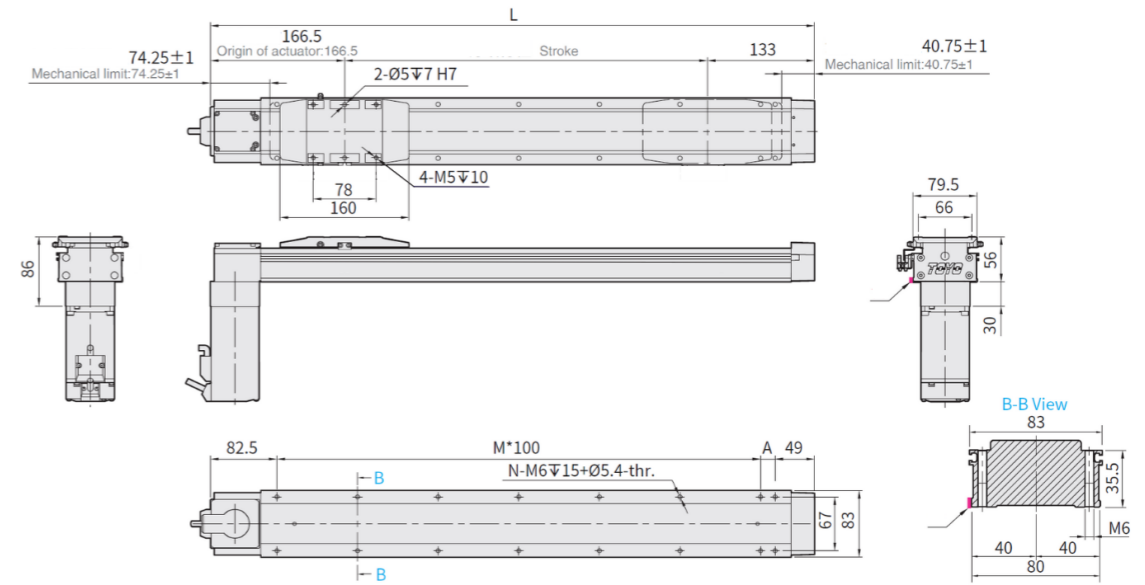

Stroke	50	100	150	200	250	300	350	400	450	500	550	600	650	700	750	800	850	900	950	1000	1050	1100	1150	1200	1250	1300	1350	1400	1450	1500		
Limit Stroke (±1)	74.5	124.5	174.5	224.5	274.5	324.5	374.5	424.5	474.5	524.5	574.5	624.5	674.5	724.5	774.5	824.5	874.5	924.5	974.5	1024.5	1074.5	1124.5	1174.5	1224.5	1274.5	1324.5	1374.5	1424.5	1474.5	1524.5		
L	349.5	399.5	449.5	499.5	549.5	599.5	649.5	699.5	749.5	799.5	849.5	899.5	949.5	999.5	1049.5	1099.5	1149.5	1199.5	1249.5	1299.5	1349.5	1399.5	1449.5	1499.5	1549.5	1599.5	1649.5	1699.5	1749.5	1799.5		
A	18	68	18	68	18	68	18	68	18	68	18	68	18	68	18	68	18	68	18	68	18	68	18	68	18	68	18	68	18	68		
M	2	2	3	3	4	4	5	5	6	6	7	7	8	8	9	9	10	10	11	11	12	12	13	13	14	14	15	15	16	16		
N	8	8	10	10	12	12	14	14	16	16	18	18	20	20	22	22	24	24	26	26	28	28	30	30	32	32	34	34	36	36		
KG	2.52	2.73	2.94	3.15	3.36	3.57	3.78	3.99	4.2	4.41	4.62	4.83	5.04	5.25	5.46	5.67	5.88	6.09	6.3	6.51	6.72	6.93	7.14	7.35	7.56	7.77	7.98	8.19	8.4	8.61		
Linear Speed mm/s	2000																															

Stroke	1550	1600	1650	1700	1750	1800	1850	1900	1950	2000	2050	2100	2150	2200	2250	2300	2350	2400	2450	2500	2550	2600	2650	2700	2750	2800	2850	2900	2950	3000		
Limit Stroke (±1)	1574.5	1624.5	1674.5	1724.5	1774.5	1824.5	1874.5	1924.5	1974.5	2024.5	2074.5	2124.5	2174.5	2224.5	2274.5	2324.5	2374.5	2424.5	2474.5	2524.5	2574.5	2624.5	2674.5	2724.5	2774.5	2824.5	2874.5	2924.5	2974.5	3024.5		
L	1849.5	1899.5	1949.5	1999.5	2049.5	2099.5	2149.5	2199.5	2249.5	2299.5	2349.5	2399.5	2449.5	2499.5	2549.5	2599.5	2649.5	2699.5	2749.5	2799.5	2849.5	2899.5	2949.5	2999.5	3049.5	3099.5	3149.5	3199.5	3249.5	3299.5		
A	18	68	18	68	18	68	18	68	18	68	18	68	18	68	18	68	18	68	18	68	18	68	18	68	18	68	18	68	18	68		
M	17	17	18	18	19	19	20	20	21	21	22	22	23	23	24	24	25	25	26	26	27	27	28	28	29	29	30	30	31	31		
N	38	38	40	40	42	42	44	44	46	46	48	48	50	50	52	52	54	54	56	56	58	58	60	60	62	62	64	64	66	66		
KG	8.82	9.03	9.24	9.45	9.66	9.87	10.08	10.29	10.5	10.71	10.92	11.13	11.34	11.55	11.76	11.97	12.18	12.39	12.6	12.81	13.02	13.23	13.44	13.65	13.86	14.07	14.28	14.49	14.7	14.91		
Linear Speed mm/s	1067																															

# GLTH5D - Ball screw



- Maximum Speed 1200 mm/s
- Maximum Stroke 850 mm
- Max Payload 30 kg

Specification						
Repeatability	mm	±0.005				
Lead (Perimeter on Drive Wheel)	mm	2	6	12	20	
Maximum Rotating Speed	rpm	3600	3600	3600	3600	
Maximum linear speed	mm/s	120	300	720	1200	
Maximum Payload	Horizontal	kg	30	25	22	10
	Vertical	kg	10	6	4	3
Rated Thrust	N	854	285	142	85	
Stroke (Increments)	mm	50-850mm/50 (50 increments)				
Maximum acceleration	G	0.12	0.37	0.73	1.22	
Ball screw	Basic dynamic load rating Ca	N	2270	2243	1436	1384
	Basic static load rating Coa	N	4836	3959	2441	2535
Linear Guide	Dynamic horizontal (100km)	N	6563			
	Static Horizontal	N	13587			
Fixed bearing	Basic dynamic load rating Cr	N	5361			
	Static load rating Cor	N	2880			
Ball screw Ø	mm	C7Ø10				
Coupling	mm	7X8				

During long strokes, ballscrew deflection can occur, so the speed must be reduced (refer to the linear velocity in the data sheet below the dimension graph).

## Allowable Overhang

Horizontal Installation				Wall Installation				Vertical Installation			
Lead	Weight	A	B	Lead	Weight	A	B	Lead	Weight	A	C
2	10kg	2500	157	250	10kg	250	157	2500	5kg	346	346
	20kg	1120	70	112	20kg	112	70	1120	10kg	173	173
	30kg	650	41	65	30kg	65	41	650	-	-	-
6	10kg	1400	122	1400	10kg	184	122	1400	3kg	463	463
	20kg	650	52	79	20kg	79	52	650	6kg	231	231
	25kg	490	38	57	25kg	57	38	490	-	-	-
12	8kg	590	132	175	8kg	175	132	590	2.5kg	465	465
	10kg	460	103	135	10kg	135	103	460	4kg	292	292
	22kg	185	37	49	22kg	49	37	185	-	-	-
20	3kg	656	300	303	3kg	303	300	656	1.5kg	555	555
	6kg	314	141	144	6kg	144	141	314	3kg	278	278
	10kg	177	78	79	10kg	79	78	177	-	-	-

## Static Loading Moment

Moment	Value (N.m)
MY	73
MP	73
MR	115

The data presented in the moment table represents the center of gravity of the load. The overhang length is allowed in a single direction only. The operational life is 10,000 km when the product is used under the specified conditions. The provided data does not apply to ceiling-mounted inverse use. Please contact us for details if you intend to use the product in a ceiling-mounted inverse configuration. Life and torque values are calculated based on motor acceleration and deceleration times of 0.2 seconds.

## BC GLTH5D - Motor Exposed

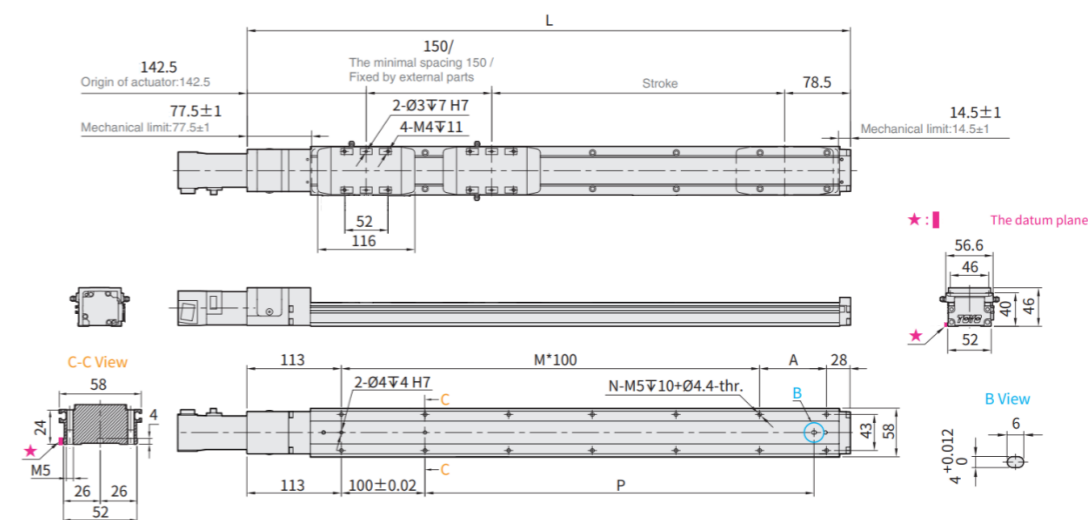

## BM GLTH5D - Motor Bottom Side

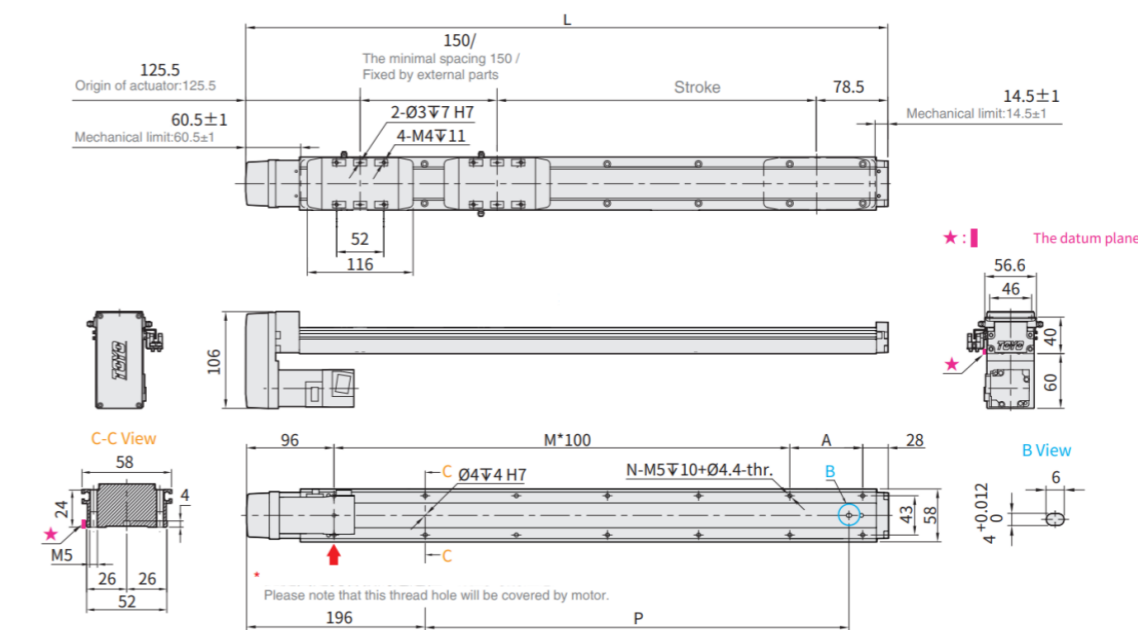

Stroke	50	100	150	200	250	300	350	400	450	500	550	600	650	700	750	800	850
Limit Stroke (±1)	63	113	163	213	263	313	363	413	463	513	563	613	663	713	763	813	863
L	402	452	502	552	602	652	702	752	802	852	902	952	1002	1052	1102	1152	1202
A	80	30	80	30	80	30	80	30	80	30	80	30	80	30	80	30	80
M	2	3	3	4	4	5	5	6	6	7	7	8	8	9	9	10	10
N	8	10	10	12	12	14	14	16	16	18	18	20	20	22	22	24	24
P	165	215	265	315	365	415	465	515	565	615	665	715	765	815	865	915	965
KG	1.67	1.8	1.92	2.05	2.18	2.3	2.43	2.56	2.68	2.81	2.94	3.06	3.19	3.31	3.44	3.57	3.69
Linear Speed mm/s	Lead 2	120						110	90	80	70	63	53	50	43	40	36
	Lead 6	360						330	270	240	210	190	160	150	130	120	110
	Lead 12	720						660	540	480	420	380	320	300	260	240	220
	Lead 20	1200						1100	900	800	700	633	530	500	433	400	367

When the stroke is 50 mm, fixing the body from top to bottom will cause the slider to block the fixing holes, allowing only 4 screws to be used. Therefore, it is recommended to fix the actuator body from bottom to top.

**BL GLTH5D - Motor Left Side**

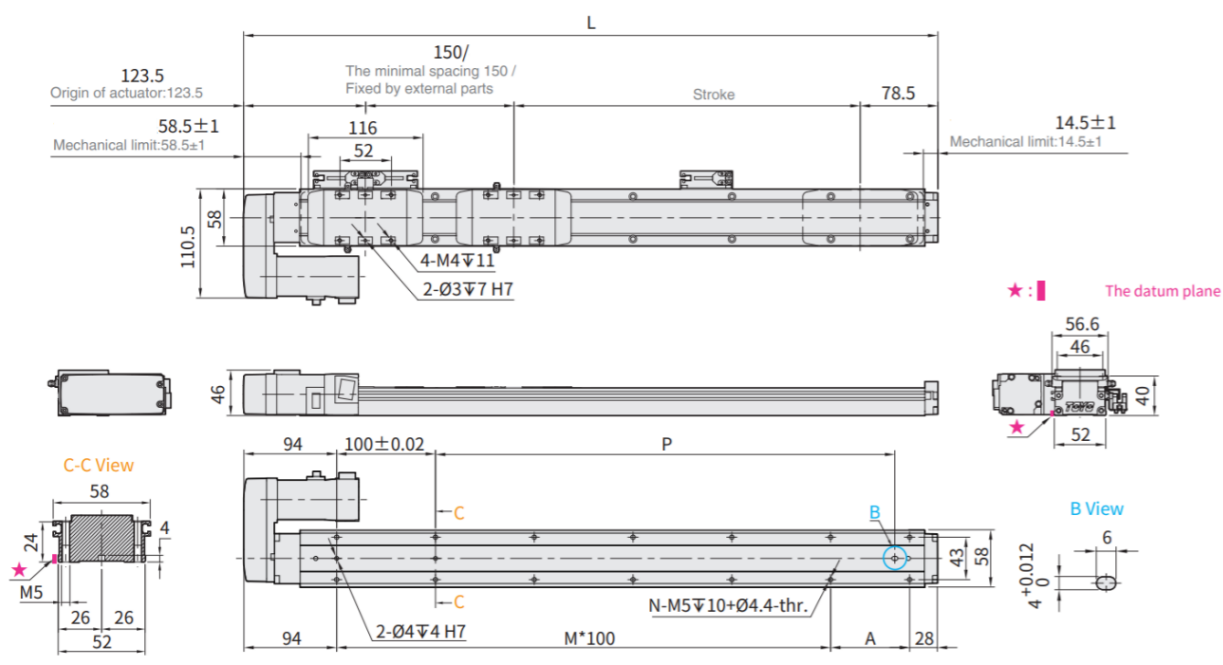

**BR GLTH5D - Motor Right Side**

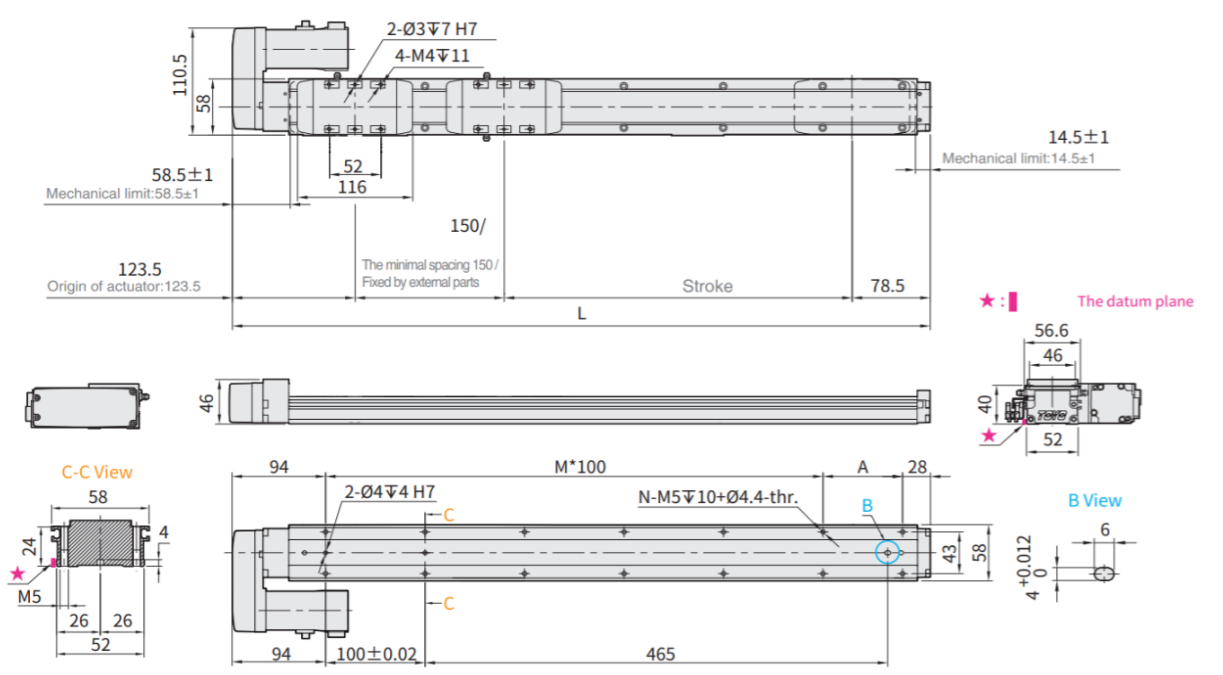

Stroke	50 <sup>±1</sup>	100	150	200	250	300	350	400	450	500	550	600	650	700	750	800	850
Limit Stroke (±1)	63	113	163	213	263	313	363	413	463	513	563	613	663	713	763	813	863
L	402	452	502	552	602	652	702	752	802	852	902	952	1002	1052	1102	1152	1202
A	80	30	80	30	80	30	80	30	80	30	80	30	80	30	80	30	80
M	2	3	3	4	4	5	5	6	6	7	7	8	8	9	9	10	10
N	8	10	10	12	12	14	14	16	16	18	18	20	20	22	22	24	24
P	165	215	265	315	365	415	465	515	565	615	665	715	765	815	865	915	965
KG	1.67	1.8	1.92	2.05	2.18	2.3	2.43	2.56	2.68	2.81	2.94	3.06	3.19	3.31	3.44	3.57	3.69
Linear Speed mm/s	Lead 2	120															
	Lead 6	360															
	Lead 12	720															
	Lead 20	1200															

When the stroke is 50 mm, fixing the body from top to bottom will cause the slider to block the fixing holes, allowing only 4 screws to be used. Therefore, it is recommended to fix the actuator body from bottom to top.

**GLTH8D - Ball screw**



- Maximum Speed **1440 mm/s**
- Maximum Stroke **1050 mm**
- Max Payload **80 kg**

Specification				
Repeatability	mm	±0.005		
Lead (Perimeter on Drive Wheel)	mm	6	12	24
Maximum Rotating Speed	rpm	3600	3600	3600
Maximum linear speed	mm/s	360	720	1440
Maximum Payload	Horizontal	kg	80	60
	Vertical	kg	15	8
Rated Thrust	N	569	284	142
Stroke (Increments)	mm	50-1050mm/50 (50 increments)		
Maximum acceleration	G	0.37	0.73	1.47
Ball screw	Basic dynamic load rating Ca	N	7733	5855
	Basic static load rating Coa	N	14200	10401
Linear Guide	Dynamic horizontal (100km)	N	18601	
	Static Horizontal	N	34189	
Fixed bearing	Basic dynamic load rating Cr	N	8447	
	Static load rating Cor	N	5060	
Ball screw Ø	mm	C7Ø14		
Coupling	mm	10X14/11 <sup>※3</sup>		

During long strokes, ballscrew deflection can occur, so the speed must be reduced (refer to the linear velocity in the data sheet below the dimension graph). Since the motor performance of each brand is different, a regenerative resistor needs to be appropriately matched to achieve this load condition.

**Allowable Overhang**

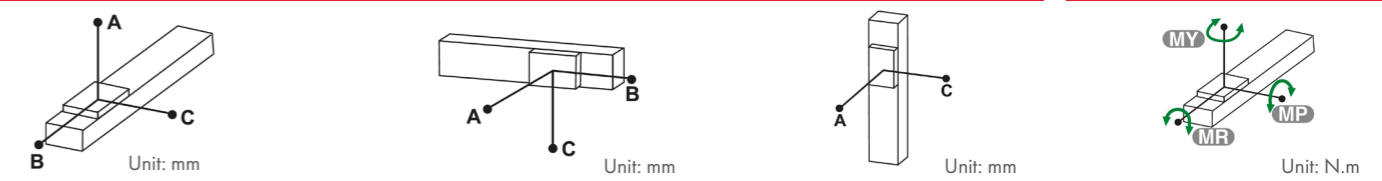

Horizontal Installation		A	B	C	Wall Installation		A	B	C	Vertical Installation		A	C
6 Lead	35kg	1600	139	220	6 Lead	35kg	220	139	1600	2 Lead	10kg	535	535
	45kg	1210	102	160		45kg	160	102	1210		15kg	360	360
	80kg	620	46	74		80kg	74	46	620		-	-	-
12 Lead	10kg	2040	470	645	12 Lead	10kg	645	470	2040	6 Lead	3.5kg	1380	1380
	30kg	638	141	193		30kg	193	141	638		8kg	605	605
	60kg	283	58	80		60kg	80	58	283		-	-	-
24 Lead	20kg	253	145	133	24 Lead	20kg	133	145	253	12 Lead	2kg	1380	1380
	40kg	109	60	55		40kg	55	60	109		5kg	556	556
	-	-	-	-		-	-	-	-		-	-	-

MY	137
MP	137
MR	227

The data presented in the moment table represents the center of gravity of the load. The overhang length is allowed in a single direction only. The operational life is 10,000 km when the product is used under the specified conditions. The provided data does not apply to ceiling-mounted inverse use. Please contact us for details if you intend to use the product in a ceiling-mounted inverse configuration. Life and torque values are calculated based on motor acceleration and deceleration times of 0.2 seconds.

**BC GLTH8D - Motor Exposed**

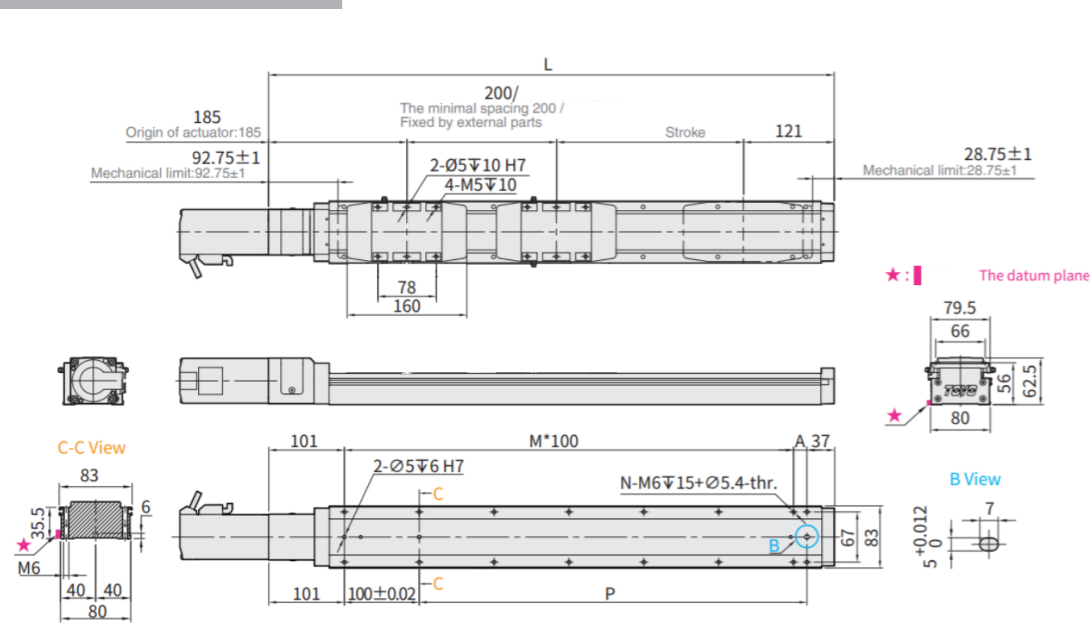

**BL GLTH8D - Motor Left Side**

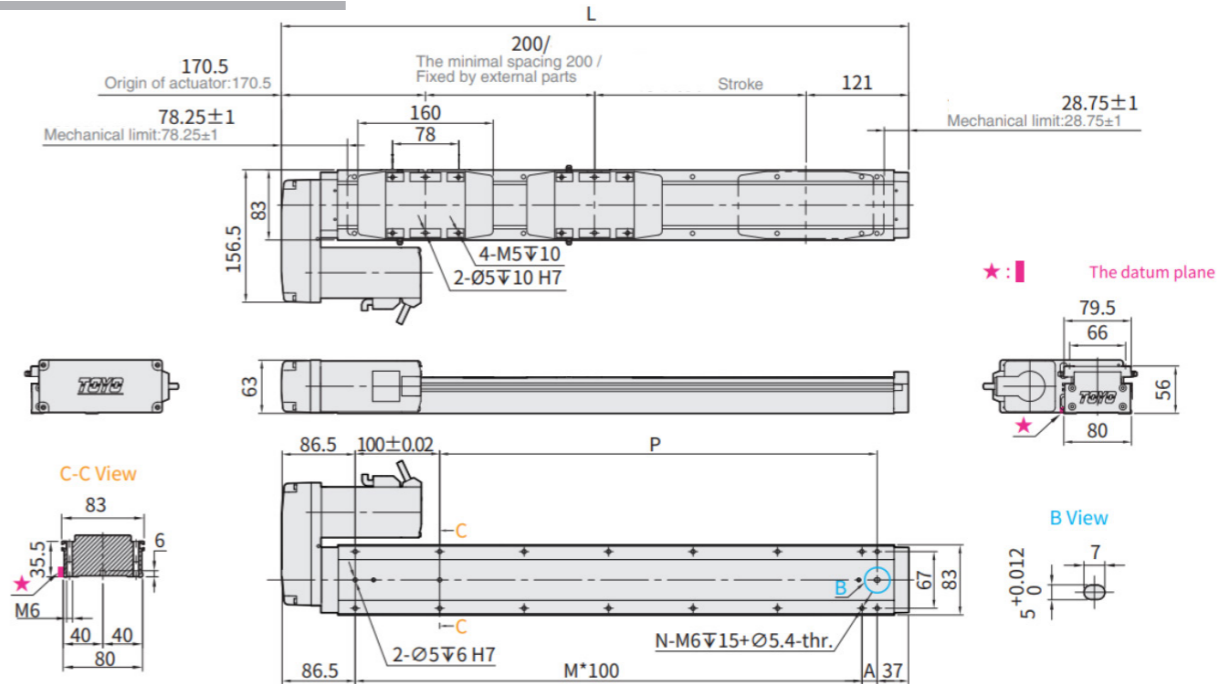

**BM GLTH8D - Motor Bottom Side**

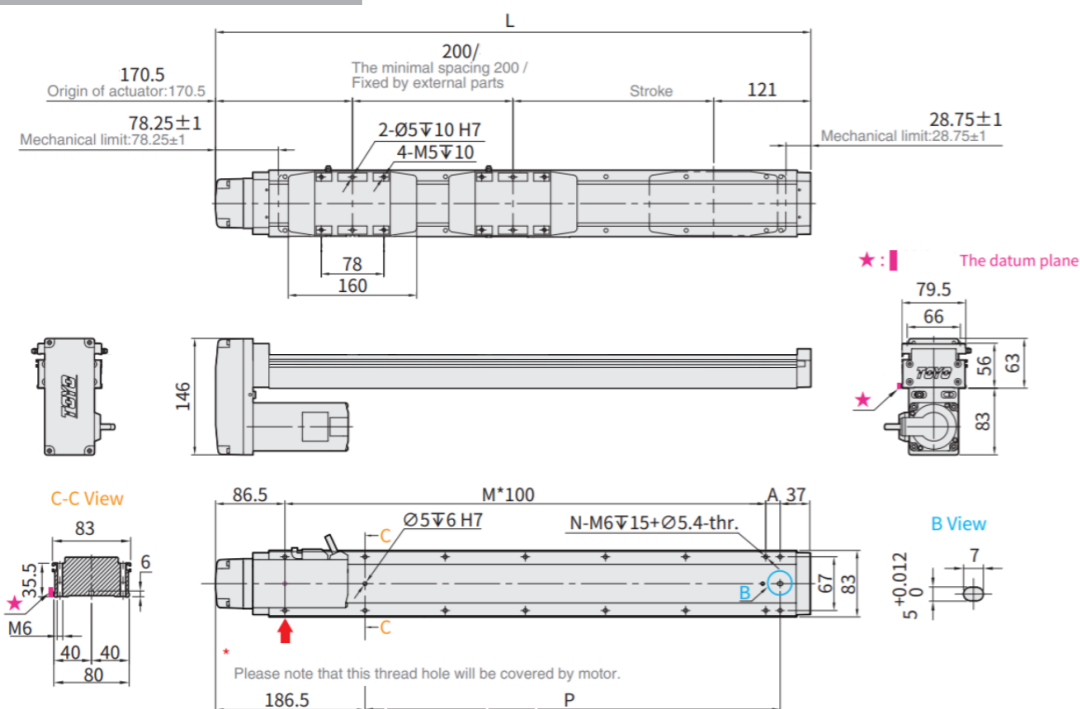

**BR GLTH8D - Motor Right Side**

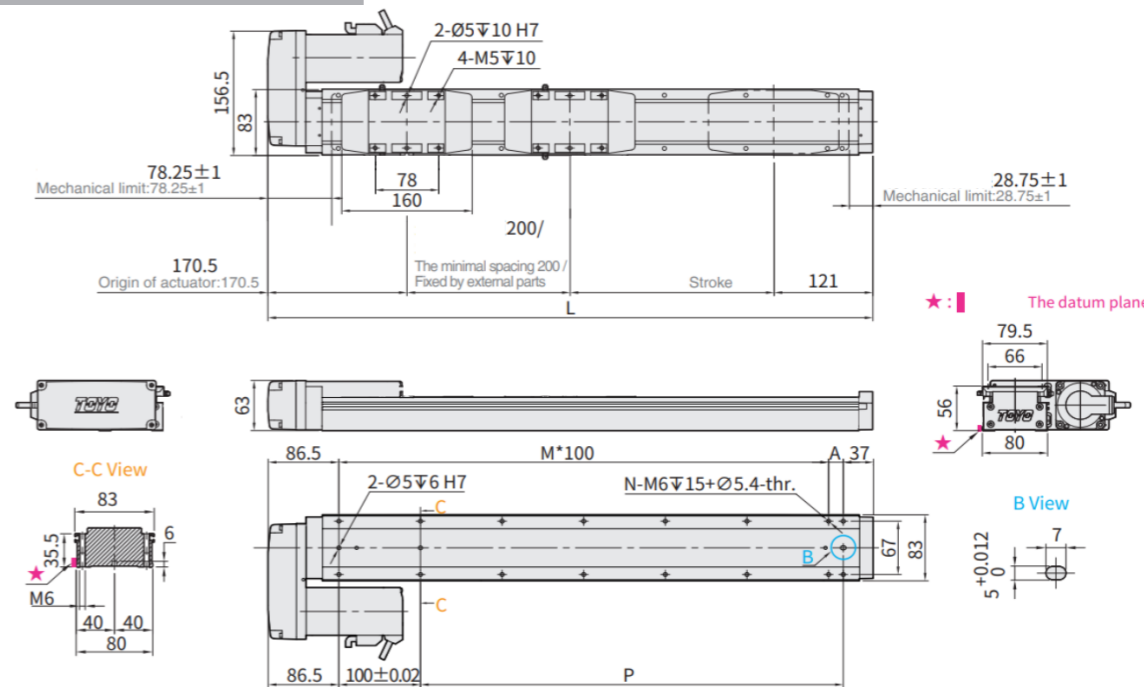

Stroke	50 <sup>-1</sup>	100	150	200	250	300	350	400	450	500	550	600	650	700	750	800	850	900	950	1000	1050	
Limit Stroke (±1)	74.5	124.5	174.5	224.5	274.5	324.5	374.5	424.5	474.5	524.5	574.5	624.5	674.5	724.5	774.5	824.5	874.5	924.5	974.5	1024.5	1074.5	
L	BC	556	606	656	706	756	806	856	906	956	1006	1056	1106	1156	1206	1256	1306	1356	1406	1456	1506	1556
	BM	541.5	591.5	641.5	691.5	741.5	791.5	841.5	891.5	941.5	991.5	1041.5	1091.5	1141.5	1191.5	1241.5	1291.5	1341.5	1391.5	1441.5	1491.5	1541.5
A	18	68	18	68	18	68	18	68	18	68	18	68	18	68	18	68	18	68	18	68	18	68
M	4	4	5	5	6	6	7	7	8	8	9	9	10	10	11	11	12	12	13	13	14	14
N	12	12	14	14	16	16	18	18	20	20	22	22	24	24	26	26	28	28	30	30	32	32
P	318	368	418	468	518	568	618	668	718	768	818	868	918	968	1018	1068	1118	1168	1218	1268	1318	1318
KG	BC	3.89	4.19	4.49	4.78	5.08	5.37	5.67	5.97	6.27	6.56	6.86	7.15	7.45	7.75	8.04	8.34	8.64	8.93	9.23	9.53	9.82
	BM	4.27	4.56	4.86	5.15	5.45	5.75	6.04	6.34	6.64	6.93	7.23	7.53	7.82	8.12	8.41	8.71	9.01	9.3	9.6	9.9	10.19
Linear Speed mm/s	Lead 6								350	310	270	240	210	190	170	160	140	130	120	110	100	90
	Lead 12								700	620	540	480	420	380	340	320	280	260	240	220	200	180
	Lead 24								1400	1240	1080	960	840	760	680	640	560	520	480	440	400	360

Stroke	50 <sup>-1</sup>	100	150	200	250	300	350	400	450	500	550	600	650	700	750	800	850	900	950	1000	1050	
Limit Stroke (±1)	74.5	124.5	174.5	224.5	274.5	324.5	374.5	424.5	474.5	524.5	574.5	624.5	674.5	724.5	774.5	824.5	874.5	924.5	974.5	1024.5	1074.5	
L	541.5	591.5	641.5	691.5	741.5	791.5	841.5	891.5	941.5	991.5	1041.5	1091.5	1141.5	1191.5	1241.5	1291.5	1341.5	1391.5	1441.5	1491.5	1541.5	
A	18	68	18	68	18	68	18	68	18	68	18	68	18	68	18	68	18	68	18	68	18	68
M	4	4	5	5	6	6	7	7	8	8	9	9	10	10	11	11	12	12	13	13	14	14
N	12	12	14	14	16	16	18	18	20	20	22	22	24	24	26	26	28	28	30	30	32	32
P	318	368	418	468	518	568	618	668	718	768	818	868	918	968	1018	1068	1118	1168	1218	1268	1318	1318
KG	4.27	4.56	4.86	5.15	5.45	5.75	6.04	6.34	6.64	6.93	7.23	7.53	7.82	8.12	8.41	8.71	9.08	9.3	9.6	9.9	10.19	10.19
Linear Speed mm/s	Lead 6										360											
	Lead 12										720											
	Lead 24										1440											

When the stroke is 50 mm, fixing the body from top to bottom will cause the slider to block the fixing holes, allowing only 4 screws to be used. Therefore, it is recommended to fix the actuator body from bottom to top.

# GLTH12D - Ball screw



Maximum Speed  
1440 mm/s

Maximum Stroke  
1040 mm

Max Payload  
110 kg

Specification				
Repeatability	mm	±0.005		
Lead (Perimeter on Drive Wheel)	mm	6	12	24
Maximum Rotating Speed	rpm	3600		
Maximum linear speed *1 *2	mm/s	360	720	1440
Maximum Payload	Horizontal	kg	110	88
	Vertical	kg	30	20
	Vertical with regenerative resistor	kg	-	-
Rated Thrust	N	1156	578	289
Stroke (Increments)	mm	40-1040mm/50		
Maximum acceleration	G	0.37	0.73	1.47
Ball screw	Basic dynamic load rating Ca	N	7733	5855
	Basic static load rating Coa	N	14200	10401
Linear Guide	Dynamic horizontal (100km)	N	51128	
	Static Horizontal	N	84518	
Fixed bearing	Basic dynamic load rating Cr	N	8447	
	Static load rating Cor	N	5060	
AC Servo Motor Output	W	400		
Ball screw Ø	mm	C7Ø14		
Coupling	mm	10x14		

During long strokes, ballscrew deflection can occur, so the speed must be reduced (refer to the linear velocity in the data sheet below the dimension graph).

## Allowable Overhang

## Static Loading Moment

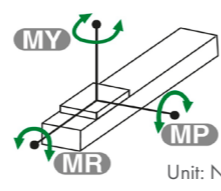
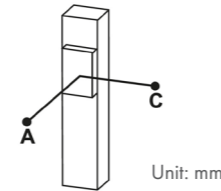
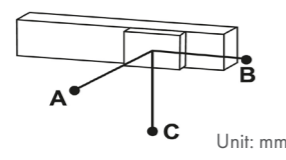
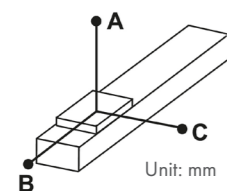

Horizontal Installation				Wall Installation				Vertical Installation						
	A	B	C		A	B	C		A	C				
6 Lead	60kg	1990	165	268	6 Lead	60kg	268	165	1990	6 Lead	20kg	1250	1250	
	80kg	1428	113	184		80kg	184	113	1428		12 Lead	30kg	830	830
	110kg	963	70	114		110kg	114	70	963			10kg	2250	2250
12 Lead	60kg	1538	346	483	12 Lead	60kg	483	346	1538	24 Lead	20kg	1120	1120	
	70kg	1300	290	406		70kg	406	290	1300		7kg	1840	1840	
	88kg	1010	222	311		88kg	311	222	1010		10kg	1280	1280	
24 Lead	20kg	1285	753	693	24 Lead	20kg	693	753	1285					
	30kg	835	487	450		30kg	450	487	835					
	40kg	613	355	328		40kg	328	355	613					

MY	606
MP	606
MR	1168

The data presented in the moment table represents the center of gravity of the load. The overhang length is allowed in a single direction only. The operational life is 10,000 km when the product is used under the specified conditions. The provided data does not apply to ceiling-mounted inverse use. Please contact us for details if you intend to use the product in a ceiling-mounted inverse configuration. Life and torque values are calculated based on motor acceleration and deceleration times of 0.2 seconds.

## BC GLTH12D - Motor Exposed

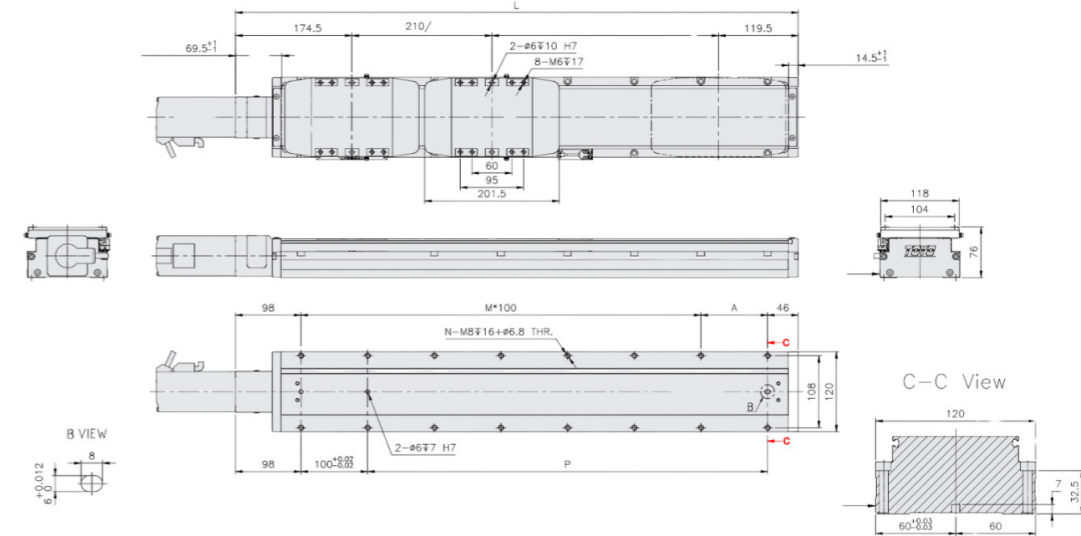

## BM GLTH12D - Motor Bottom Side

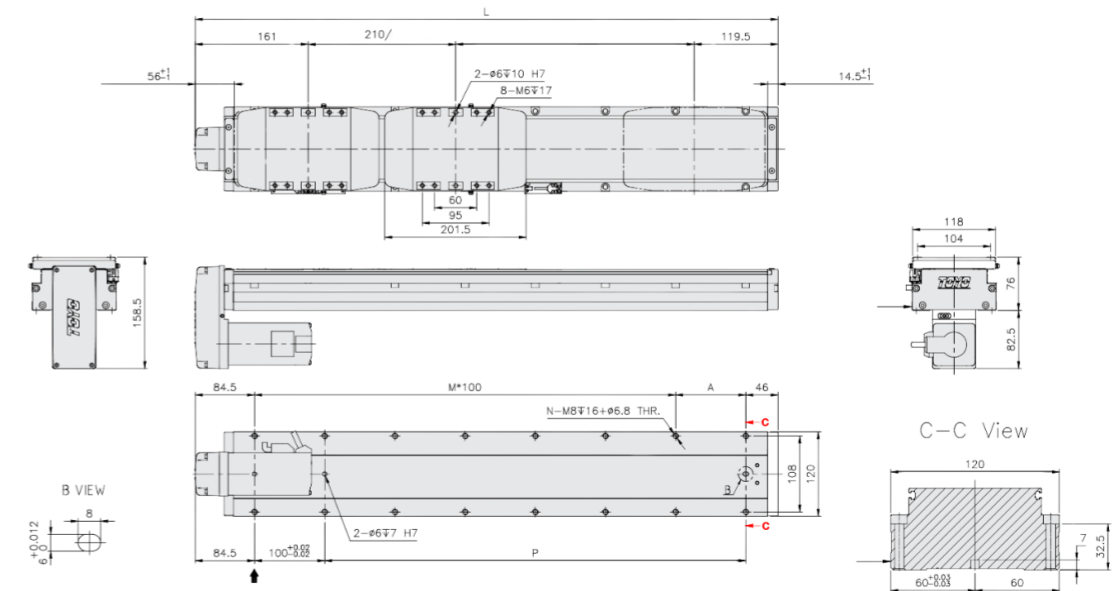

Stroke	40	90	140	190	240	290	340	390	440	490	540	590	640	690	740	790	840	890	940	990	1040			
Limit Stroke (±1)	48.5	98.5	148.5	198.5	248.5	298.5	348.5	398.5	448.5	498.5	548.5	598.5	648.5	698.5	748.5	798.5	848.5	898.5	948.5	998.5	1048.5			
L	BC	544	594	644	694	744	794	844	894	944	994	1044	1094	1144	1194	1244	1294	1344	1394	1444	1494	1544		
	BM	530.5	580.5	630.5	680.5	730.5	780.5	830.5	880.5	930.5	980.5	1030.5	1080.5	1130.5	1180.5	1230.5	1280.5	1330.5	1380.5	1430.5	1480.5	1530.5		
A	100	50	100	50	100	50	100	50	100	50	100	50	100	50	100	50	100	50	100	50	100	50		
M	3	4	4	5	5	6	6	7	7	8	8	9	9	10	10	11	11	12	12	12	13	13		
N	10	12	12	14	14	16	16	18	18	20	20	22	22	24	24	26	26	28	28	30	30	30		
P	300	350	400	450	500	550	600	650	700	750	800	850	900	950	1000	1050	1100	1150	1200	1250	1300			
KG	BC	8.26	8.61	8.96	9.31	9.66	10.01	10.36	10.71	11.06	11.41	11.76	12.11	12.46	12.81	13.16	13.51	13.86	14.21	14.56	14.91	15.26		
	BM	8.42	8.77	9.12	9.47	9.82	10.17	10.52	10.87	11.22	11.57	11.92	12.27	12.62	12.97	13.32	13.67	14.02	14.37	14.72	15.07	15.42		
Linear Speed mm/s	Lead 6	360										350	310	270	240	210	190	170	160	140	130	120	110	100
	Lead 12	720										700	620	540	480	420	380	340	320	280	260	240	220	200
	Lead 24	1440										1400	1240	1080	960	840	760	680	640	560	520	480	440	400

When the stroke is 50 mm, fixing the body from top to bottom will cause the slider to block the fixing holes, allowing only 4 screws to be used. Therefore, it is recommended to fix the actuator body from bottom to top.

**BL GLTH12D - Motor Left Side**

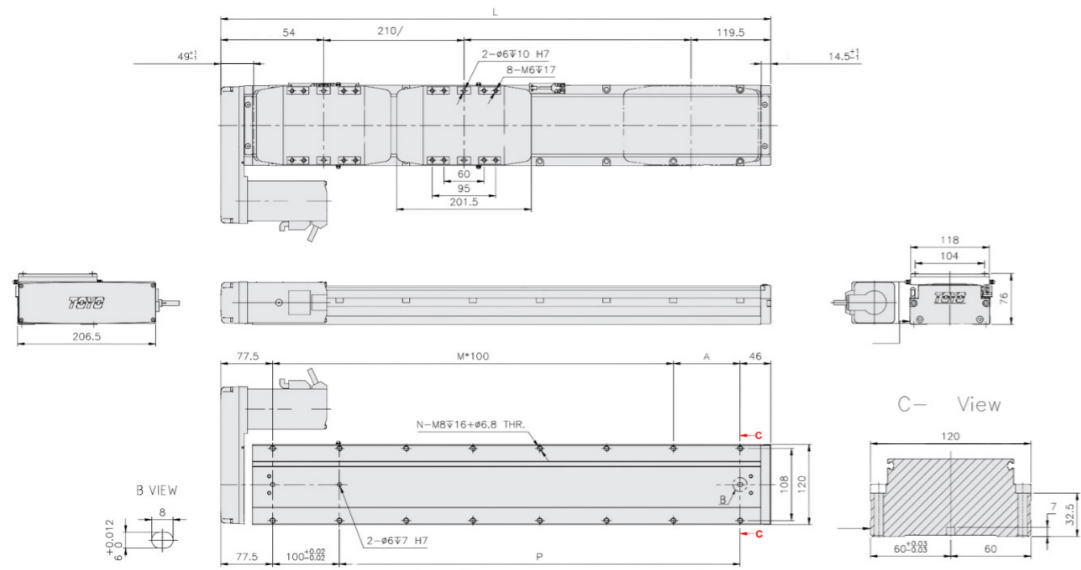

**BR GLTH12D - Motor Right Side**

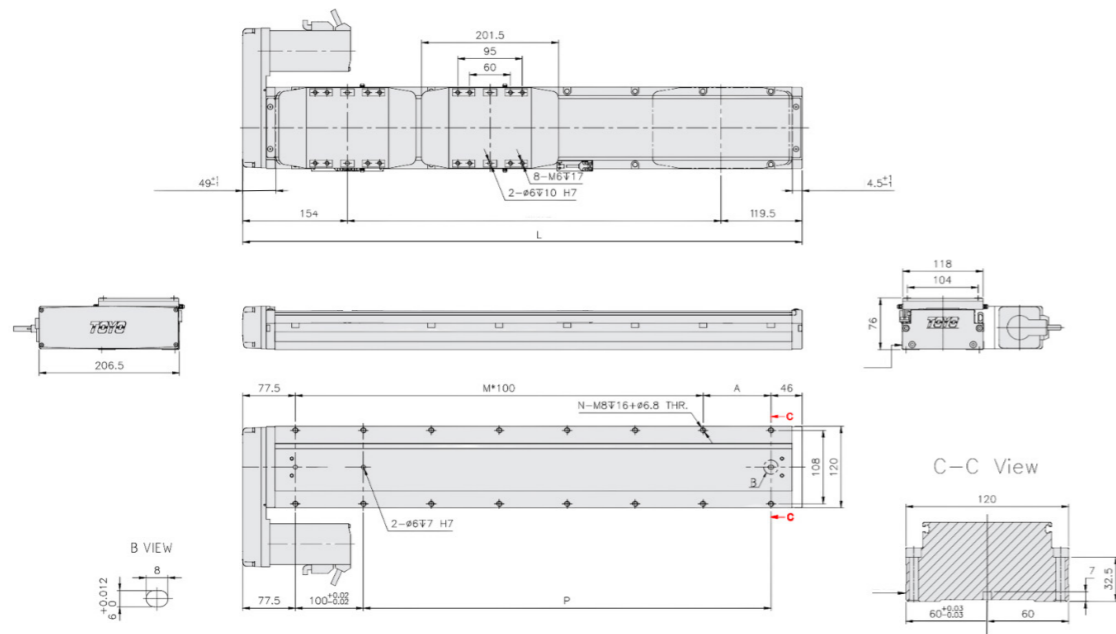

Stroke	40 <sup>±2</sup>	90 <sup>±2</sup>	140	190	240	290	340	390	440	490	540	590	640	690	740	790	840	890	940	990	1040	
Limit Stroke (±1)	48.5	98.5	148.5	198.5	248.5	298.5	348.5	398.5	448.5	498.5	548.5	598.5	648.5	698.5	748.5	798.5	848.5	898.5	948.5	998.5	1048.5	
L	523.5	573.5	623.5	673.5	723.5	773.5	823.5	873.5	923.5	973.5	1023.5	1073.5	1123.5	1173.5	1223.5	1273.5	1323.5	1373.5	1423.5	1473.5	1523.5	
A	100	50	100	50	100	50	100	50	100	50	100	50	100	50	100	50	100	50	100	50	100	
M	3	4	4	5	5	6	6	7	7	8	8	9	9	10	10	11	11	12	12	13	13	
N	10	12	12	14	14	16	16	18	18	20	20	22	22	24	24	26	26	28	28	30	30	
P	300	350	400	450	500	550	600	650	700	750	800	850	900	950	1000	1050	1100	1150	1200	1250	1300	
KG	8.46	8.81	9.16	9.51	9.86	10.21	10.56	10.91	11.26	11.61	11.96	12.31	12.66	13.01	13.36	13.71	14.06	14.41	14.76	15.11	15.46	
Linear Speed mm/s	Lead 6											360										
	Lead 12											720										
	Lead 24											1440										

When the stroke is 50 mm, fixing the body from top to bottom will cause the slider to block the fixing holes, allowing only 4 screws to be used. Therefore, it is recommended to fix the actuator body from bottom to top.

**Article numbers for the Linear Modules**

**Linear Modules**

**GLTH 5 - D-200 - L6 - 500 - BC - CP7/8 - HG-KR43**

GLTH = Ballscrew Driven, GLTB = Belt Driven

Size of Linear module 3,5,8,12

Number of Carriage. No symbol = 1 Carriage D= 2 Carriages + CC Measurement

Ball Screw Lead

Stroke on Linear module incl overlap

Motorposition BC = Motor Exposed (STD), BM = Motor Bottom Side, BL=Motor Left Side, BR = Motor Right Side

CP = Coupling include Dia 7 and 8 mm

Article number on Servo Motor

**Gantry Profiles and Cross Plates**

**XY GLT5 - 3-150/200-R - A1**

XY = X-Y Gantry Profile, YZ= Y-Z Cross Plates

Size of GLT module: 3,5,8,12

Size of connecting Linear Module

Stroke incl. Overlap on Connecting Linear module

Direction of Gantry Profile (Only in XY profile): R=Right, L= Left

Gantry Profile Combination Direction: A1, A2, A3, A4 (see picture below)

**X-Y Gantry Profile Combination Direction**

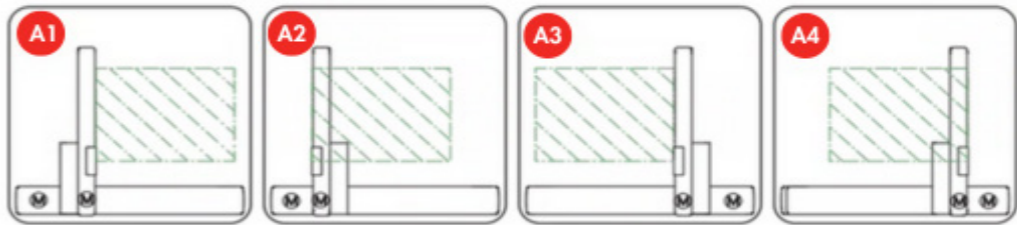

A1 and A3 standard. A2 and A4 available on request.

# Sample Solutions

## X-Y Gantry Solution

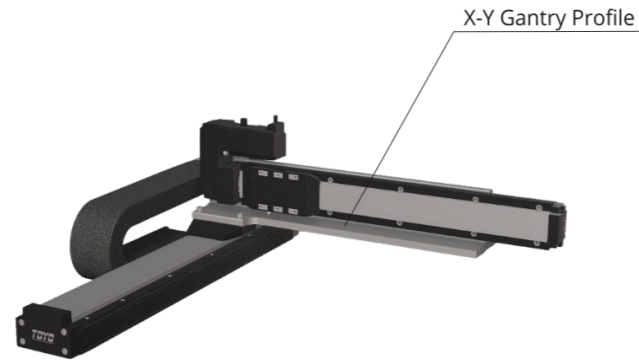

## X-Y-Z Gantry Solution

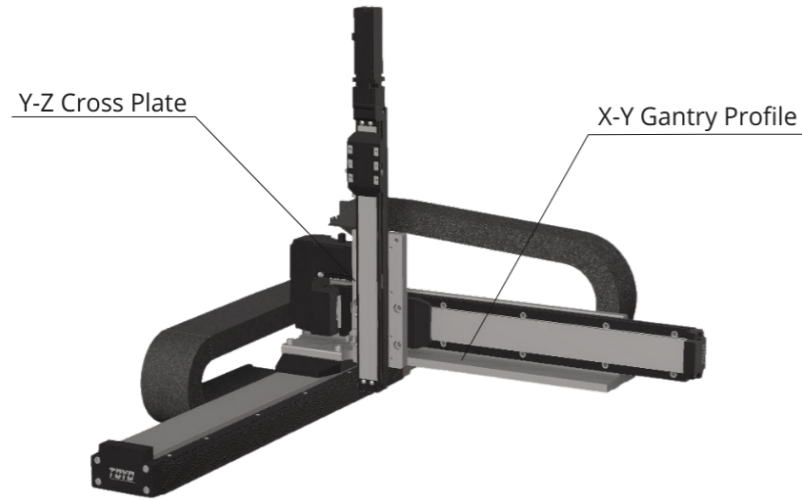

## X-Y-Z Gantry Solution, Parallell X-axes

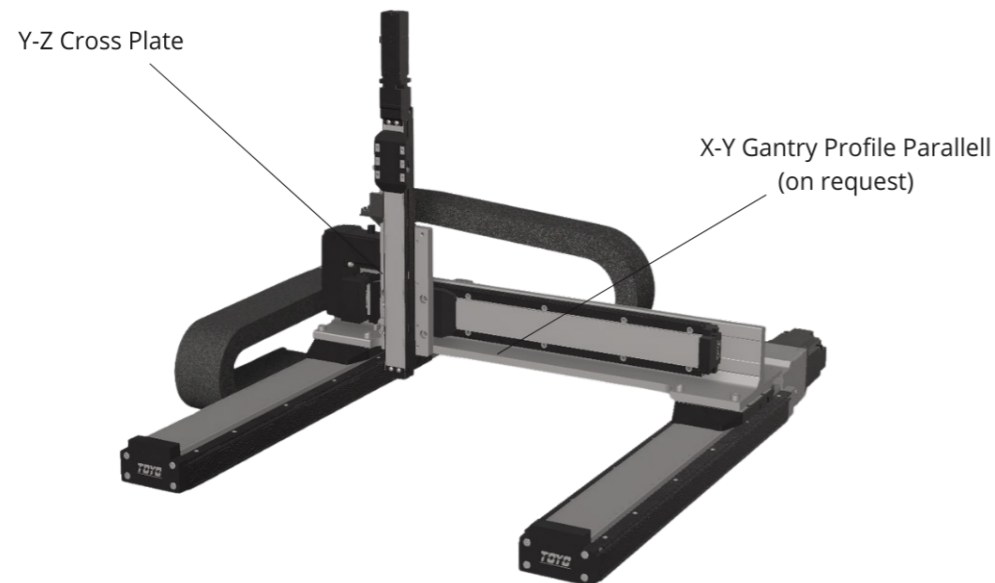

# Accessories Gantry Profile X-Y

## Gantry Profile XYGLT5-3

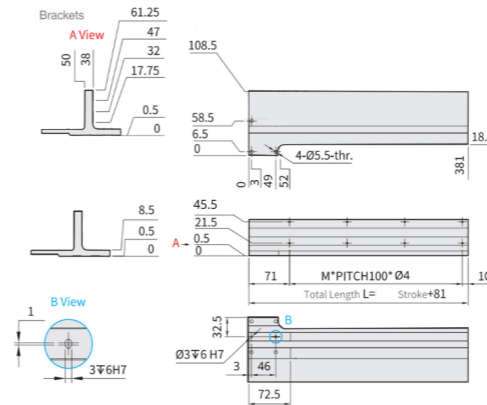

Stroke	100	150	200	250	300
L	181	281	381		
M	1	2	3		

Length Stroke in Y	Article Number Right	Article Number Left
50-100	XYGLT5-3-50/100RA1	XYGLT5-3-50/100LA3
150-200	XYGLT5-3-150/200RA1	XYGLT5-3-150/200LA3
250-300	XYGLT5-3-250/300RA1	XYGLT5-3-250/300LA3

A1 and A3 standard. A2 and A4 available on request.

## Gantry Profiles XYGLT12-8

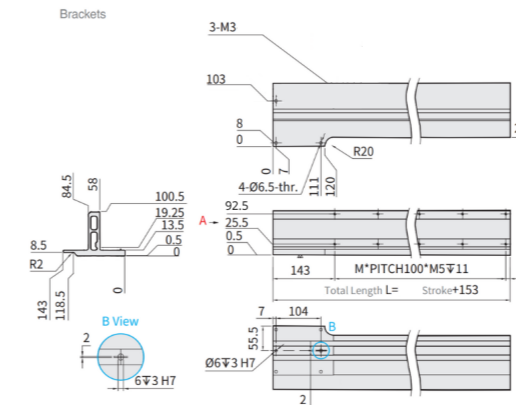

Stroke	100	150	200	250	300	350	400	450	500	550	600
L	253	353	453	553	653	753					
M	1	2	3	4	5	6					

Length Stroke in Y	Article Number Right	Article Number Left
50-100	XYGLT12-8-50/100RA1	XYGLT12-8-50/100LA3
150-200	XYGLT12-8-150/200RA1	XYGLT12-8-150/200LA3
250-300	XYGLT12-8-250/300RA1	XYGLT12-8-250/300LA3
350-400	XYGLT12-8-350/400RA1	XYGLT12-8-350/400LA3
450-500	XYGLT12-8-450/500RA1	XYGLT12-8-450/500LA3
550-600	XYGLT12-8-550/600RA1	XYGLT12-8-550/600LA3

A1 and A3 standard. A2 and A4 available on request.

## Gantry Profiles XYGLT8-5

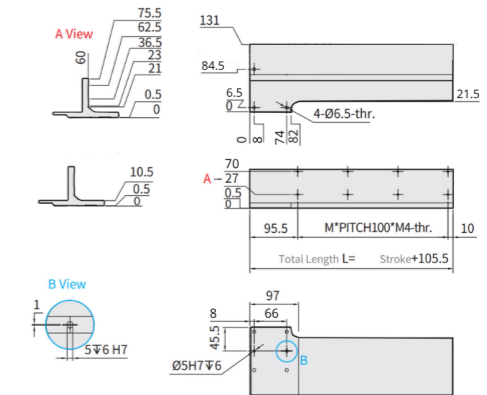

Stroke	100	150	200	250	300	350	400	450	500
L	205.5	305.5	405.5	505.5	605.5				
M	1	2	3	4	5				

Length Stroke in Y	Article Number Right	Article Number Left
50-100	XYGLT8-5-50/100RA1	XYGLT8-5-50/100LA3
150-200	XYGLT8-5-150/200RA1	XYGLT8-5-150/200LA3
250-300	XYGLT8-5-250/300RA1	XYGLT8-5-250/300LA3
350-400	XYGLT8-5-350/400RA1	XYGLT8-5-350/400LA3
450-500	XYGLT8-5-450/500RA1	XYGLT8-5-450/500LA3

A1 and A3 standard. A2 and A4 available on request.

## Gantry Profiles XYGLT12-12

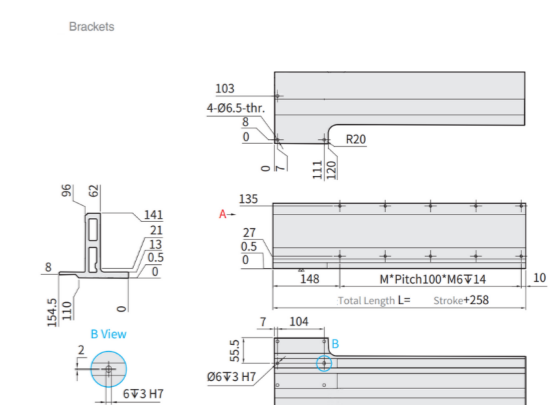

Stroke	100	150	200	250	300	350	400	450	500	550	600
L	358	458	558	658	758	858					
M	2	3	4	5	6	7					

Length Stroke in Y	Article Number Right	Article Number Left
50-100	XYGLT12-12-50/100RA1	XYGLT12-12-50/100LA3
150-200	XYGLT12-12-150/200RA1	XYGLT12-12-150/200LA3
250-300	XYGLT12-12-250/300RA1	XYGLT12-12-250/300LA3
350-400	XYGLT12-12-350/400RA1	XYGLT12-12-350/400LA3
450-500	XYGLT12-12-450/500RA1	XYGLT12-12-450/500LA3
550-600	XYGLT12-12-550/600RA1	XYGLT12-12-550/600LA3

A1 and A3 standard. A2 and A4 available on request.

## Accessories Cross Plates Y-Z

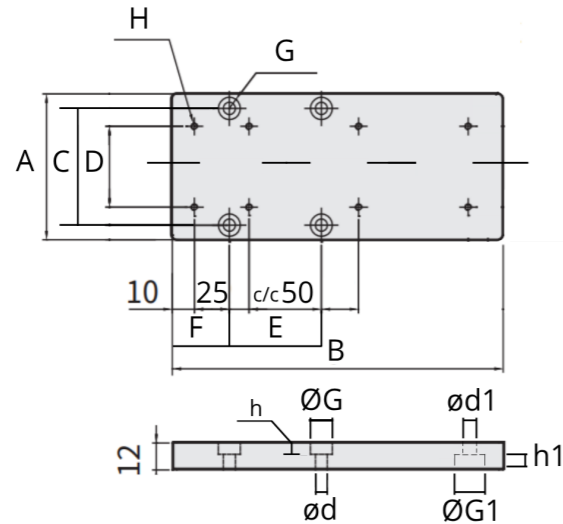

Unit mm

	A	B	C	D	E	F	G x h x d	H	G1 x h1 x d1
YZGLT 5-3	65	151	52	24	46	26	8 x 5 x 5	Ø6 x 4 x Ø4	6 x 4 x 4
YZGLT 5-5	65	151	52	43	46	26	8 x 5 x 5	m4	-
YZGLT 8-5	90	195	78	43	66	22.5	9 x 6 x 6	m4	-
YZGLT 8-8	90	195	78	67	66	22.5	9 x 6 x 6	m5	-
YZGLT 12-8	120	240	95	67	104	22.5	11 x 7 x 7	m5	-
YZGLT 12-12	120	240	95	108	104	22.5	11 x 7 x 7	m6	-

## Lubrication advice

Correct maintenance is important for maintaining the function of the linear module. The recommended lubrication for the linear module is grease, specifically AFEP2 or NSK LG-2 cleanroom ballscrew grease. Regular maintenance before operation helps ensure safety and extends the system's longevity.

Greasing can be done by both side of the linear carriage on the greasing nozzle. The greasing nozzle will equally distribute the grease to the linear carriage and the ball screw nut.

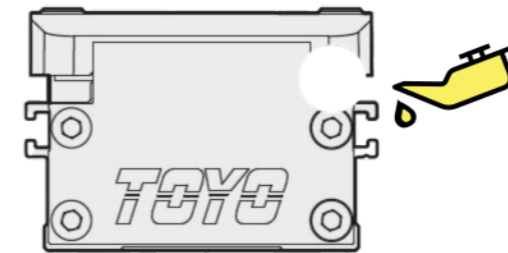

## Lifetime calculation

We offer lifetime calculations upon request. If you would like a lifetime calculation on your linear module, please provide the required details under "Desired operating conditions" shown in the image below, to help us generate an accurate calculation for you.

Desired operating conditions	Motor specs
Stroke : <input type="text" value="50"/> <input type="text" value="800"/> [mm]	Standard-50W
Payload : <input type="text" value="5"/> [kg]	Motor power : <input type="text" value="50"/> [W]
Duty Cycle : <input type="text" value="3"/> [s] Running time : <input type="text" value="8"/> hours/day	<input checked="" type="checkbox"/> Advanced
Number of round trips : <input type="text" value="10"/> [trip/minute]	Rated torque : <input type="text" value="0.16"/> [Nm]
Operating run days : <input type="text" value="200"/> day/year	Max. torque : <input type="text" value="0.56"/> [Nm]
<input checked="" type="checkbox"/> Expected life : <input type="text" value="15"/> year	Moment of inertia : <input type="text" value="0.000045"/> [kg·m <sup>2</sup> ]
<input checked="" type="checkbox"/> Running Speed : <input type="text" value="150"/> mm/s	Load inertia to moment ratio : <input type="text" value="15"/>
Acceleration : <input type="text" value="200"/> [mm/s <sup>2</sup> ]	

# Your Partner in Automation Solutions

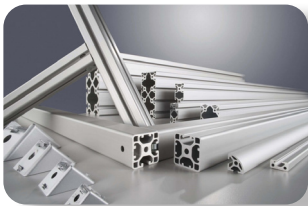

Item Aluminium Profiles



D30 Tube System



Work Bench System

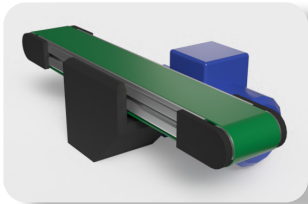

Conveyor Belt System

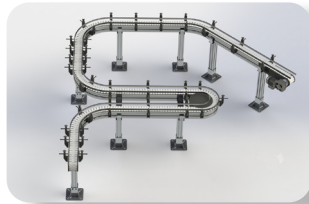

Chain Conveyors



Modular Belt Conveyors



Pallet Conveyors



Ball Bushings

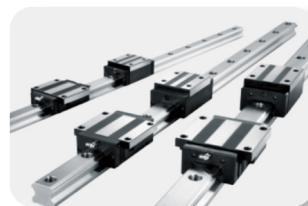

Linear Guides



Ball Screws

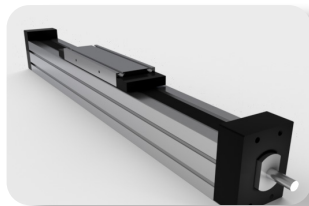

Linear Modules

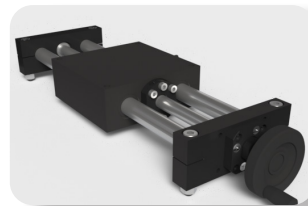

Adjustment Modules

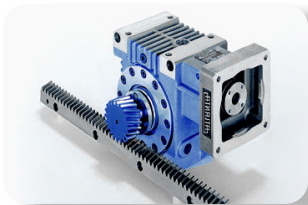

Rack and Pinion

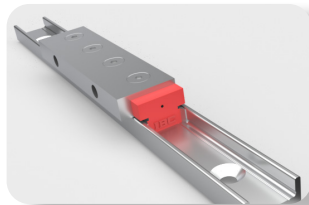

Compact Rail

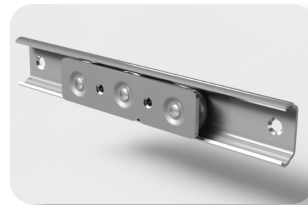

FlexFit



Complete Mechanical Solutions



Light Telescopic Rail

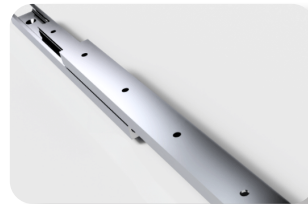

Heavy Telescopic Rail

**AluFlexGroup**  
YOUR PARTNER IN AUTOMATION SOLUTIONS

AluFlex AB | item profiili oy | LinearModul A/S | AluFlex System AS



**AluFlex AB**  
Kanongatan 84  
254 67 Helsingborg  
Tel +46 42 38 02 30  
orders@aluflex.se  
www.aluflex.se



**LinearModul A/S**  
Sivlandvaenget 13B  
5260 Odense S  
Tel +45 65 91 72 10  
orders@linearmodul.dk  
www.linearmodul.dk



**AluFlex System AS**  
Industrivegen 23B  
Postboks 2069 Jessheim  
Tel: +47 63 94 49 20  
orders@aluflex.no  
www.aluflex.no



**item profiili oy**  
Lyhtykuja 6  
00750 Helsinki, Finland  
Puh: +358 9 854 56 50  
orders@itemprofiili.fi  
www.itemprofiili.fi