

AluFlexGroup

YOUR PARTNER IN AUTOMATION SOLUTIONS

AluFlex AB | item profilli oy | LinearModul A/S | AluFlex System AS

LINEAR GUIDES



www.aluflex.com

Your Partner in Automation Solutions



Linear Guides



Item Aluminiumprofiles



D30 Tube System



Work Bench System

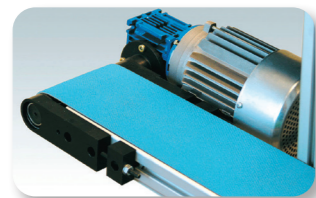

Belt Conveyor System

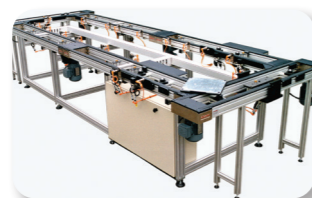

Palette Conveyor System



Lean Production System



Item News Every Year



Ball Bushings

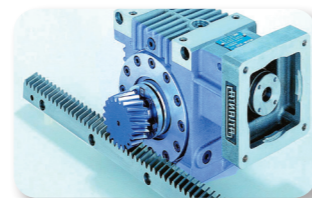

Rack and Pinion System



Compact Rail

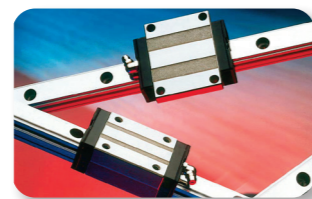

Linear Guides



Ball Screws



Easy Rail



Heavy Telescopic Rail



Light Telescopic Rail



Servo Motors

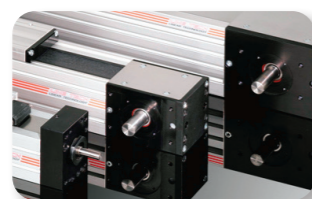

Linear Modules

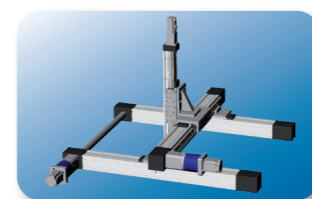

Complete Solutions

Index

Products

	page
Standard rail with MSA-E/LE flange type carriage	4
Standard rail with MSA-S/LS narrow type carriage	6
Stainless steel rail and carriage MSA-EM	8
MSA-T - Bottom threaded rail for MSA carriage	10
MSA-RHC - Hard chromed linear rail for MSA carriage	11
MSB-E/TE - Low standard/short flange type	12
MSB-S/TS - Low standard/short narrow type	14
Wide rail with MSG-E flange type carriage	16
Roller guide rail MSR-E/LE flange type carriage	18
MSC-M - Miniature standard type	20
Article numbers for the products	22

Accessories

Seals and metalscrapers	24
CC - Cover Strip	25
Grease nipples	25
Lubrication position	26
SL-Lubrication units	27

Product facts

Lubrication advice	29
Accuracy on rail and carriage	30
Tolerance between two rails - parallel deviation	34
Tolerance between two rails - level difference	35
Caps for rail	36
Tightening torque for rails	36
Shoulder height	37
Installation of rails	39
Lifetime calculation	39
Friction on movement	41

Standard rail with MSA-E/LE flange type carriage

The MSA-E/LE is a carriage with flange. This carriage is available in two different lengths, normal (MSA-E) or long (MSA-LE).

Fastening holes are accessible either from top (S1) or bottom (S2). The MSA-Series is specially suited for high precision and high rigidity required motion, for normal and high load.

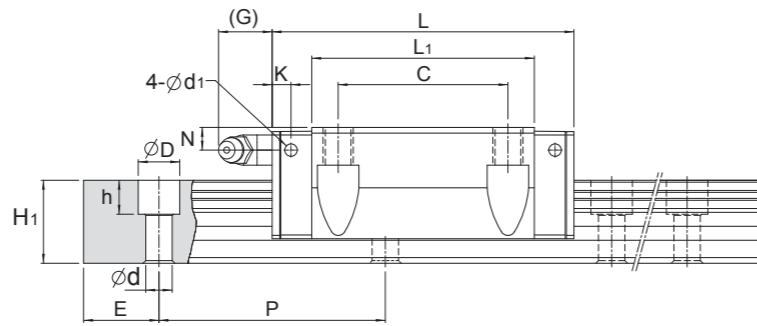
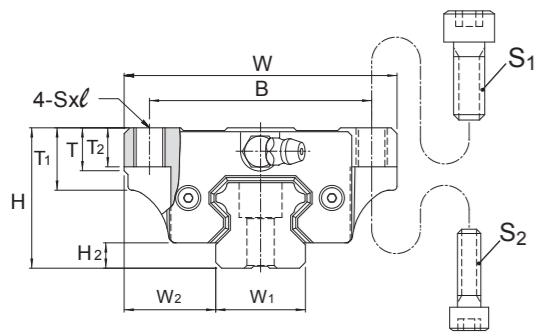
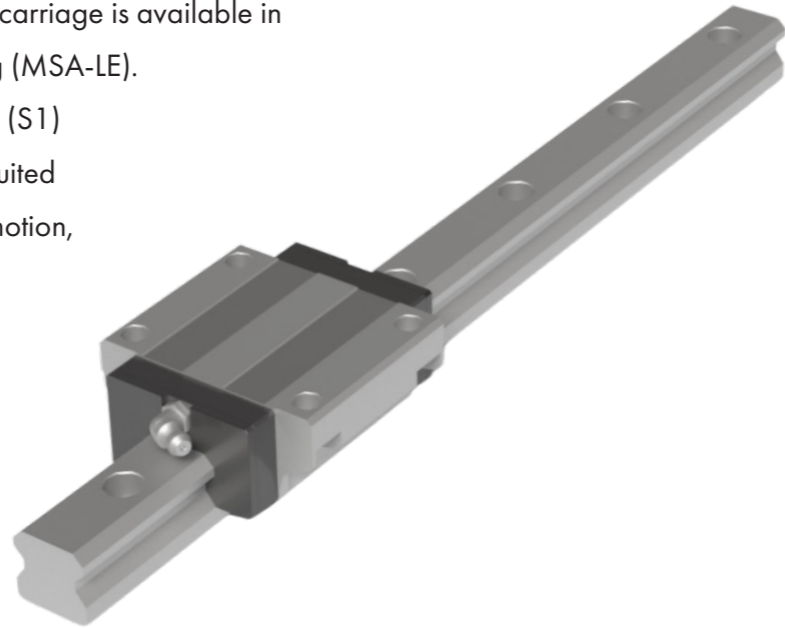

Compact Type, MSA Series

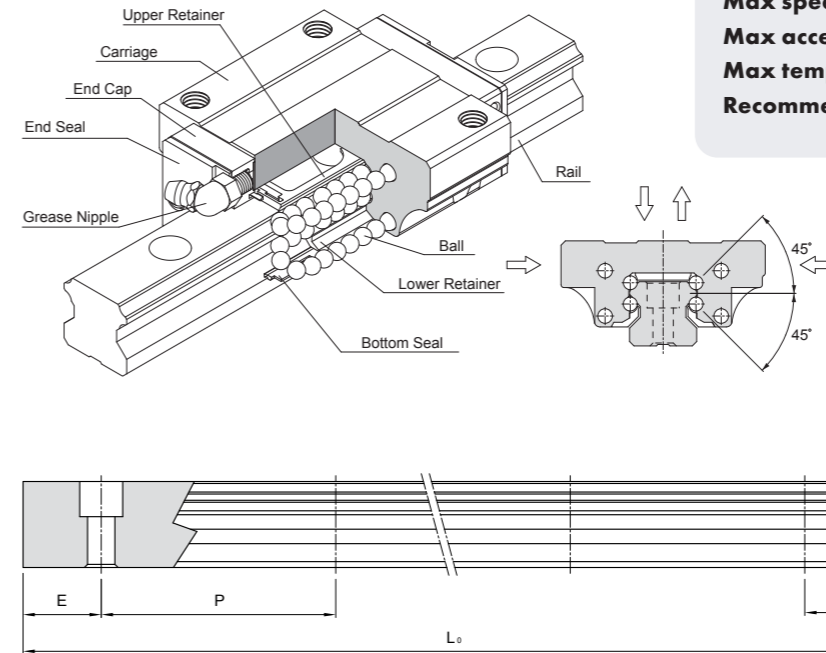

TECHNICAL PRODUCT SPECIFICATION

- Preload:** 2 % of dynamic load capacity
- Max speed:** 3 m/s
- Max acceleration:** 23 m/s²
- Max temp:** 80° Celsius
- Recommended load:** Max. 25 % of dynamic and moment rating

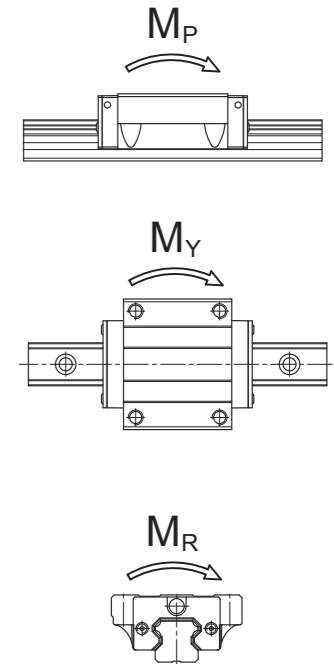

Model No.	MSA15R	MSA20R	MSA25R	MSA30R	MSA35R	MSA45R
Standard Pitch (P)	60	60	60	80	80	105
Standard (E_{std.})	20	20	20	20	20	22.5
Minimum (E_{min.})	5	6	7	8	8	11
Max (L_{0 max.})	4000	4 000	4 000	4 000	4 000	4 000
Fastening Bolt	M4	M5	M6	M8	M8	M12

Unit: mm

TECHNICAL DIMENSIONS

Model No.	External Dimension			Carriage Dimension																
	Height H	Width W	Length L	W ₂	H ₂	B	C	S x l	S ₁	S ₂	L1	T	T ₁	T ₂	N	G	K	d ₁	Grease Nipple	
MSA15E	24	47	56.3	16	4.2	38	30	M5x7	M5	M4	39.3	7	11	7	4.3	7	3.2	3.3	G-M4x0.75	
MSA20E	30	63	72.9	21.5	5	53	40	M6x10	M6	M5	51.3	7	10	10	5	12	5.8	3.3	G-M6x0.75	
MSA20LE			88.8						M6	M5	67.2									
MSA25E	36	70	81.6	23.5	6.5	57	45	M8x10	M8	M6	59	11	16	10	6	12	5.8	3.3	G-M6x0.75	
MSA25LE			100.6						M8	M6	78									
MSA30E	42	90	97	31	8	72	52	M10x10	M10	M8	71.4	11	18	10	7	12	6.5	3.3	G-M6x0.75	
MSA30LE			119.2						M10	M8	93.6									
MSA35E	48	100	111.2	33	9.5	82	62	M10x13	M10	M8	81	13	21	13	8			8.6	3.3	G-M6x0.75
MSA35LE			136.6						M10	M8	106.4									
MSA45E	60	120	137.7	37.5	10	100	80	M12x15	M12	M10	102.5	13	25	15	10			10.6	3.3	G-PT 1/8
MSA45LE			169.5						M12	M10	134.3									

SPECIFICATIONS

Model No.	Rail Dimension				Basic Load Rating		Static Moment Rating				Weight			
	Width W ₁	Height H ₁	Pitch P	E Std.	D x h x d	Dynamic C _N	Static C _O	M _P Nm	M _Y Nm	M _R Nm	Carriage kg	Rail		
MSA15E	15	15	60	20	7.5x5.3x4.5	11 800	18 900	120	680	120	680	140	0.18	1.5
MSA20E	20	18	60	20	9.5x8.5x6	19 200	29 500	230	1 420	230	1 420	290	0.4	2.4
MSA20LE						23 300	39 300	390	2 230	390	2 230	380	0.52	
MSA25E	23	22	60	20	11x9x7	28 100	42 400	390	2 200	390	2 200	480	0.62	3.4
MSA25LE						34 400	56 600	670	3 520	670	3 520	630	0.82	
MSA30E	28	26	80	20	14x12x9	39 200	57 800	620	3 670	620	3 670	790	1.09	4.8
MSA30LE						47 900	77 000	1 070	5 810	1 070	5 810	1 050	1.43	
MSA35E	34	29	80	20	14x12x9	52 000	75 500	930	5 470	930	5 470	1 250	1.61	6.6
MSA35LE						63 600	100 600	1 600	8 670	1 600	8 670	1 670	2.11	
MSA45E	45	38	105	22.5	20x17x14	83 800	117 900	1 810	10 670	1 810	10 670	2 570	2.98	11.5
MSA45LE						102 400	157 300	3 130	16 950	3 130	16 950	3 430	3.9	

Note*: Single carriage only. Double: Double carriage closely contacting with each other.

Standard rail with MSA-S/LS narrow type carriage

The MSA S/LS is a narrow square type carriage. This carriage is available in two different lengths, normal (MSA-S) or long (MSA-LS). Fastening holes are only accessible from the top. The MSA-Series is specially suited for high precision and high rigidity required motion, for normal and high load.

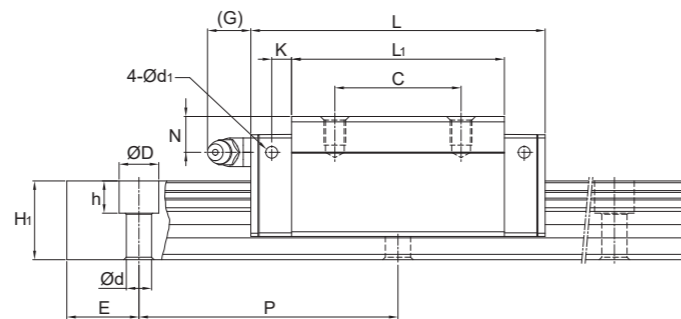
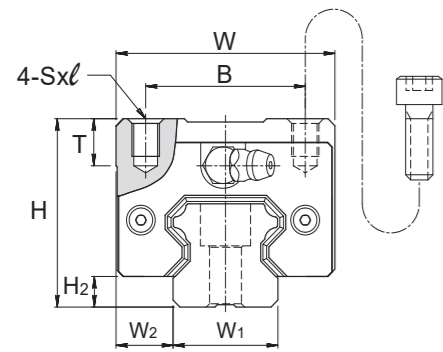
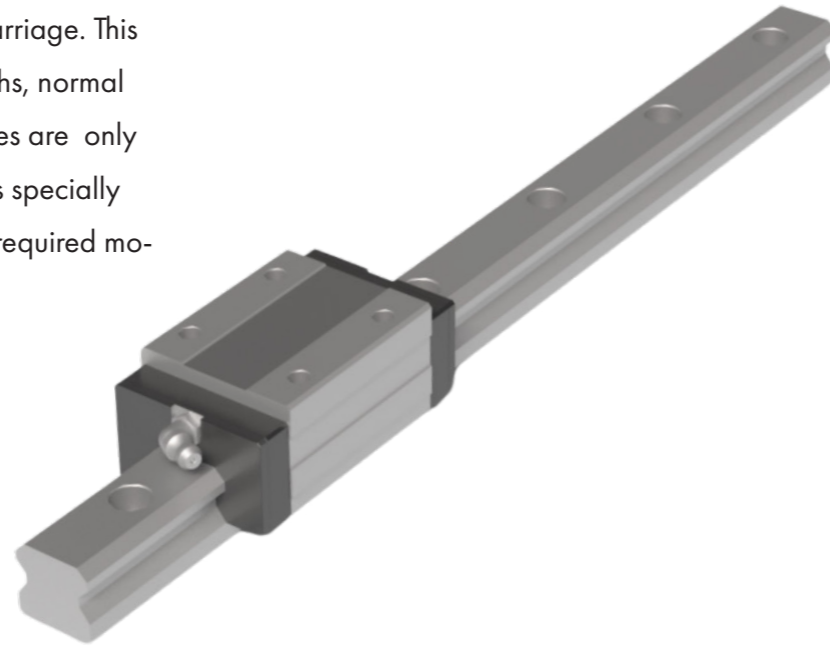

TECHNICAL DIMENSIONS

Model No.	External Dimension					Carriage Dimension										
	Height H	Width W	Length L	W ₂	H ₂	B	C	S x l	L ₁	T	N	G	K	d ₁	Grease Nipple	
MSA15S	28	34	56.3	9.5	4.2	26	26	M4x5	39.3	7.2	8.3	7	3.2	3.3	G-M4x0.75	
MSA20S	30	44	72.9	12	5	32	36	M5x6	51.3	8	5	12	5.8	3.3	G-M6x0.75	
MSA20LS			88.8						67.2							
MSA25S-ALZ	36	48	81.6	12.5	6.5	35	35	M6x8	59	10	10	12	5.8	3.3	G-M6x0.75	
MSA25S	40	48	81.6	12.5	6.5	35	35	M6x8	59	10	10	12	5.8	3.3	G-M6x0.75	
MSA25LS			100.6						78							
MSA30S	45	60	97	16	8	40	40	M8x10	71.4	11.7	10	12	6.5	3.3	G-M6x0.75	
MSA30LS			119.2						93.6							
MSA35S	55	70	111.2	18	9.5	50	50	M8x12	81	12.7	15	11.5	8.6	3.3	G-M6x0.75	
MSA35LS			136.6						106.4							
MSA45S	70	86	137.7	20.5	10	60	60	M10x17	102.5	16	20	13.5	10.6	3.3	G-PT 1/8	
MSA45LS			169.5						134.3							

Compact Type, MSA Series

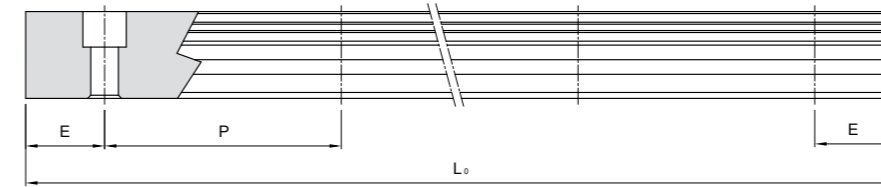
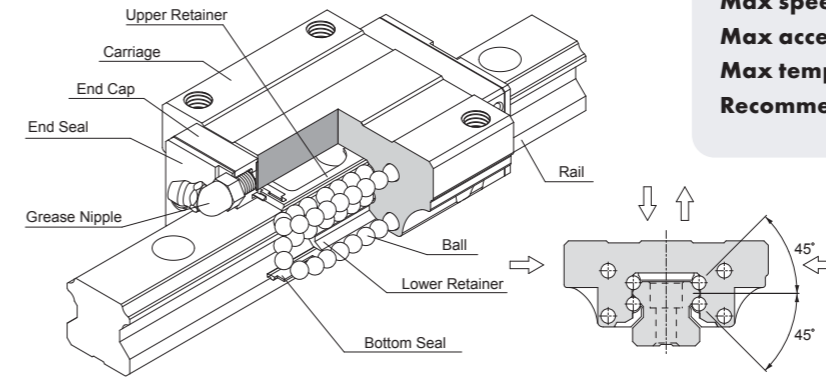

TECHNICAL PRODUCT SPECIFICATION

- Preload:** 2 % of dynamic load capacity
- Max speed:** 3 m/s
- Max acceleration:** 23 m/s²
- Max temp:** 80° Celsius
- Recommended load:** Max. 25 % of dynamic and moment rating

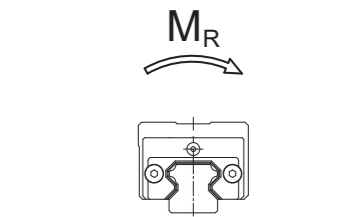
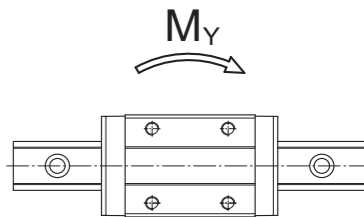
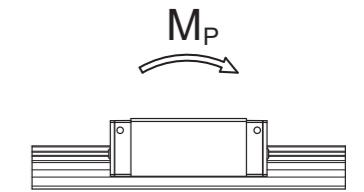

Unit: mm

Model No.	MSA15R	MSA20R	MSA25R	MSA30R	MSA35R	MSA45R
Standard Pitch (P)	60	60	60	80	80	105
Standard (E_{std.})	20	20	20	20	20	22.5
Minimum (E_{min.})	5	6	7	8	8	11
Max (L_o max.)	4000	4 000	4 000	4 000	4 000	4 000
Fastening Bolt	M4	M5	M6	M8	M8	M12

SPECIFICATIONS

Model No.	Rail Dimension					Basic Load Rating		Static Moment Rating				Weight		
	Width W ₁	Height H ₁	Pitch P	E Std.	D x h x d	Dynamic C _N	Static C _O	M _p Nm		M _y Nm		M _r Nm	Carriage kg	Rail kg/m
								Single*	Double*	Single*	Double*			
MSA15S	15	15	60	20	7.5x5.3x4.5	11 800	18 900	120	680	120	680	140	0.18	1.5
MSA20S	20	18	60	20	9.5x8.5x6	19 200	29 500	230	1 420	230	1 420	290	0.3	2.4
MSA20LS								390	2 230	390	2 230	380	0.39	
MSA25S-ALZ	23	22	60	20	11x9x7	28 100	42 400	390	2 200	390	2 200	480	0.52	3.4
MSA25S	23	22	60	20	11x9x7	28 100	42 400	390	2 200	390	2 200	480	0.52	3.4
MSA25LS								670	3 520	670	3 520	630	0.68	
MSA30S	28	26	80	20	14x12x9	39 200	57 800	620	3 670	620	3 670	790	0.86	4.8
MSA30LS								1 070	5 810	1 070	5 810	1 050	1.12	
MSA35S	34	29	80	20	14x12x9	52 000	75 500	930	5 470	930	5 470	1 250	1.45	6.6
MSA35LS								1 600	8 670	1 600	8 670	1 670	1.9	
MSA45S	45	38	105	22.5	20x17x14	83 800	117 900	1 810	10 670	1 810	10 670	2 570	2.83	11.5
MSA45LS								3 130	16 950	3 130	16 950	3 430	3.7	

Note*: Single Carriage only. Double: Double Carriage closely contacting with each other.

Stainless steel rail and carriage MSA-EM

The MSA-E is a carriage with flange. This carriage is available in two different lengths, normal (MSA-E) or long (MSA-LE).

Fastening holes are accessible either from top (S1) or bottom (S2). The MSA-Series is specially suited for high precision and high rigidity required motion, for normal and high load.

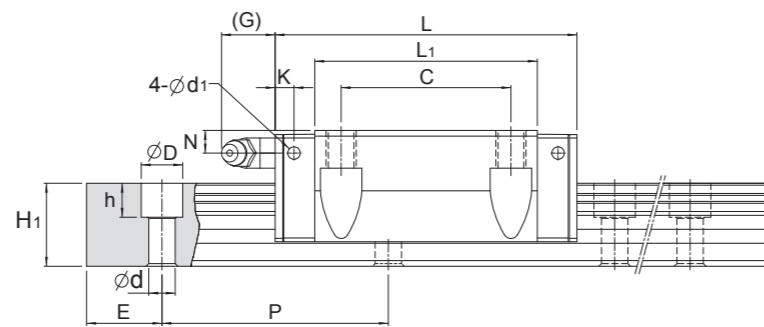
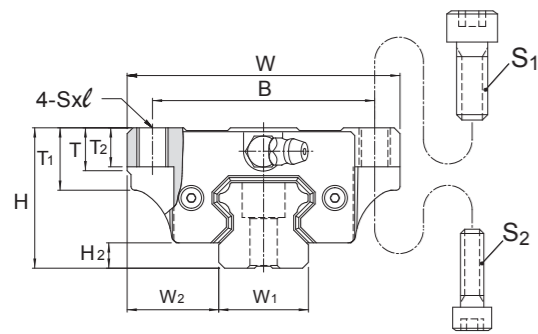
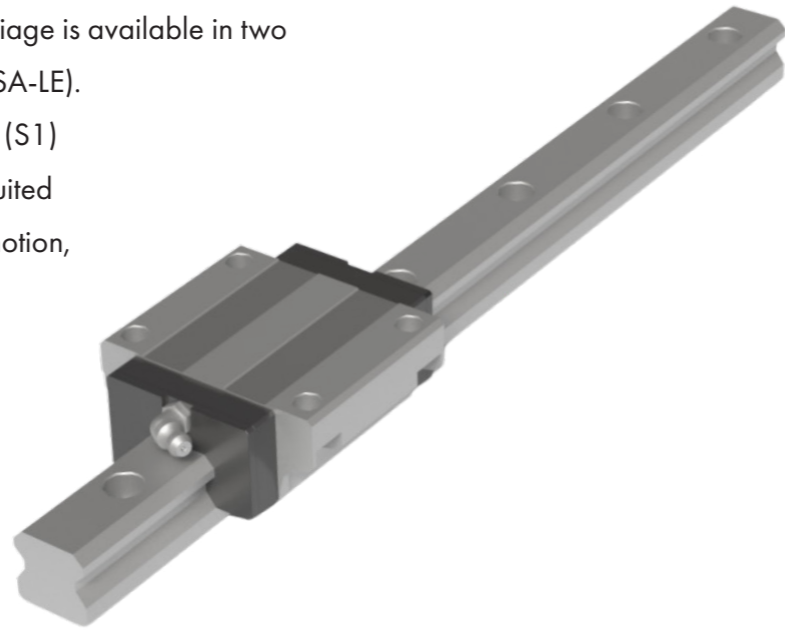

Compact Type, MSA Series

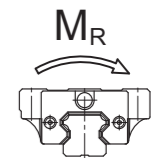
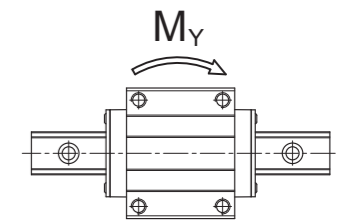
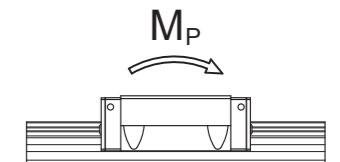
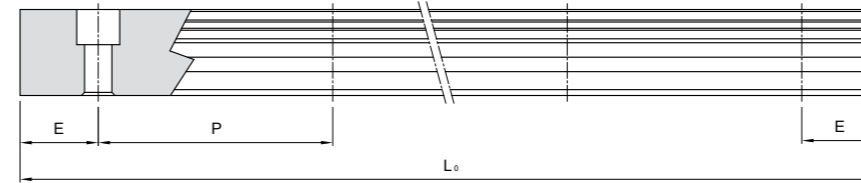
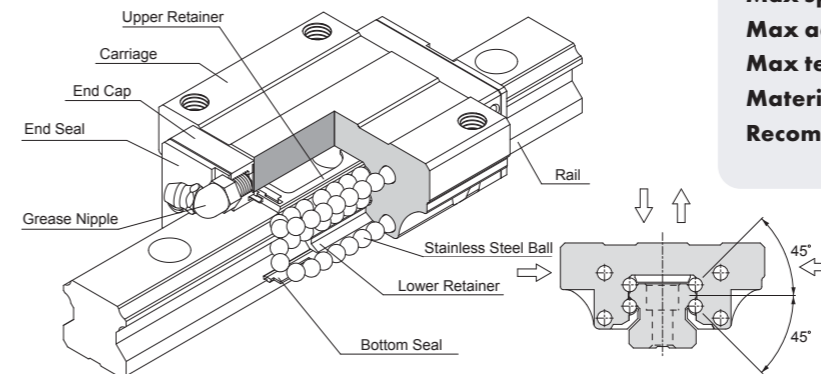

TECHNICAL PRODUCT SPECIFICATION

- Preload:** 2 % of dynamic load capacity
- Max speed:** 3 m/s
- Max acceleration:** 23 m/s²
- Max temp:** 80° Celsius
- Material:** SUS 440C
- Recommended load:** Max. 25 % of dynamic and moment rating

Model No.	Unit: mm		
	MSA15RM	MSA20RM	MSA25RM
Standard Pitch (P)	60	60	60
Standard (E_{std.})	20	20	20
Minimum (E_{min.})	5	6	7
Max (L₀ max.)	4 000	4 000	4 000
Fastening Bolt	M4	M5	M6

TECHNICAL DIMENSIONS

Model No.	External Dimension					Carriage Dimension											
	Height H	Width W	Length L	W ₂	H ₂	B	C	S x l	L1	T	T ₁	T ₂	N	G	K	d ₁	Grease Nipple
MSA15EM	24	47	56.3	16	4.2	38	30	M5x7	39.3	7	11	7	4.3	7	3.2	3.3	G-M4x0.75
MSA20EM	30	63	72.9	21.5	5	53	40	M6x10	51.3	7	10	10	5	12	5.8	3.3	G-M6x0.75
MSA25EM	36	70	81.6	23.5	6.5	57	45	M8x10	59	11	16	10	6	12	5.8	3.3	G-M6x0.75

SPECIFICATIONS

Model No.	Rail Dimension				Basic Load Rating		Static Moment Rating				Weight			
	Width W ₁	Height H ₁	Pitch P	E Std.	D x h x d	Dynamic C _N	Static C _O	M _p N-m		M _y N-m		Carriage kg	Rail kg/m	
								Single*	Double*	Single*	Double*			
MSA15EM	15	15	60	20	7.5x5.3x4.5	11 800	18 900	120	680	120	680	140	0.18	1.5
MSA20EM	20	18	60	20	9.5x8.5x6	19 200	29 500	230	1420	230	1420	290	0.4	2.4
MSA25EM	23	22	60	20	11x9x7	28 100	42 400	390	2200	390	2200	480	0.62	3.4

Note*: Single carriage only. Double: Double carriage closely contacting with each other.

MSA-T - Bottom threaded rail for MSA carriage

The MSA-T bottom threaded rail for MSA carriage is designed to provide a clean top surface on the rail, making it well suited for dirtier operating environments. It is also recommended in applications where cleanliness is required or when mounting from below is preferred. All MSA carriages are compatible with the MSA-T rail.

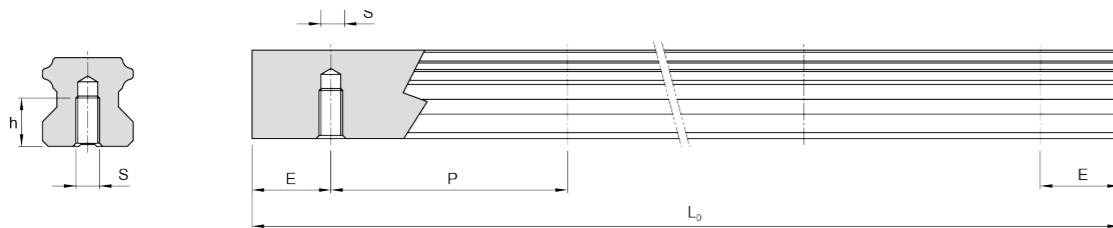

TECHNICAL DIMENSIONS

Unit: mm

Model No.	MSA15T	MSA20T	MSA25T	MSA30T
Standard Pitch (P)	60	60	60	80
Standard (E _{std.})	20	20	20	20
Minimum (E _{min.})	5	6	7	8
Max (L ₀ max.)	4 000	4 000	4 000	4 000

Rail Model	MSA15T	MSA20T	MSA25T	MSA30T
S	M5	M6	M6	M8
h (mm)	8	10	12	15

MSA-RHC - Hard chromed linear rail for MSA carriage

The MSA-RHC hard chromed linear rail for MSA carriage is designed for demanding environments such as welding operations, where weld spatter is less likely to adhere to the hardened chrome surface. The hard-chromed rail is also suitable for use in corrosive environments where enhanced resistance to corrosion is required. All MSA carriages are compatible with the MSA-15RHC rail.

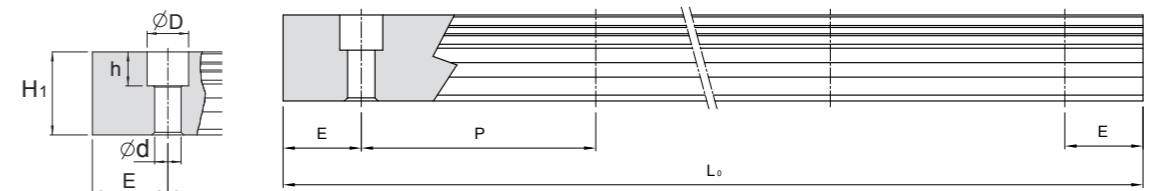
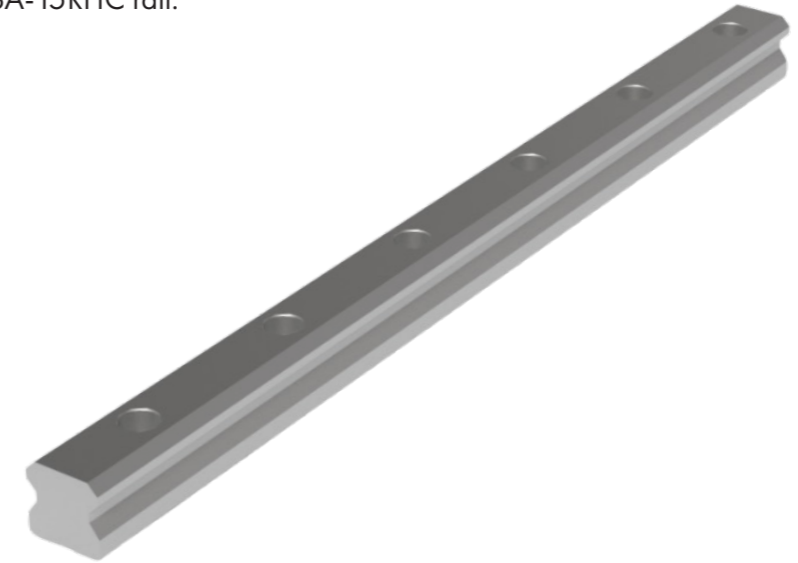

TECHNICAL DIMENSIONS

Unit: mm

Model No.	MSA15RHC	MSA20RHC	MSA25RHC	MSA30RHC	MSA35RHC
Standard Pitch (P)	60	60	60	80	80
Standard (E _{std.})	20	20	20	20	20
Minimum (E _{min.})	5	6	7	8	8
Max (L ₀ max.)	4 000	4 000	4 000	4 000	4 000
Fastening Bolt	M4	M5	M6	M8	M8

Rail Model	MSA15RHC	MSA20RHC	MSA25RHC	MSA30RHC	MSA35RHC
D	7.5	9.5	11	14	14
d	4.5	6	7	9	9
h	5.3	8.5	9	12	12
h1	15	18	22	26	29

MSB-E/TE - Low standard/short flange type

The MSB-E/TE is a low carriage with flange. This carriage is available in two different lengths, short (MSB-TE) or normal (MSB-E). Fastening holes are accessible either from top (S1) or bottom (S2). Short carriages are mostly used in pairs. The MSB-Series is used for the most compact solution for light and normal loads.

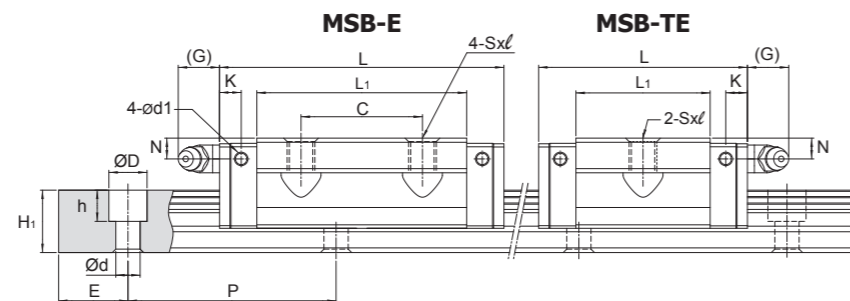
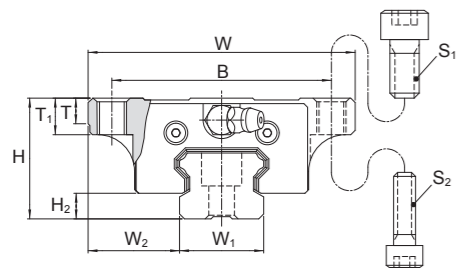
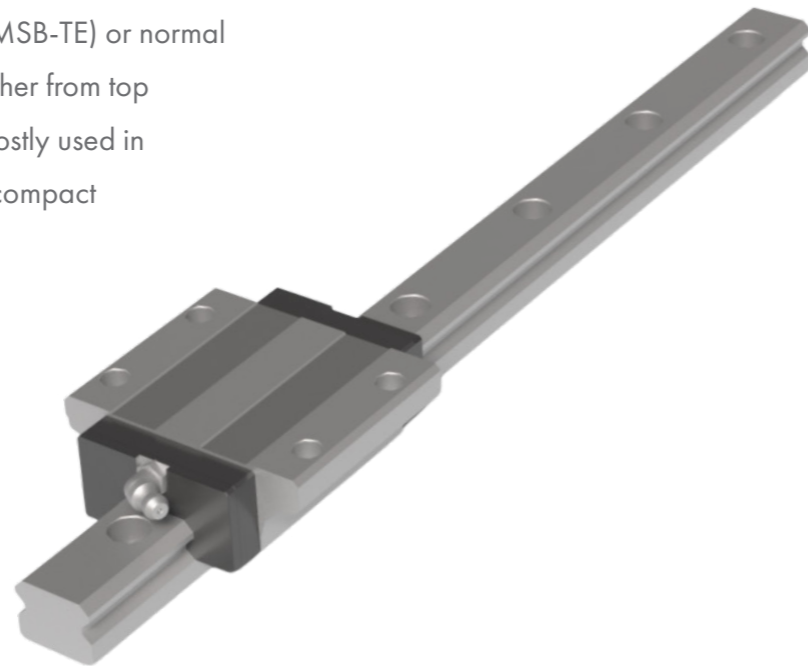

Compact Type, MSB Series

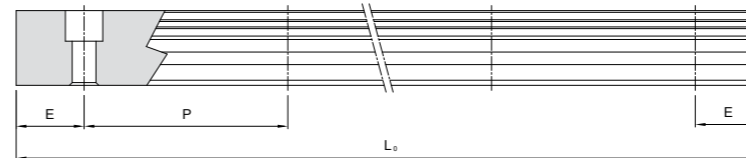
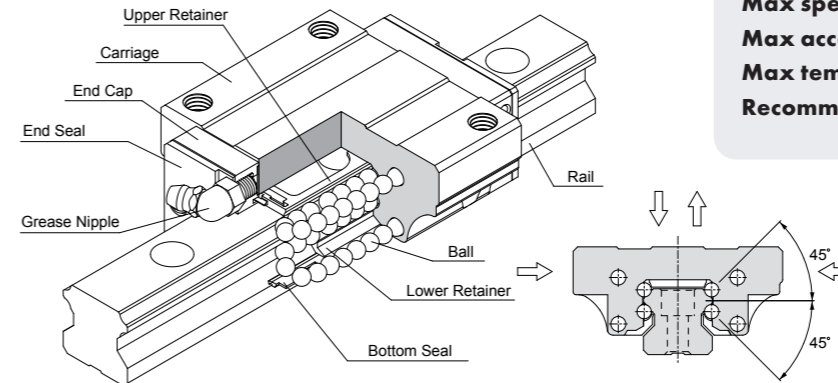

TECHNICAL PRODUCT SPECIFICATION

- Preload:** 2 % of dynamic load capacity
- Max speed:** 3 m/s
- Max acceleration:** 23 m/s²
- Max temp:** 80° Celsius
- Recommended load:** Max. 25 % of dynamic and moment rating

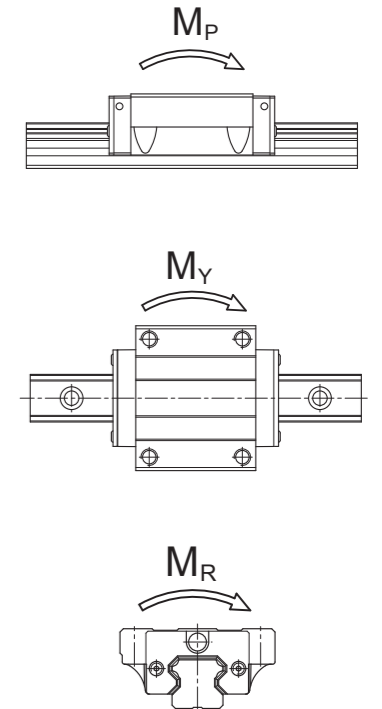

Unit: mm

Model No.	MSB15U	MSB20R	MSB25R	MSB30R	MSB35R
Standard Pitch (P)	60	60	60	80	80
Standard (E_{std.})	20	20	20	20	20
Minimum (E_{min.})	5	6	7	7	8
Max (L₀ max.)	2 000	4 000	4 000	4 000	4 000
Fastening Bolt	M4	M5	M6	M6	M8

TECHNICAL DIMENSIONS

Model No.	External Dimension			Carriage Dimension														
	Height H	Width W	Length L	W ₂	H ₂	B	C	S x l	S ₁	S ₂	L ₁	T	T ₁	N	G	K	d1	Grease Nipple
MSB15TE	24	52	40	18.5	4.5	41	-	M5x7	M5	M4	23.5	5	7	5.5	5.5	5.1	3.3	G-M4x0.75
MSB15E			57				26		M5	M4	40.5							
MSB20TE	28	59	48	19.5	6	49	-	M6x9	M6	M5	29	5	9	5.5	12	5.9	3.3	G-M6x0.75
MSB20E			67				32		M6	M5	48							
MSB25TE	33	73	60.2	25	7	60	-	M8x10	M8	M6	38.7	7	10	6	12	6.3	3.3	G-M6x0.75
MSB25E			82				35		M8	M6	60.5							
MSB30TE	42	90	68	31	9.5	72	-	M10x10	M10	M8	43.3	7	10	8	12	6.3	3.3	G-M6x0.75
MSB30E			96.7				40		M10	M8	72							
MSB35TE	48	100	78	33	9.5	82	-	M10x13	M10	M8	46	9	13	8.5	12	9.8	3.3	G-M6x0.75
MSB35E			112				50		M10	M8	80							

SPECIFICATIONS

Model No.	Rail Dimension				Basic Load Rating	Static Moment Rating				Weight			
	Width W ₁	Height H ₁	Pitch P	E Std.		D x h x d	Dynamic C _N	Static C _O	M _p Nm	M _y Nm	M _r Nm	Carriage kg	Rail kg/m
MSB15TE	15	12.5	60	20	7.5x5.3x4.5	6 700	9 600	40	260	40	260	70	0.12
MSB15E								100	610	100	610	130	
MSB20TE	20	15	60	20	9.5x8.5x6	9 700	14 200	70	440	70	440	140	0.20
MSB20E								180	970	180	970	240	
MSB25TE	23	18	60	20	11x9x7	15 600	22 100	130	910	130	910	260	0.39
MSB25E								350	1 870	350	1 870	430	
MSB30TE	28	23	80	20	11x9x7	23 100	31 800	230	1 390	230	1 390	450	0.65
MSB30E								600	3 150	600	3 150	740	
MSB35TE	34	27.5	80	20	14x12x9	35 700	44 000	340	2 810	340	2 810	750	0.91
MSB35E								930	5 470	930	5 470	1 280	

Note*: Single Carriage only. Double: Double Carriage closely contacting with each other.

MSB-S/TS - Low standard/short narrow type

The MSB-S/TS is a low narrow square type carriage. This carriage is available in two different lengths, short (MSB-TS) or normal (MSB-S). Fastening holes are only accessible from the top. Short carriages are mostly used in pairs. The MSB-Series is used for the most compact solution for light and normal loads.

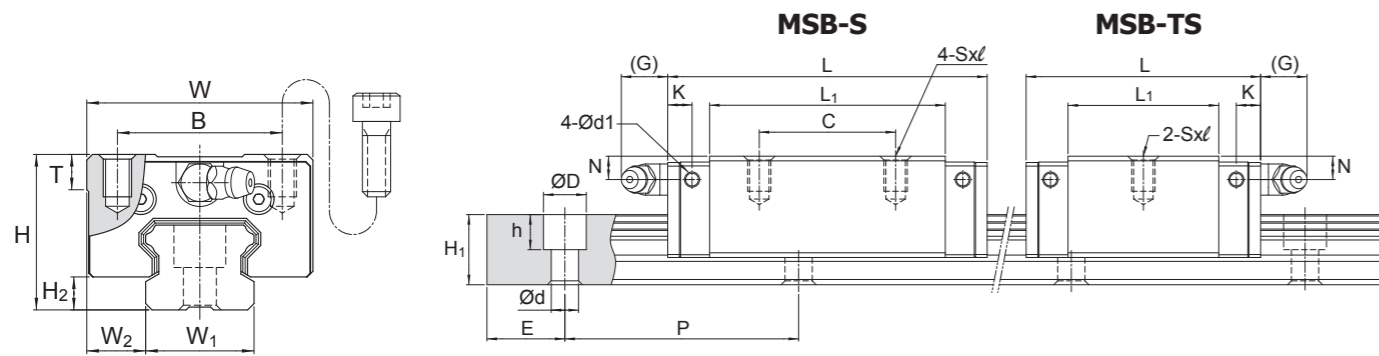
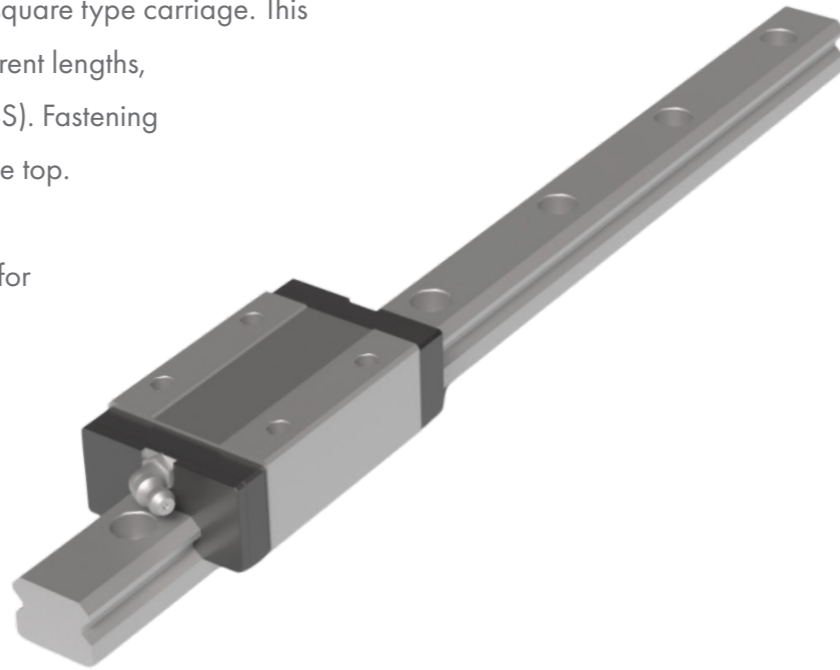

Compact Type, MSB Series

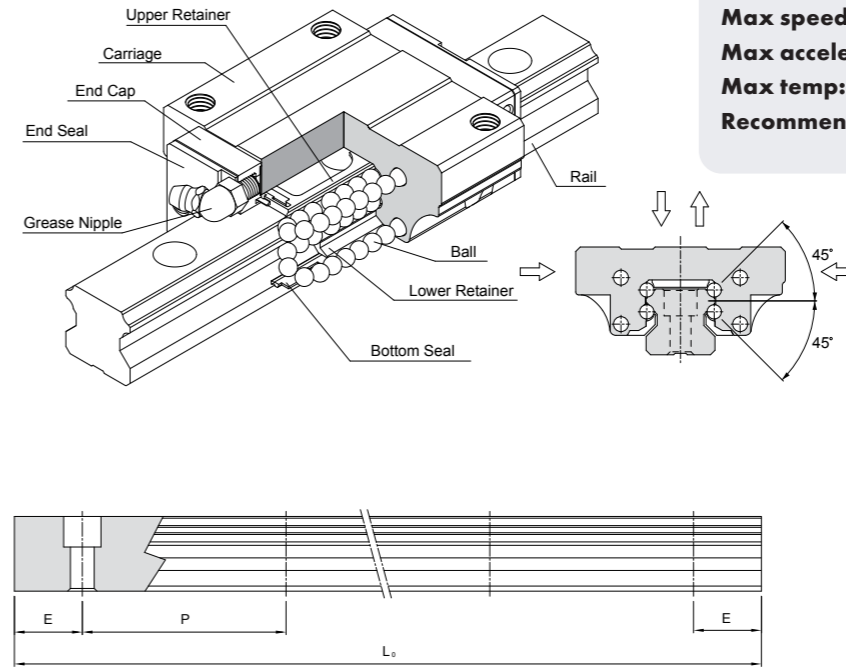

TECHNICAL PRODUCT SPECIFICATION

- Preload:** 2 % of dynamic load capacity
- Max speed:** 3 m/s
- Max acceleration:** 23 m/s²
- Max temp:** 80° Celsius
- Recommended load:** Max. 25 % of dynamic and moment rating

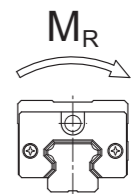
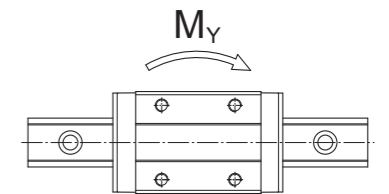
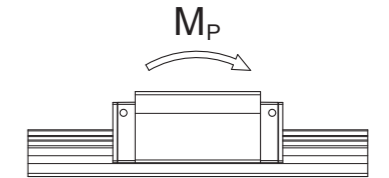

Unit: mm

Model No.	MSB15U	MSB20R	MSB25R	MSB30R	MSB35R
Standard Pitch (P)	60	60	60	80	80
Standard (E_{std.})	20	20	20	20	20
Minimum (E_{min.})	5	6	7	7	8
Max (L₀ max.)	2 000	4 000	4 000	4 000	4 000
Fastening Bolt	M4	M5	M6	M6	M8

TECHNICAL DIMENSIONS

Model No.	External dimension					Carriage dimension									
	Height H	Width W	Length L	W ₂	H ₂	B	C	S x I	L ₁	T	N	G	K	d ₁	Grease Nipple
MSB15TS	24	34	40	9.5	4.5	26	-	M4x6	23.5	6	5.5	5.5	5.1	3.3	G-M4x0.75
MSB15S			57				40.5								
MSB20TS	28	42	48	11	6	32	-	M5x7	29	6	5.5	12	5.9	3.3	G-M6x0.75
MSB20S			67				48								
MSB25TS	33	48	60.2	12.5	7	35	-	M6x9	38.7	8	6	12	6.3	3.3	G-M6x0.75
MSB25S			82				60.5								
MSB30TS	42	60	68	16	9.5	40	-	M8x12	43.3	8	8	12	6.3	3.3	G-M6x0.75
MSB30S			96.7				72								
MSB35TS	48	70	78	18	9.5	50	-	M8x12	46	12.5	8.5	11.5	9.8	3.3	G-M6x0.75
MSB35S			112				80								

SPECIFICATIONS

Model No.	Rail Dimension				Basic Load Rating		Static Moment Rating				Weight		
	Width W ₁	Height H ₁	Pitch P	E Std.	D x h x d	Dynamic C _N	Static C _O	M _P Nm	M _Y Nm	M _R Nm	Carriage kg	Rail kg/m	
MSB15TS	15	12.5	60	20	7.5x5.3x4.5	6 700	9 600	40	260	40	260	70	1.2
MSB15S						10 000	16 900	100	610	100	610	130	
MSB20TS	20	15	60	20	9.5x8.5x6	9 700	14 200	70	440	70	440	140	2
MSB20S						13 900	23 600	180	970	180	970	240	
MSB25TS	23	18	60	20	11x9x7	15 600	22 100	130	910	130	910	260	3
MSB25S						22 300	36 900	350	1 870	350	1 870	430	
MSB30TS	28	23	80	20	11x9x7	23 100	31 800	230	1 390	230	1 390	450	4.4
MSB30S						32 900	53 100	600	3 150	600	3 150	740	
MSB35TS	34	27.5	80	20	14x12x9	35 700	44 000	340	2 810	340	2 810	750	6.2
MSB35S						52 000	75 500	930	5 470	930	5 470	1 280	

Note*: Single Carriage only. Double: Double Carriage closely contacting with each other.

Wide rail with MSG-E flange type carriage

The MSG-E is a flanged carriage. The mounting holes are accessible from either the top (S1) or the bottom (S2). The MSG is specially suited for high-precision, compact linear applications and is designed to handle high loads.

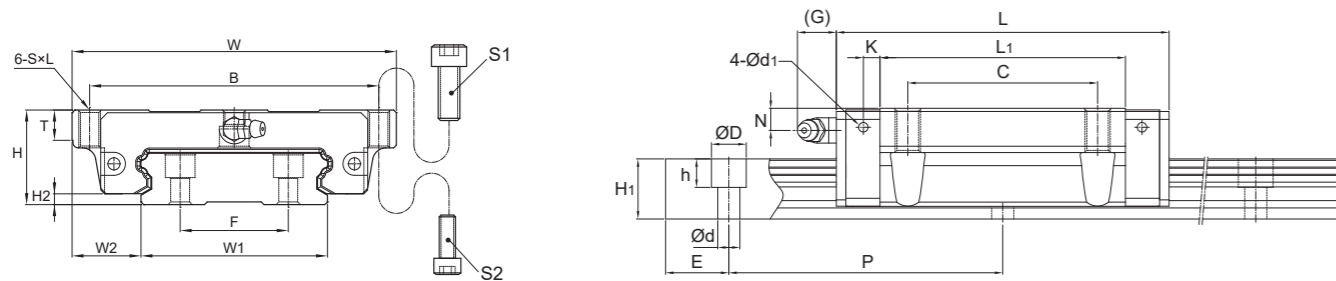
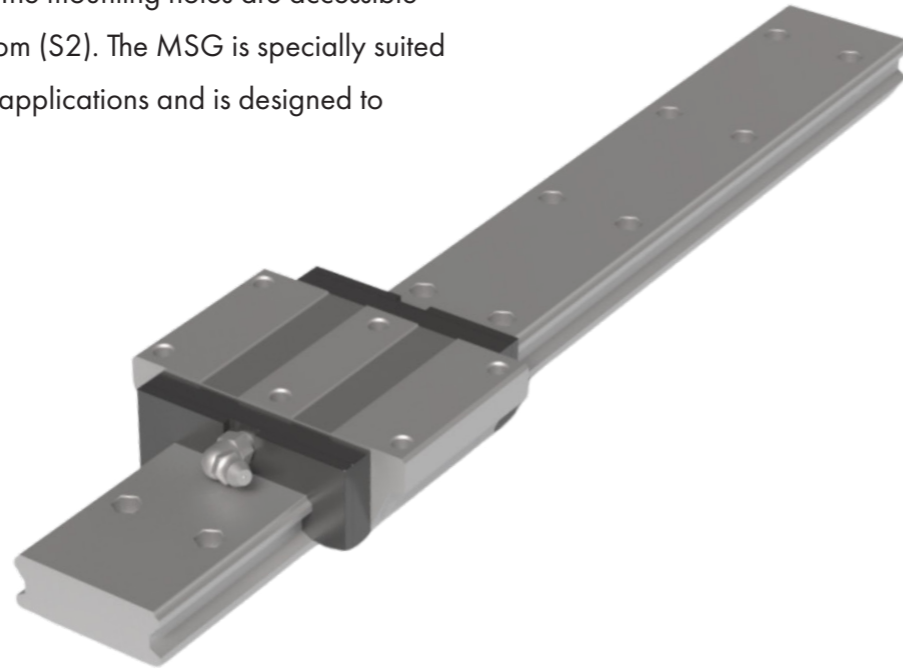

Compact Type, MSG Series

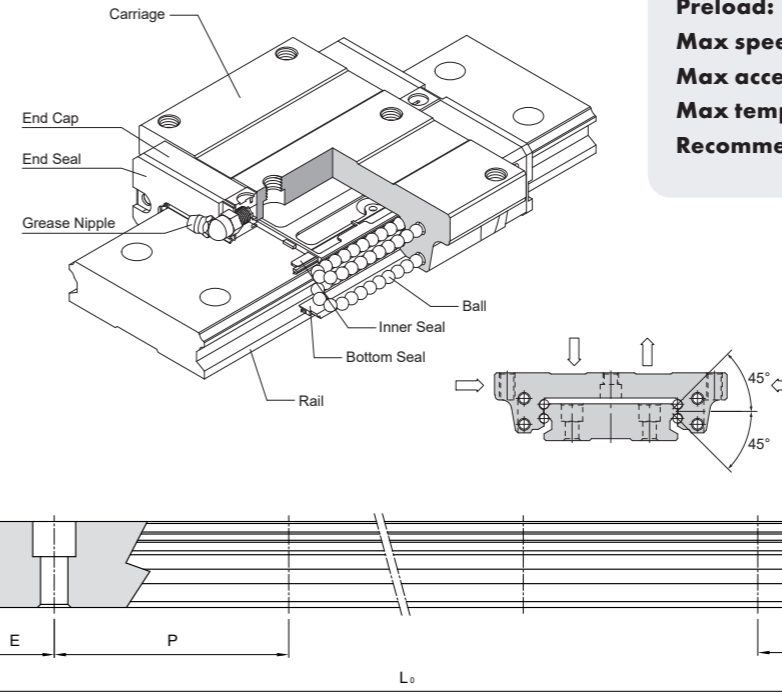

TECHNICAL PRODUCT SPECIFICATION

- Preload:** 2 % of dynamic load capacity
- Max speed:** 2 m/s
- Max acceleration:** 10 m/s²
- Max temp:** 80° Celsius
- Recommended load:** Max. 25 % of dynamic and moment rating

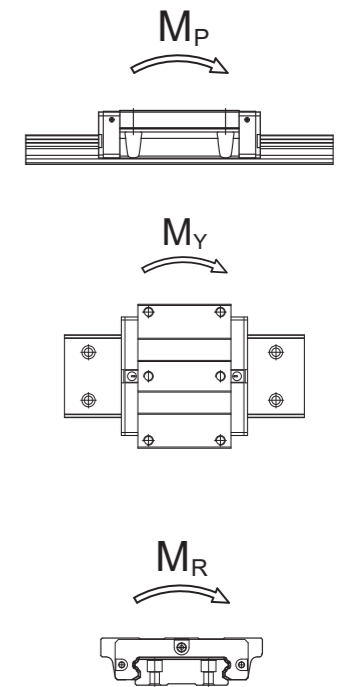

Unit: mm

Model No.	MSG17R	MSG21R	MSG27R	MSG35R
Standard Pitch (P)	40	50	60	80
Standard (E_{std.})	15	15	20	20
Minimum (E_{min.})	5	5	5	7
Max (L_{0 max.})	3 000	3 000	3 000	3 000
Fastening Bolt	M4	M4	M4	M6

TECHNICAL DIMENSIONS

Model No.	External Dimension			Carriage Dimension												
	Height H	Width W	Length L	W ₂	H ₂	B	C	F	S x l	L1	T	N	G	K	d ₁	Grease Nipple
MSG17E	17	60	50.2	13.5	2.5	53	26	18	M4x6	33.6	4.7	4.15	4	2.5	2.4	G-M3
MSG21E	21	68	59	15.5	3	60	29	22	M5x8	40	6	5	12	5.5	2.5	G-M6
MSG27E	27	80	72.2	19	3	70	40	24	M6x10	51.8	8	6	12	6.2	3.3	G-M6
MSG35E	35	120	105.2	25.5	4	107	60	40	M8x14	77.6	11.42	7	12	8.55	3.3	G-M6

Note*: The basic dynamic load rating C of ball type is based on the 50 km for nominal life. The conversion between C for 50 km and C₁₀₀ for 100 km = is C = 1.26x C₁₀₀. Singel carriage only. Double: Double carriage closely contacting with each other.

Note*: Single: Single carriage / Double: double carriages closely contacting with each other.

SPECIFICATIONS

Model No.	Rail Dimension				Basic Load Rating		Static Moment Rating				Weight			
	Width W ₁	Height H ₁	Pitch P	E Std.	D x h x d	Dynamic C kN	Static C ₀ kN	M _p kN-m		M _y kN-m		M _r k-Nm	Carriage kg	Rail kg/m
								Single*	Double*	Single*	Double*			
MSG17E	33	9	40	15	7.5x5.3x4.5	4.8	8.6	0.05	0.24	0.05	0.24	0.14	0.14	2.02
MSG21E	37	11	50	15	7.5x5.3x4.5	7	12.1	0.08	0.46	0.08	0.46	0.22	0.25	2.86
MSG27E	42	15	60	20	7.5x5.3x4.5	12.4	20.2	0.15	0.87	0.15	0.87	0.42	0.31	4.49
MSG35E	69	19	80	20	11x9x7	30.7	48.6	0.65	3.6	0.65	3.6	1.67	0.99	9.4

Roller guide rail MSR-E/LE flange type carriage

The MSR-E/LE is a carriage with flange. This carriage is available in two different lengths, normal (MSR-E) or long (MSR-LE).

Fastening holes are accessible either from top (S1) or bottom (S2). The MSR-Series is specially suited for high precision and high rigidity required motion, for high and very high load.

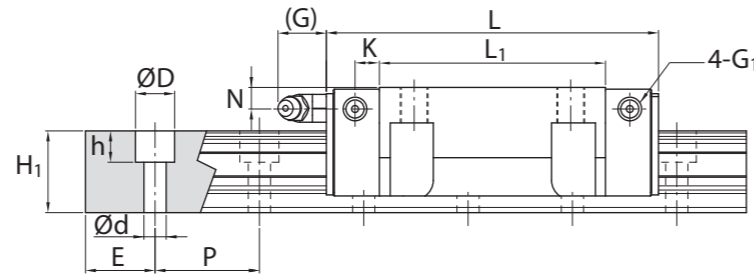
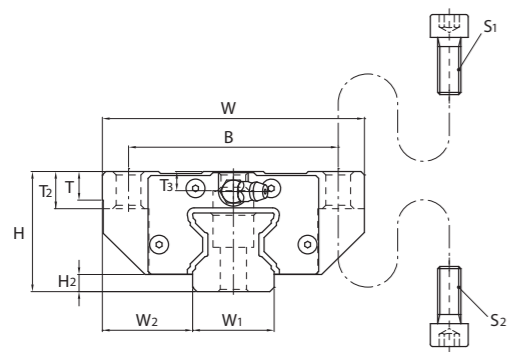
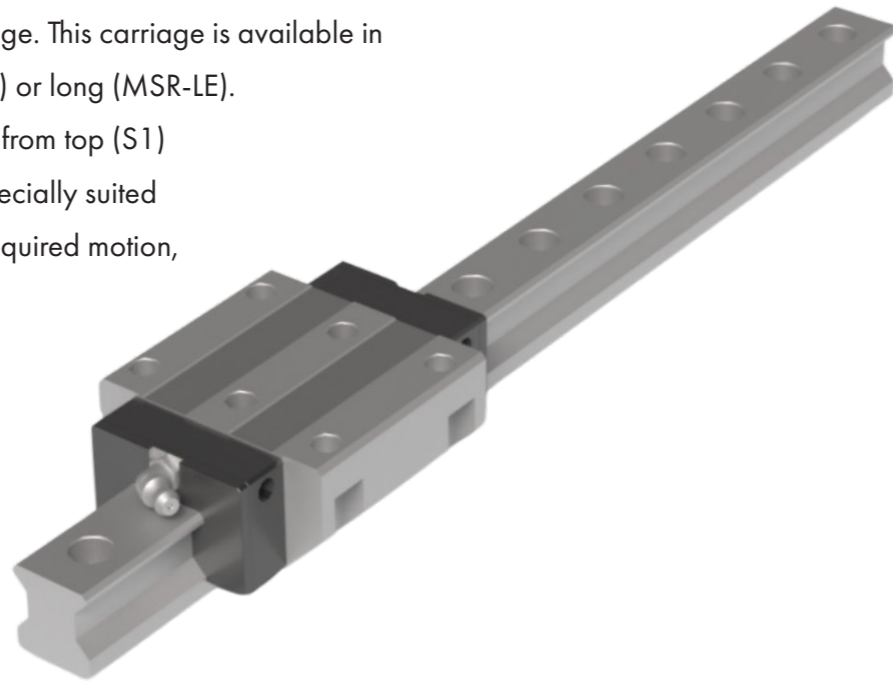

Compact Type, MSR Series

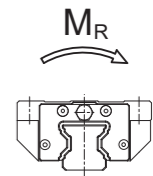
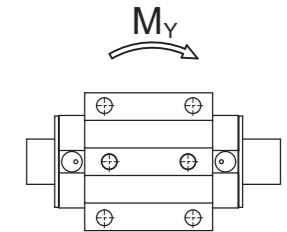
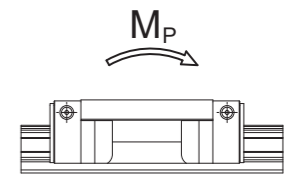
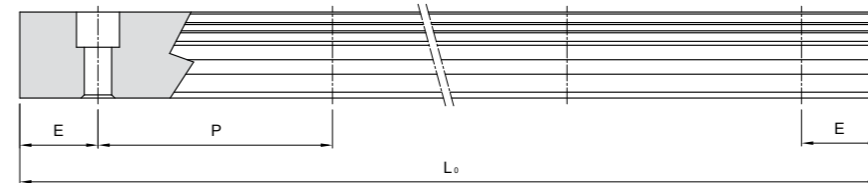
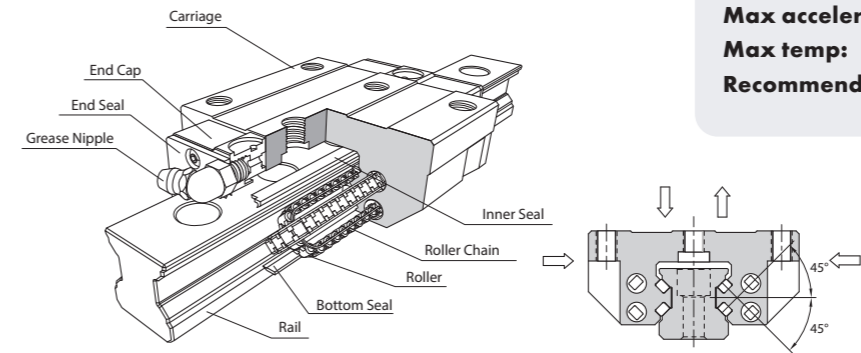

TECHNICAL PRODUCT SPECIFICATION

- Preload:** 7 % of dynamic load capacity
- Max speed:** 2 m/s
- Max acceleration:** 10 m/s²
- Max temp:** 80° Celsius
- Recommended load:** Max. 25 % of dynamic and moment rating

Unit: mm

Model No.	MSR25R	MSR30R	MSR35R	MSR45R	MSR55R	MSR65R
Standard Pitch (P)	30	40	40	52.5	60	75
Standard (E_{std.})	20	20	20	22.5	30	35
Minimum (E_{min.})	7	8	8	11	13	14
Max (L₀ max.)	4 000	4 000	4 000	4 000	4 000	4 000
Fastening Bolt	M6	M8	M8	M12	M14	M16

TECHNICAL DIMENSIONS

Model No.	External Dimension			Carriage Dimension																
	Height H	Width W	Length L	W ₂	H ₂	B	C	C ₂	S	L ₁	T	T ₁	T ₂	T ₃	N	G	K	e ₁	G ₁	Grease Nipple
MSR25E	36	70	97.5	23.5	4.8	57	45	40	M8	65.5	9.5	20.2	10	5.8	6	12	6.6	6.5	M6	G-M6
MSR25LE			115.5							83.5										
MSR30E	42	90	112.4	31	6	72	52	44	M10	75.9	10	21.6	13	6.7	7	12	8	7	M6	G-M6
MSR30LE			135.2							98.7										
MSA35E	48	100	125.3	33	6.5	82	62	52	M10	82.3	12	27.5	15	9.5	8	12	8	7	M6	G-M6
MSA35LE			153.5							110.5										
MSR45E	60	120	154.2	37.5	8	100	80	60	M12	106.5	14.5	35.5	15	12.5	10	13.5	10	8	M6	G-PT 1/8
MSR45LE			189.4							141.7										
MSR55E	70	140	185.4	43.5	10	116	95	70	M14	129.5	17.5	41	18	15.5	11	13.5	12	7.95	M6	G-PT 1/8
MSR55LE			235.4							179.5										
MSR65E	90	170	238.4	53.5	12	142	110	82	M16	168	19.5	56	20	16.5	13.5	12	8	M6	G-PT 1/8	
MSR65LE			300.4							230										

Note*: Singel: Single carriage / Double: Double carriages closely contacting with each other.

SPECIFICATIONS

Model No.	Rail Dimension				Basic Load Rating		Static Moment Rating				Weight		
	Width W ₁	Height H ₁	Pitch P	E Std.	D x h x d	Dynamic C kN	Static C ₀ kN	M _p kN-m	M _y kN-m	M _r kN-m	Carriage kg	Rail kg/m	
MSR25E	23	23.5	30	20	11x9x7	29.6	63.8	0.65	3.82	0.65	3.82	0.73	3.5
MSR25LE								1.08	5.94	1.08	5.94	0.95	
MSR30E	28	27.5	40	20	14x12x9	42.8	91.9	1.09	6.38	1.09	6.38	1.27	5
MSR30LE								1.96	10.60	1.96	10.60	1.75	
MSA35E	34	30.5	40	20	14x12x9	57.9	123.5	1.59	9.56	1.59	9.56	2.09	7
MSR35LE								2.94	16.18	2.94	16.18	2.85	
MSR45E	45	37	52.5	22.5	20x17x14	92.8	193.8	3.28	18.76	3.28	18.76	4.40	11.2
MSR45LE								5.90	31.32	5.90	31.32	5.94	
MSR55E	53	43	60	30	23x20x16	132.8	270.0	5.49	31.18	5.49	31.18	7.33	15.6
MSR55LE								10.60	55.58	10.60	55.58	10.28	
MSR65E	63	52	75	35	26x22x18	205.1	422.7	11.81	59.25	11.81	59.25	13.71	22.4
MSR65LE								22.50	117.87	22.50	117.87	20.02	

MSC-M - Miniature standard type

The MSC-M is a narrow square type of miniature carriage.

Both the rail and carriage are made of stainless steel.

Fastening holes are only accessible from the top.

The MSC-Series is specially suited for small applications for high precision, for light load.

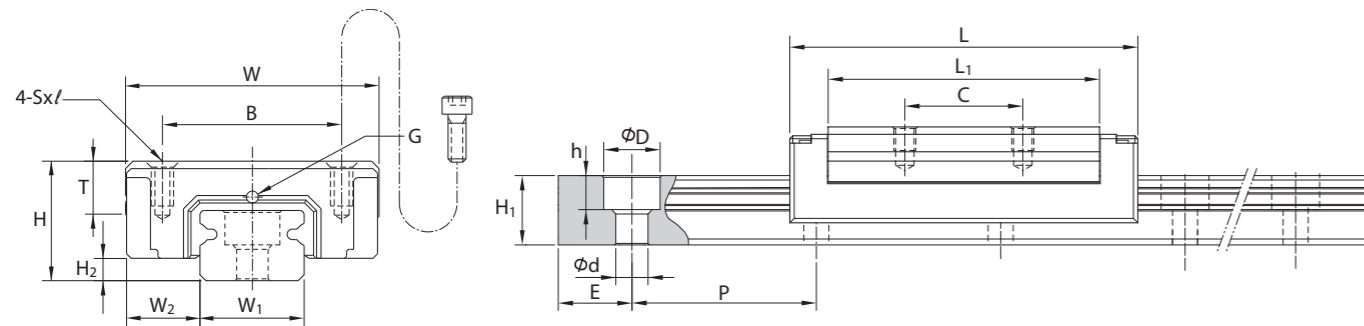
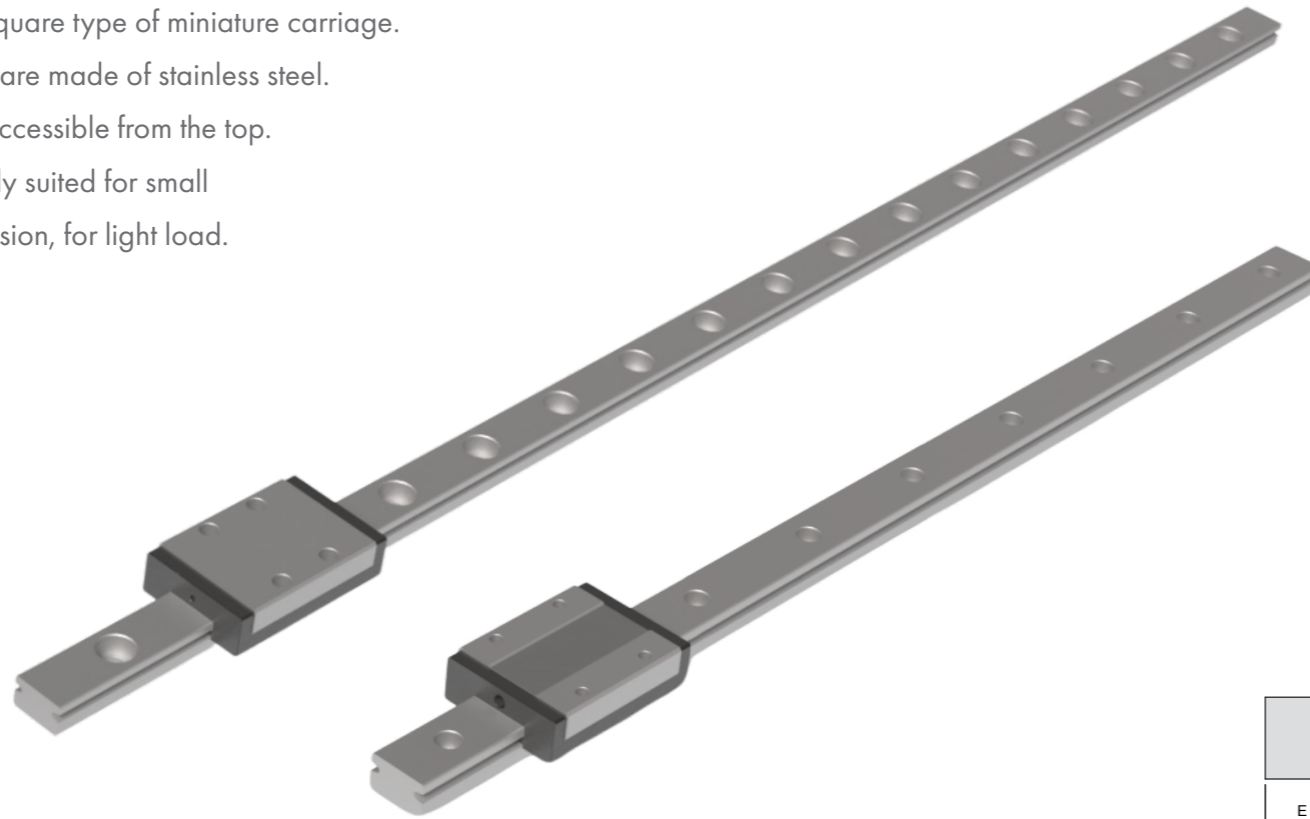

TECHNICAL DIMENSIONS

Model No.	External dimension					Carriage dimension					
	Height H	Width W	Length L	W ₂	H ₂	B	C	S x I	L ₁	T	G
MSC7M	8	17	23.6	5	1.5	12	8	M2x2.5	18.4	3.5	Ø 0.8
MSC9M	10	20	31.1	5.5	2.2	15	10	M3x3	25.8	4.5	Ø 1
MSC12M	13	27	34.6	7.5	3	20	15	M3x3.6	28	6	Ø 1.5
MSC15M	16	32	43.5	8.5	4	25	20	M3x4.2	36.1	7	G-M3

TECHNICAL PRODUCT SPECIFICATION

Preload:	0 %, No play
Max speed:	1 m/s
Max acceleration:	2.5 m/s ²
Max temp:	80° Celsius
Recommended load:	Max. 25 % of dynamic and moment rating

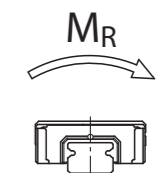
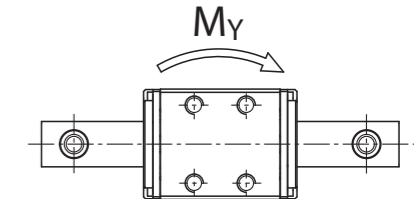
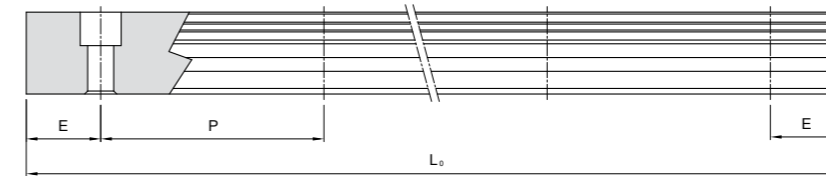
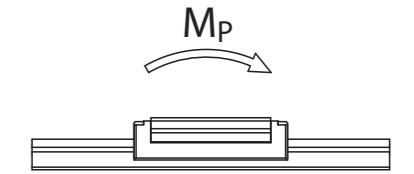

Model No.	Unit: mm			
	MSC7R	MSC9R	MSC12R	MSC15R
Standard Pitch (P)	15	20	25	40
Standard (E_{std.})	5	7.5	10	15
Max (L₀ max.)	490	495	1 000	1 000
Fastening Bolt	M2	M3	M3	M3

SPECIFICATIONS

Model No.	Rail Dimension					Basic Load Rating		Static Moment Rating				Weight		
	Width W ₁	Height H ₁	Pitch P	E Std.	D x h x d	Dynamic C _N	Static C ₀	M _p Nm	M _y Nm	M _r Nm	Carriage g	Rail kg/m		
								Single*	Double*	Single*	Double*			
MSC7M	7	4.7	15	5	4.2x2.3x2.4	940	1 280	2.6	15.33	2.6	15.33	4.7	13	0.22
MSC9M	9	5.5	20	7.5	6x3.3x3.5	1 710	2 240	6.1	33.46	6.1	33.46	10.8	29	0.33
MSC12M	12	7.5	25	10	6x4.5x3.5	2 620	3 520	11.4	63.96	11.4	63.96	22.2	40	0.63
MSC15M	15	9.5	40	15	6x4.5x3.5	4 520	5 700	24.7	132.17	24.7	132.17	44.4	71	1.02

Note *: Single Carriage only. Double: Double Carriage closely contacting with each other.

Article numbers for the products

Rails and carriage configuration. The chart below describes how to configure the rail and carriage. Use the complete configuration code when ordering.

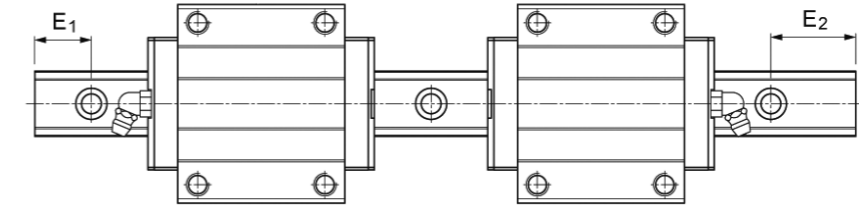

Code for complete rail and carriage

MSA 25 E 2 SS FC +R 1200 -20 / 40 N

Series: MSA, MSB, MSC, MSG, MSR

Size: 7, 9, 12, 15, 20, 25, 30, 35, 45, 55, 65

Carriage type: E: Flange type, mounting either from top or bottom

S: Square type, mounting only from the top

LE: Long flange type, mounting either from top or bottom

LS: Long square type, mounting only from the top

TE: Short flange type, mounting either from top or bottom

TS: Short square type, mounting only from the top

M: Standard miniature type (stainless), mounting only from top

Number of carriages per rail: 1, 2, 3 ...

Dust protection option of carriage: UU, SS, ZZ, DD, KK, LL (only MSC) (see page 16)

Preload: FC (light preload 2%), FZ (preload 0%, only MSC)

Code of special carriage: No symbol (standard), M (stainless), SL (with SL unit)

Rail type: R (hole from the top), T (hole from the bottom), XX Hard Chrome Rail

Rail length: (mm)

Rail hole pitch from start side: E1 (see page 15)

Rail hole pitch from start side: E2 (see page 15)

Accuracy grade: N (Normal)

Code of special rail: No symbol (standard), NM (Stainless)

Dust protection option of rail: No symbol (Plastic cap, standard), CC (Cover strip)

Code for carriage

MSA 25 E SS FC N

Series: MSA, MSB, MSC, MSG, MSR

Size: 7, 9, 12, 15, 20, 25, 30, 35, 45, 55, 65

Carriage type: E: Flange type, mounting either from top or bottom

S: Square type, mounting only from the top

LE: Long flange type, mounting either from top or bottom

LS: Long square type, mounting only from the top

TE: Short flange type, mounting either from top or bottom

TS: Short square type, mounting only from the top

M: Standard miniature type (stainless), mounting only from top

Dust protection option of carriage: No symbol, UU, SS, ZZ, DD, KK, LL (only MSC) (see page 16)

Preload: FC (light preload 2%), FZ (preload 0%, only MSC)

Accuracy grade: N (Normal)

Code of special carriage: No symbol (standard), M (stainless), SL (with SL unit)

Code for rail

MSA 25 R 1200 -20 / 40 N

Series: MSA, MSB, MSC, MSG, MSR

Size: 7, 9, 12, 15, 20, 25, 30, 35, 45, 55, 65

Rail type: R (Counter bore type, hole from the top)

Rail length: (mm)

Rail hole pitch from start side: E1 (see above drawing)

Rail hole pitch from start side: E2 (see above drawing)

Accuracy grade: N (Normal), NM (Normal, stainless only MSC)

Code of special rail: No symbol (standard), NM (Stainless)

Dust protection option of rail: No symbol (Plastic cap, standard), CC (Cover strip)

Seals and metal scrapers

We offer a range of different seals and metal scrapers for our MSA and MSB-series of carriages. SS-seal version is always standard on our carriages but you can choose different if needed. Extra seals (DD) are used in very dirty environments and metal scraper (ZZ) is used in welding environments or when you would like to protect the rubber seal from sharp edges.

End seal

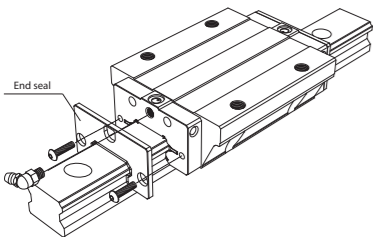

Bidirectional seal when high dust protection is required.

Bottom seal

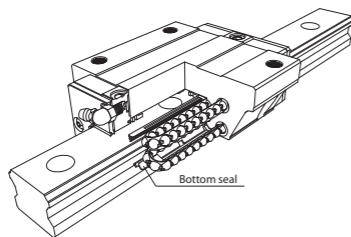

Preventing the inclusion of foreign matters from bottom of carriage.

Metalscraper

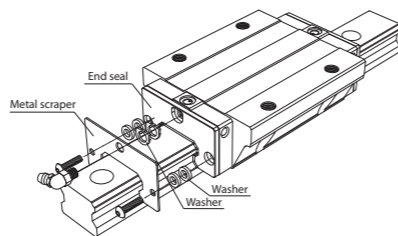

Removing spatters, iron chips, and large foreign matters as well as protecting the end seals.

Code of contamination protection for carriage

Code	Contamination Protection
No symbol	Metalscraper (both ends)
UU	Bidirectional end seal (both ends)
SS	Bidirectional end seal + Bottom seal (Standard)
ZZ	SS + Metalscraper
DD	Double bidirectional end seal + Bottom seal
KK	DD + Metalscraper
LL	Low friction end seal (only MSC)

In the MSA, MSB, MSG and MSR tables below you can see how much the different seal combinations add in length over standard length on the carriage.

Types of seal to the increment to the carriage overall length.

MSA series

Unit: mm

Model No.	No symbol	UU	SS	ZZ	DD	KK
15	1	-	-	6	5	11
20	1.4	-	-	7	5.6	12.6
25	1.4	-	-	7	5.6	12.6
30	1.4	-	-	7	5.6	12.6
35	0.6	-	-	7.8	7.2	15
45	0.6	-	-	7.8	7.2	15

MSG series

Unit: mm

Model No.	No symbol	UU	SS	ZZ	DD	KK
17	-	-	-	6	6	12
21	-	-	-	6	6	12
27	1	-	-	7	6	13
35	1.8	-	-	7.8	6	13.8

MSB series

Unit: mm

Model No.	No symbol	UU	SS	ZZ	DD	KK
15	-	-	-	5	5	10
20	1	-	-	7	6	13
25	1	-	-	7	6	13
30	1	-	-	7	6	13
35	0.6	-	-	7.8	7.2	15

MSR series

Unit: mm

Model No.	No symbol	UU	SS	ZZ	DD	KK
25	-	-	-	6	6	12
30	1	-	-	7	6	13
35	1	-	-	7	6	13
45	0.6	-	-	7	6.4	13.4
55	0.6	-	-	7.8	7.2	15
65	-0.2	-	-	7.8	8	15.8

CC - Cover strip

A specially designed cover strip is used to cover the bolt hole to prevent foreign particles from entering the carriage. Article number for cover strip is CC. End mounting units (2 pcs) is included in the cover strip when ordering.

MSA, MSB series

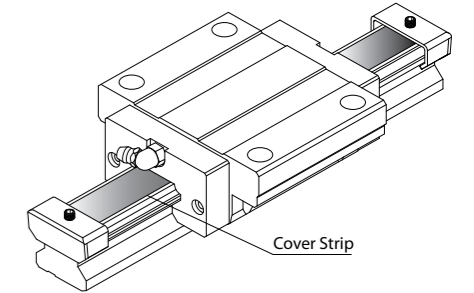

Coverstrip is available for serie MSA-serie 15 – 45 and MSB size 15 – 35.

Grease nipples

The standard lubrication fitting is grease nipple (G-M6, G-PT1/8, G-M4). The code for different types of lubrication fittings are shown below. For cases other than specified, please contact us for information.

G-M6

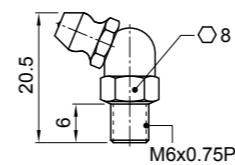

GS-M6

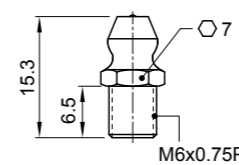

G-PT1/8

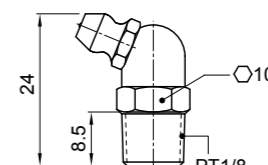

GS-PT1/8

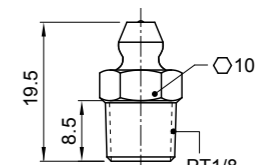

G-M4

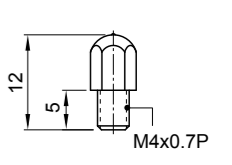

OS-A

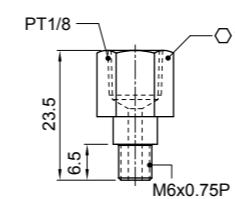

OS-B

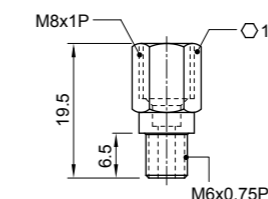

OS-C

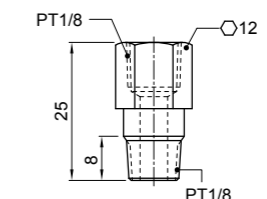

OS-D

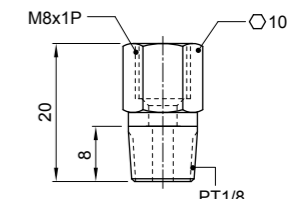

The standard mounting location on the carriage is at the center of both ends. As shown below, lubrication from the side of the carriage is achieved by using an adapter to connect the grease/oil fitting to the hole on the carriage.

Lubrication position

The standard mounting location on the carriage is at the center of both ends. As shown below, lubrication from the side of the carriage is achieved by using an adapter to connect the grease/oil fitting to the hole on the carriage.

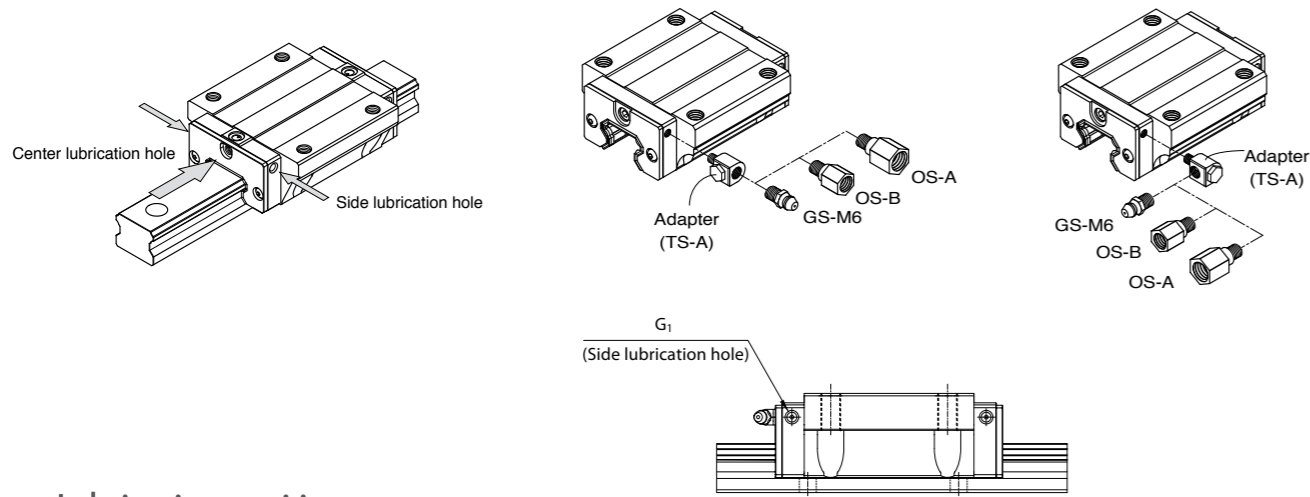

Lubrication position

Model No.			Grease Nipple		Piping Joint				Side Standard	
			Standard	Option	Center Option	Side Option		G ₁	Nipple	
		MSG17	G-M3	-	-	-	-	M3x0.5P	G-M3	
MSA15	MSB15		G-M4	-	-	-	-	M4x0.7P	G-M4	
MSA20	MSB20	MSG21	G-M6	GS-M6	OS-A	OS-B	OS-A TS-A	OS-B TS-A	M4x0.7P	G-M4
MSA25	MSB25	MSG27							M4x0.7P	G-M4
MSA30	MSB30								M4x0.7P	G-M4
MSA35	MSB35	MSG35							M4x0.7P	G-M4
MSA45			G-PT1/8	GS-PT1/8	OS-C	OS-D	OS-A TS-A	OS-B TS-A	M4x0.7P	G-M4
		MSR25	G-M6	GS-M6	OS-A	OS-B	OS-A TS-A	OS-B TS-A	M6x0.75P	G-M6
		MSR30	G-M6	G-M6	OS-A	OS-B	OS-A TS-A	OS-B TS-A	M6x0.75P	G-M6
		MSR35	G-M6	G-M6	OS-A	OS-B	OS-A TS-A	OS-B TS-A	M6x0.75P	G-M6
		MSR45	G-PT1/8	GS-PT1/8	OS-C	OS-D	OS-A TS-A	OS-B TS-A	M6x0.75P	G-M6
		MSR55	G-PT1/8	GS-PT1/8	OS-C	OS-D	OS-A TS-A	OS-B TS-A	M6x0.75P	G-M6
		MSR65	G-PT1/8	GS-PT1/8	OS-C	OS-D	OS-A TS-A	OS-B TS-A	M6x0.75P	G-M6

SL-Lubrication units

SL-Lubrication unit is designed with an oil reservoir which is equipped with a high-density fiber net. Through the fiber net, the lubricant can be steadily fed onto the surface of the rail to satisfy the required lubricating function. SL-Lubrication units can be mounted on carriage series MSA, MSB and MSR.

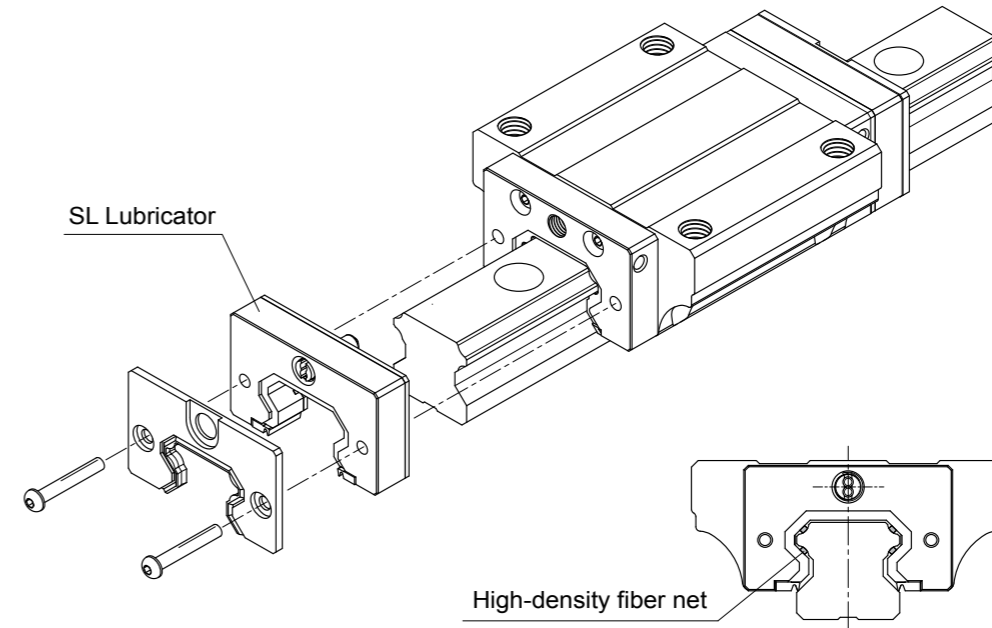

By using the SL Lubricator, the interval between maintenance work can be lengthened at all load ratings.

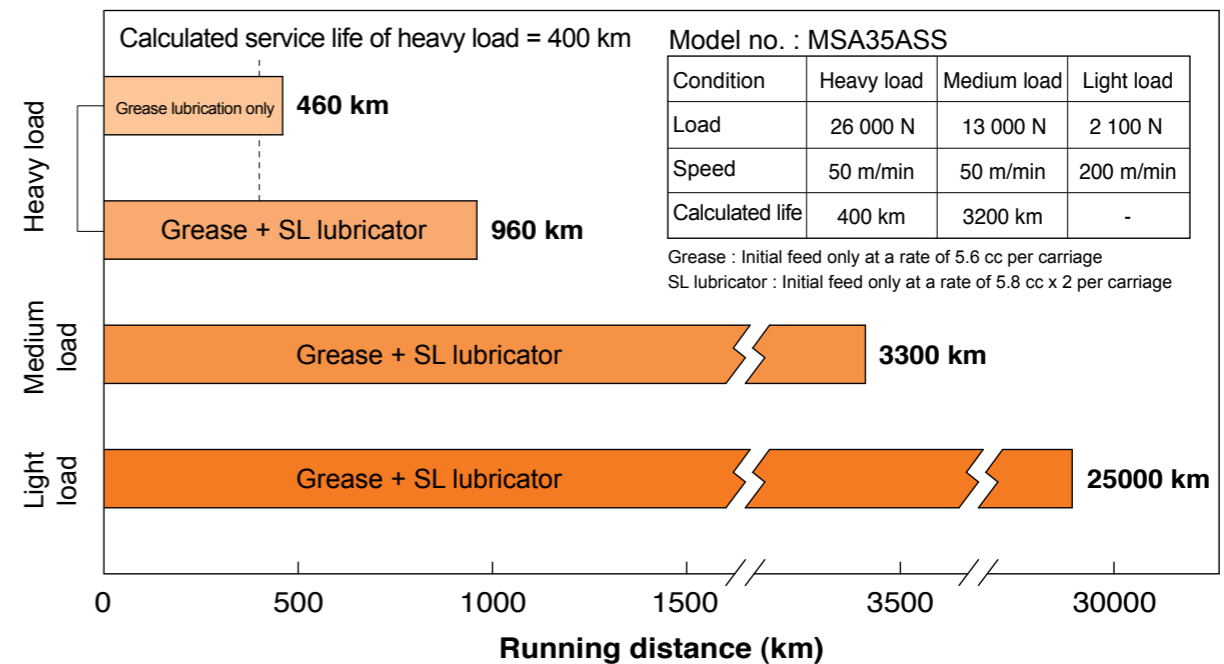

Length including SL-unit on carriage.

MSA series

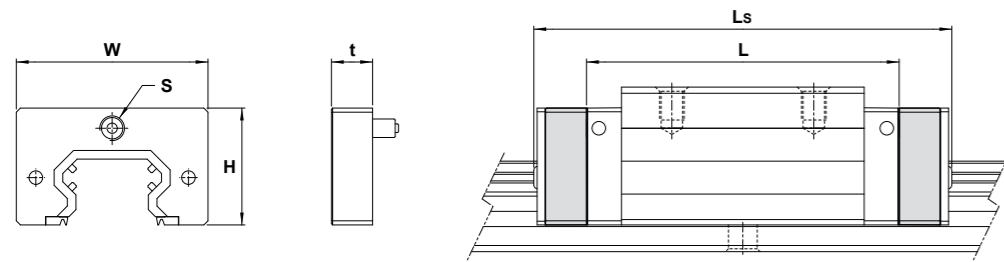

Model No.		SL Lubricator dimension (mm)				Carriage dimension (mm)	
		Height H	Width W	Thickness t	Tapped hole S	Standard length L	SL Lubricator overall length Ls
MSA15SL	E/S	19	31.2	10	M4	56.3	81.3
MSA20SL	E/S LE/LS	21.2	42.8	10	M6	72.9 88.8	92.9 108.8
MSA25SL	E/S LE/LS	28.5	46.8	10	M6	81.6 100.6	101.6 120.6
MSA30SL	E/S LE/LS	32	57	10	M6	97 119.2	117 139.2
MSA35SL	E/S LE/LS	36.5	68	10	M6	111.2 136.6	131.2 156.6
MSA45SL	E/S LE/LS	49	83.6	15	1/8PT	137.7 169.5	167.7 199.5

MSB series

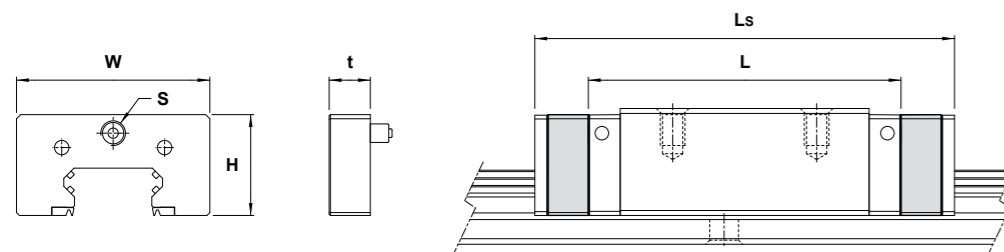

Model No.		SL Lubricator dimension (mm)				Carriage dimension (mm)	
		Height H	Width W	Thickness t	Tapped hole S	Standard length L	SL Lubricator overall length Ls
MSB15SL	TE/TS E/S	18.5	33	10	M4	40 57	65 82
MSB20SL	TE/TS E/S	21.2	40.8	10	M6	48 67	68 84
MSB25SL	TE/TS E/S	24.5	47	10	M6	60.2 82	80.2 102
MSB30SL	TE/TS E/S	30.8	57	10	M6	68 96.7	88 116.7

Length including SL-unit on carriage.

MSR series

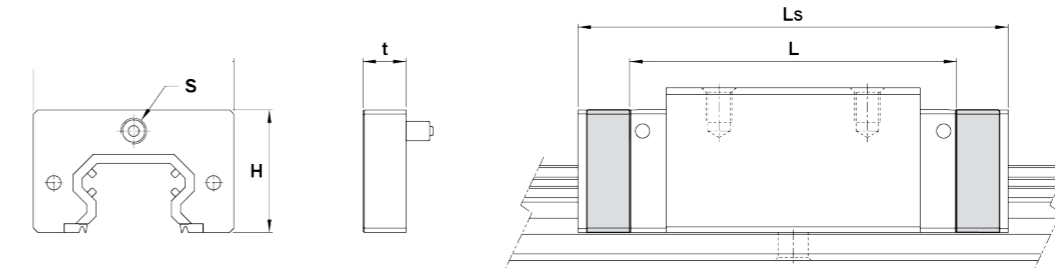

Model No.		SL Lubricator dimension (mm)				Carriage dimension (mm)	
		Height H	Width W	Thickness t	Tapped hole S	Standard length L	SL Lubricator overall length Ls
MSR25SL	E/S LE/LS	30.2	47	10	M6	91.5 109.5	117.5 135.5
MSR30SL	E/S LE/LS	34.5	58.6	10	M6	106.4 129.2	132.4 155.2
MSR35SL	E/S LE/LS	40.5	69	10.3	M6	119.3 147.5	145.9 174.1
MSR45SL	E/S LE/S	50.9	84	15.3	1/8PT	147.8 183	184.8 220
MSR55SL	E/S LE/S	58.5	98	15.3	1/8PT	178.2 228.2	216 266
MSR65SL	LE/S	76.5	122	15	1/8PT	292.6	330.4

Lubrication advice

A good lubrication is important for maintaining the function of the linear guideway. If the lubrication is not sufficient, the frictional resistance at the rolling area will increase and the service life will be shortened as a result of wearing of rolling parts. Two primary lubricants, grease and oil, are used for linear motion system. The lubrication methods are categorized into manual or forced oiling. The selection of lubricant and its method should be based on the consideration of operating speed and environment requirement.

Grease lubrication

The grease feeding interval will vary with different operating conditions and environments. Under normal operating condition, the grease should be replenished every 100 km of travel. The standard grease is

lithium-based. In most cases alvania grease (AV2) is recommended. Moving the carriage back and forth with a minimum stroke length of length of 3 carriages after the carriages have been greased. To assure the grease is evenly distributed inside of carriage, the mentioned process should be repeated twice at least.

Oil lubrication

The recommended viscosity of oil is 30–150 cst. Installation other than horizontal may unable the oil to reach raceway area. Please specify the direction your linear guideway will be applied.

Accuracy on rail and carriage

Accuracy of MSA and MSB series

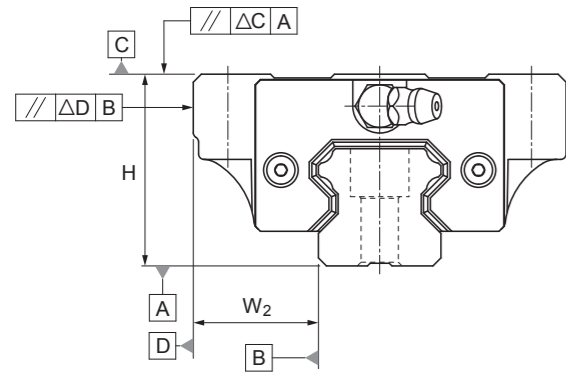

Model No.	Item	Accuracy Grade
		Normal N
15 20	Tolerance for height H	± 0.1
	Height difference ΔH	0.02
	Tolerance for distance W ₂	± 0.1
	Difference in distance W ₂ (ΔW ₂)	0.02
	Running parallelism of surface C with surface A	ΔC (see *table 1)
	Running parallelism of surface D with surface B	ΔD (see *table 1)
25 30 35	Tolerance for height H	± 0.1
	Height difference ΔH	0.02
	Tolerance for distance W ₂	± 0.1
	Difference in distance W ₂ (ΔW ₂)	0.03
	Running parallelism of surface C with surface A	ΔC (see *table 1)
	Running parallelism of surface D with surface B	ΔD (see *table 1)
45 55	Tolerance for height H	± 0.1
	Height difference ΔH	0.03
	Tolerance for distance W ₂	± 0.1
	Difference in distance W ₂ (ΔW ₂)	0.03
	Running parallelism of surface C with surface A	ΔC (see *table 1)
	Running parallelism of surface D with surface B	ΔD (see *table 1)
65	Tolerance for height H	± 0.1
	Height difference ΔH	0.03
	Tolerance for distance W ₂	± 0.1
	Difference in distance W ₂ (ΔW ₂)	0.03
	Running parallelism of surface C with surface A	ΔC (see *table 1)
	Running parallelism of surface D with surface B	ΔD (see *table 1)

Rail length (mm)		Running Parallelism Values (μm)
Above	Or less	N
0	315	9
315	400	11
400	500	13
500	630	16
630	800	18
800	1 000	20
1 000	1 250	22
1 250	1 600	25
1 600	2 000	28
2 000	2 500	30
2 500	3 000	32
3 000	3 500	33
3 500	4 000	34

*Table 1

Accuracy of MSC series

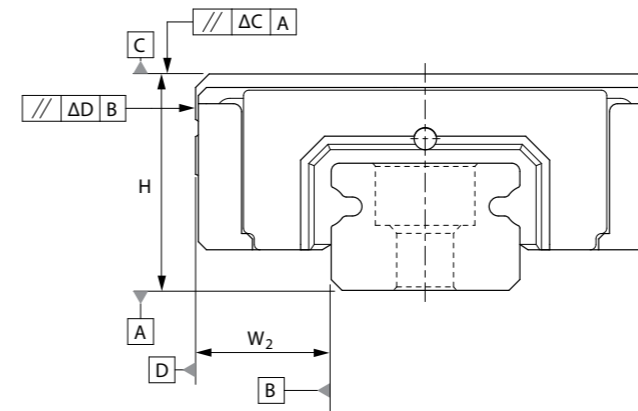

Model No.	Item	Accuracy Grade
		Normal N
7 9 12 15	Tolerance for height H	± 0.04
	Height difference ΔH	0.03
	Tolerance for distance W ₂	± 0.04
	Difference in distance W ₂ (ΔW ₂)	0.03
	Running parallelism of surface C with surface A	ΔC (see *table 2)
	Running parallelism of surface D with surface B	ΔC (see *table 2)

Rail length (mm)		Running Parallelism Values (μm)
Above	Or less	N
-	40	8
40	70	10
70	100	11
100	130	12
130	160	13
160	190	14
190	220	15
220	250	16
250	280	17
280	310	17
310	340	18
340	370	18
370	400	19
400	430	20
430	460	20
460	490	21
490	520	21

*Table 2

Rail length (mm)		Running Parallelism Values (μm)
Above	Or less	N
520	550	22
550	580	22
580	610	22
610	640	22
640	670	23
670	700	23
700	730	23
730	760	23
760	790	23
790	820	23
820	850	24
850	880	24
880	910	24
910	940	24
940	970	24
970	1 000	25

*Table 2

Accuracy of MSG series

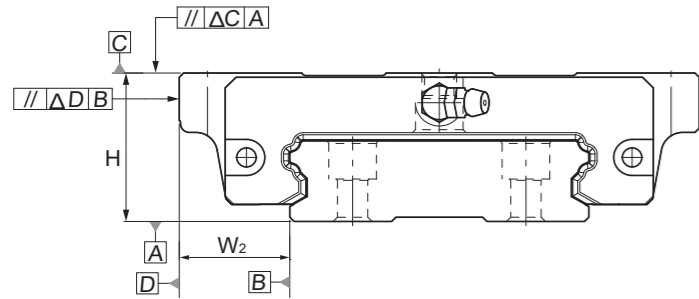

Model No.	Item	Accuracy Grade		
		Normal N	High H	Precision P
17 20	Tolerance for height H	± 0.1	± 0.03	0 -0.03
	Tolerance for distance W ₂	± 0.1	± 0.03	0 -0.03
	Height difference (ΔH)	0.02	0.01	0.006
	Difference in distance W ₂ (ΔW ₂)	0.02	0.01	0.006
	Running parallelism of surface C with surface A	ΔC (see *table 3)		
	Running parallelism of surface D with surface B	ΔC (see *table 3)		
27 35	Tolerance for height H	± 0.1	± 0.04	0 -0.04
	Tolerance for distance W ₂	± 0.1	± 0.04	0 -0.04
	Height difference (ΔH)	0.02	0.015	0.007
	Difference in distance W ₂ (ΔW ₂)	0.03	0.015	0.007
	Running parallelism of surface C with surface A	ΔC (see *table 3)		
	Running parallelism of surface D with surface B	ΔC (see *table 3)		

Rail length (mm)		Running Parallelism Values (μm)
Above	Or less	N
0	315	9
315	400	11
400	500	13
500	630	16
630	800	18
800	1000	20
1000	1250	22
1250	1600	25
1600	2000	28
2000	2500	30
2500	3000	32
3000	3500	33
3500	4000	34

*Table 3

Accuracy of MSR series

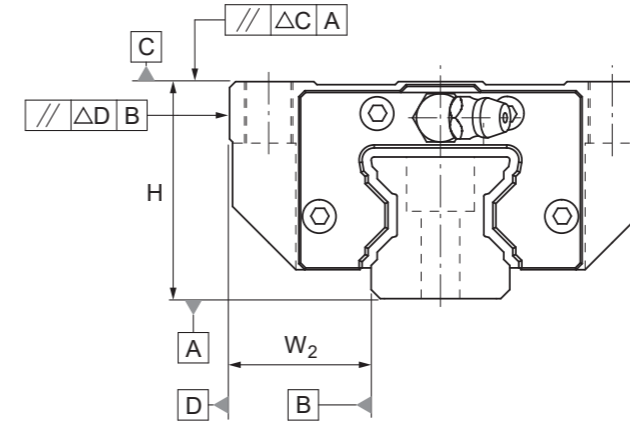

Model No.	Item	Accuracy Grade	
		Normal N	High H
20 25 30 35	Tolerance for height H	± 0.04	0 ± 0.02
	Tolerance for distance W ₂	± 0.04	0 - 0.04
	Height difference (ΔH)	0.015	0.007
	Difference in distance W ₂ (ΔW ₂)	0.015	0.007
	Paired multiple-rail height difference (ΔH)	0.07	0.04
	Running parallelism of surface C with surface A	ΔC (see *table 4)	
	Running parallelism of surface D with surface B	ΔC (see *table 4)	
	45 55	Tolerance for height H	± 0.05
Tolerance for distance W ₂		± 0.05	0 -0.05
Height difference (ΔH)		0.015	0.007
Difference in distance W ₂ (ΔW ₂)		0.02	0.01
Running parallelism of surface C with surface A		ΔC (see *table 4)	
Running parallelism of surface D with surface B		ΔC (see *table 4)	
65	Tolerance for height H	± 0.07	0 -0.07
	Tolerance for distance W ₂	± 0.07	0 -0.07
	Height difference (ΔH)	0.02	0.01
	Difference in distance W ₂ (ΔW ₂)	0.025	0.015
	Running parallelism of surface C with surface A	ΔC (see *table 4)	
	Running parallelism of surface D with surface B	ΔC (see *table 4)	

Rail length (mm)		Running Parallelism Values (μm)
Above	Or less	H
0	315	6
315	400	8
400	500	9
500	630	11
630	800	12
800	1000	14
1000	1250	16
1250	1600	18
1600	2000	20
2000	2500	22
2500	3000	24
3000	3500	25
3500	4000	26

*Table 4

Tolerance between two rails - parallel deviation

When mounting two rails that should operate together, it is important that the rails holds the tolerances of parallelism between the two rails as shown below.

The parallel deviation between two rails (e_1).

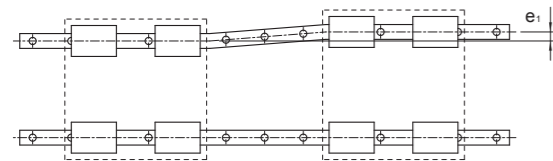

MSA, MSB series

Unit: μm

Model No.	e_1
15	25
20	25
25	30
30	40
35	50
45	60

MSC series

Unit: μm

Model No.	e_1
7	12
9	15
12	20
15	25

The parallel deviation between two rails (e_1).

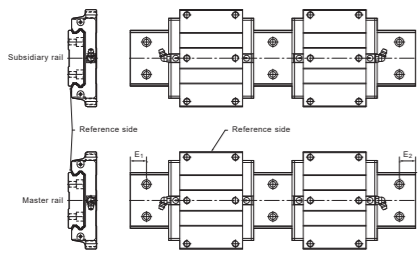

MSG series

Unit: μm

Model No.	e_1
17	25
21	25
27	25
35	30

The parallel deviation between two rails (e_1).

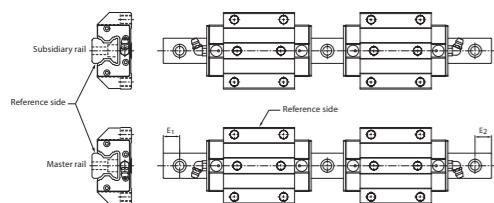

MSR series

Unit: μm

Model No.	e_1
25	9
30	11
35	14
45	17
55	21
65	27

Tolerance between two rails - level difference

When mounting two rails that should operate together, it is important that the surface holds the tolerances of parallelism between the two axes as shown below.

Level difference between two rails (e_2)

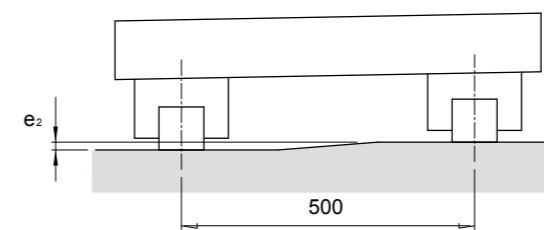

MSA, MSB series

Unit: μm

Model No.	e_2
15	130
20	130
25	130
30	170
35	210
45	250

MSC series

Unit: μm

Model No.	e_2
7	160
9	250
12	300
15	350

Level difference between two rails (e_2)

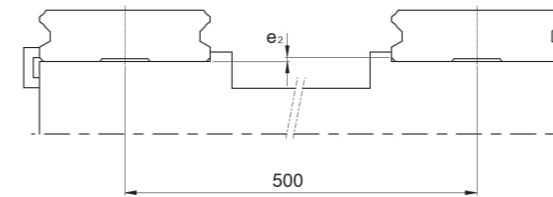

MSG series

Unit: μm

Model No.	e_2
17	130
21	130
27	130
35	130

Level difference between two rails (e_2)

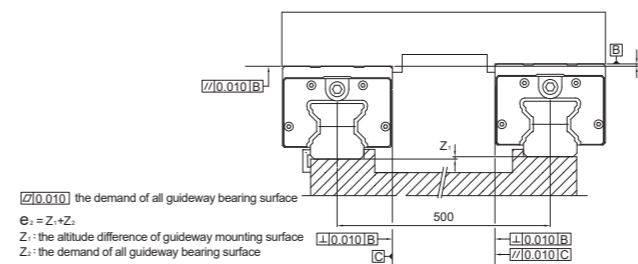

MSR series

Unit: μm

Model No.	e_1
25	150
30	150
35	150
45	150
55	150
65	150

$\sqrt{0.010}$ the demand of all guideway bearing surface
 $e_2 = Z_1 + Z_2$
 Z_1 : the altitude difference of guideway mounting surface
 Z_2 : the demand of all guideway bearing surface

Caps for rail

The plastic cap is mounted by using a plastic hammer with a flat pad placed on the top, until the top of the cap flush to the top surface of the rail. The dimension of plastic caps for each series is shown below. Plastic cap is always included in the rail. (No caps for MSC7R and MSC9R)

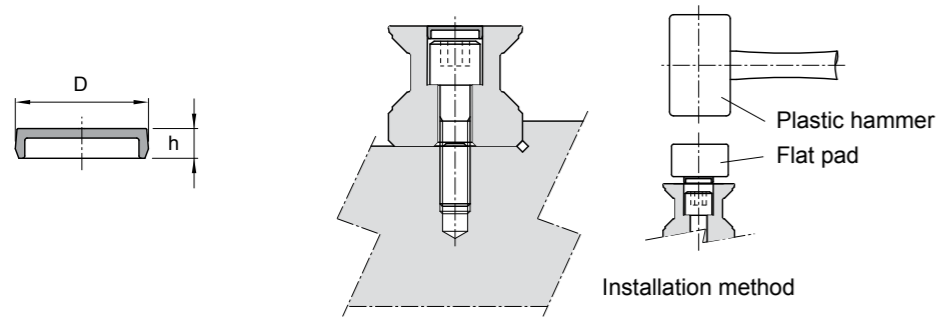

Code of Plastic Cap	D (mm)	h (mm)	Bolt Size	Rail Model			
M3C	6.3	1.1	M3			MSC12R MSC15R	
M4C	7.8	1.1	M4	MSA15R	MSB15U		MSG17R MSG21R MSG27R
M5C	9.8	2.2	M5	MSA20R	MSB20R		MSR20R
M6C	11.3	2.5	M6	MSA25R	MSB25R MSB30R		MSR25R MSG35R
M8C	14.4	3.3	M8	MSA30R MSA35R	MSB35R		MSR30R MSR35R
M12C	20.4	4.6	M12	MSA45R			MSR45R
M14C	23.1	5	M14				MSR55R
M16C	26.2	5	M16				MSR65R

Tightening torque for rails

An improper tightening torque could affect the mounting accuracy. Tightening the bolts with a torque wrench to the specified torque value is highly recommended. Different types of mounting materials, should have different torque value.

Unit: Nm

Bolt model	Torque Value		
	Iron	Cast iron	Aluminum
M2	0.6	0.4	0.3
M3	2	1.3	1
M4	4	2.7	2
M5	8.8	5.9	4.4
M6	13.7	9.2	6.8
M8	30	20	15
M10	68	45	33
M12	120	78	58
M14	157	105	78
M16	196	131	98

Shoulder height

The mounting surface of rails and carriages are machined precisely for positioning and assembling with high accuracy. The shoulder height and corner radius should provide enough mounting space to not interfere with chamfers made on rails and carriages.

The dimensions of shoulder height and corner radius are shown below.

MSA series

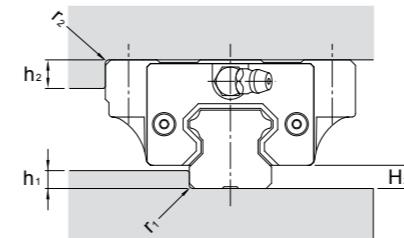

Unit: mm

Model No.	r ₁ (max.)	r ₂ (max.)	h ₁	h ₂	H ₂
15	0.5	0.5	3	4	4.2
20	0.5	0.5	3.5	5	5
25	1	1	5	5	6.5
30	1	1	5	5	8
35	1	1	6	6	9.5
45	1	1	8	8	10

MSB series

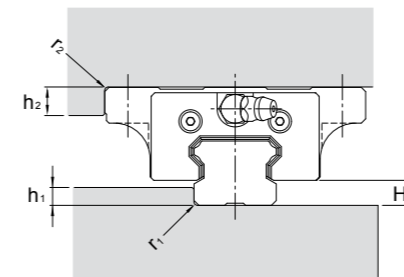

Unit: mm

Model No.	r ₁ (max.)	r ₂ (max.)	h ₁	h ₂	H ₂
15	0.5	0.5	3	4	4.5
20	0.5	0.5	4	5	6
25	1	1	5	5	7
30	1	1	7	5	9.5
35	1	1	8	6	9.5

MSC series

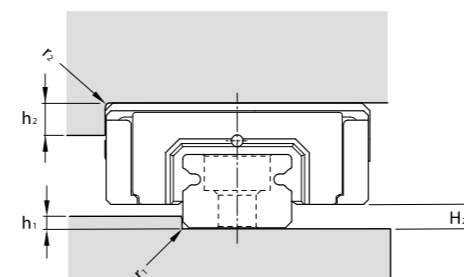

Unit: mm

Model No.	r ₁ (max.)	r ₂ (max.)	h ₁	h ₂	H ₂
7	0.2	0.2	1.0	3	1.5
9	0.2	0.3	1.7	3	2.2
12	0.3	0.4	2.5	4	3.0
15	0.5	0.5	3.5	5	4.0

Shoulder height

MSG series

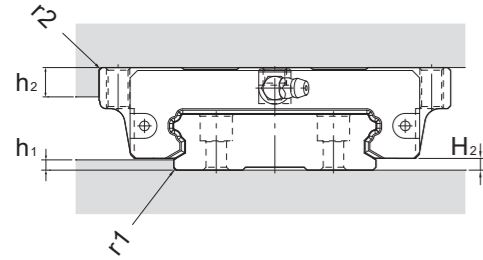

Unit: mm

Model No.	r ₁ (max.)	r ₂ (max.)	h ₁	h ₂	H ₂
17	0.4	0.4	2	5	2.5
21	0.4	0.4	2.5	5	3
27	0.4	0.4	2.5	7	3
35	0.8	0.8	3.5	10	4

MSR series

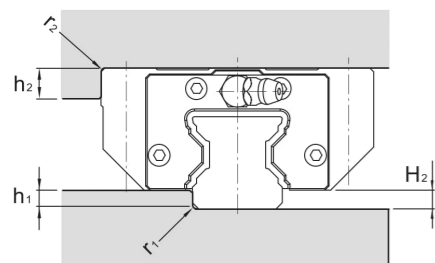

Unit: mm

Model No.	r ₁ (max.)	r ₂ (max.)	h ₁	h ₂	H ₂
25	0.5	0.5	4	8	4.8
30	0.5	0.5	5	8	6
35	1	1	5.5	10	6.5
45	1	1	6	12	8.1
55	1	1	8	15	10
65	1	1	10	15	12

Installation of rail

Installation of parallel rail and carriage.

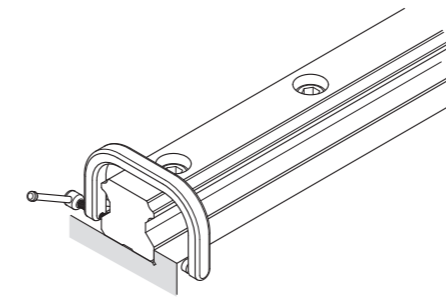
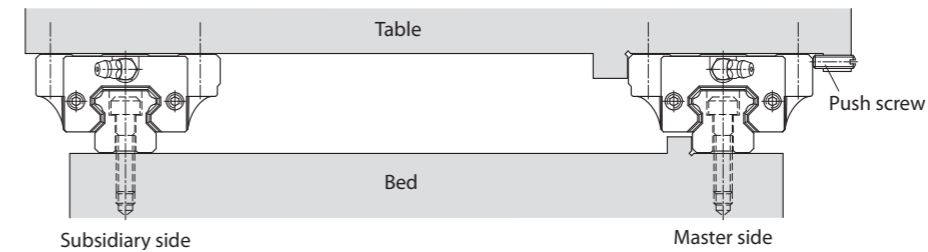

Using a vise

First tighten the mounting bolts temporarily, then use a C vise to press the master rail to reference side. Tighten the mounting bolts in sequence to specified torque.

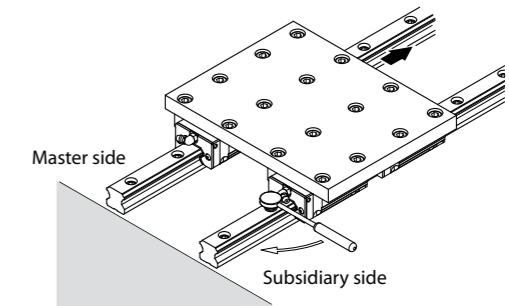

Compare to master rail side

Tighten two master side carriages and one subsidiary side carriage onto the table. Then temporarily tighten another subsidiary carriage and rail to the table and bed. Move the table from one rail, check and align the parallelism of subsidiary rail based on moving resistance. Tighten the bolts in sequence.

Lifetime calculation

Basic Dynamic Load Rating (C)

Even when identical linear guideways are manufactured in the same way or applied under the same condition, the service life may be varied. Thus, the service life is used as an indicator for determining the service life of a linear guideway system. The nominal life (L) is defined as the total running distance that 90% of identical linear guideways, when they are applied under the same conditions, can work without developing aking. The basic dynamic load rating (C) can be used to calculate the service life when linear guideway system response to a load. The basic dynamic load rating (C) is defined as a load in a given direction and with a given magnitude that when a group of linear guideways operate under the same conditions. As the rolling element is ball, the nominal life of the linear guideway is 50 km. Moreover, as the rolling element is roller, the nominal life is 100 km.

Calculation of Nominal Life (L)

The nominal life of a linear guideway can be affected by the actual working load. The nominal life can be calculated based on selected basic dynamic load rating and actual working load. The nominal life of linear guideway system could be influenced widely by environmental factors such as hardness of raceway, environmental temperature, motion conditions, thus these factors should be considered for calculation of nominal life.

$$L = \left(\frac{f_H \times f_T}{f_W} \times \frac{C}{P} \right)^3 \times 50$$

- L** Nominal life (km)
- C** Basic dynamic load rating (N)
- P** Working load (N)
- f_H** Hardness factor
- f_T** Temperature factor
- f_W** Load factor

Hardness factor f_H

In order to ensure the optimum load capacity of linear guideway system, the hardness of raceway must be HRC58~64. If the hardness is lower than this range, the permissible load and nominal life will be decreased. For this reason, the basic dynamic load rating and the basic static load rating should be multiplied by hardness factor for rating calculation. See figure below. The hardness requirement of our linear guideway is above HRC58, thus the $f_H=1.0$.

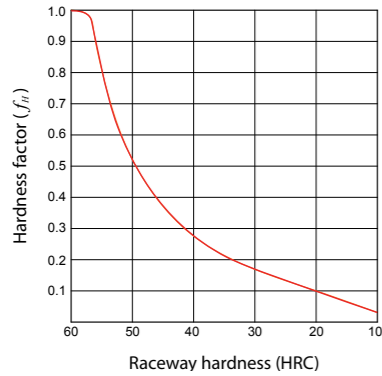

Temperature factor f_T

When operating temperature higher than 80°C, the nominal life will be degraded. Therefore, the basic dynamic and static load rating should be multiplied by temperature factor for rating calculation. See figure below. The assemble parts of our guideway are made of plastic and rubber, therefore, the operating temperature below 80°C is strongly recommend. For special need, please contact us.

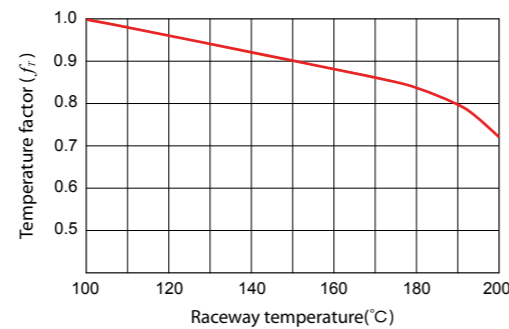

Load factor f_w

Although the working load of linear guideway system can be obtained by calculation, the actual load is mostly higher than calculated value. This is because the vibration and impact, caused by mechanical reciprocal motion, are difficult to estimate. This is especially true when the vibration from high speed operation and the impact from repeated start and stop. Therefore, for consideration of speed and vibration, the basic dynamic load rating should be divided by the empirical load factor (f_w). See the table to the right.

Motion Condition	Operating Speed	f_w
No impact & vibration	$V \leq 15$ m/min	1.0~1.2
Slight impact & vibration	$15 < V \leq 60$ m/min	1.2~1.5
Moderate impact & vibration	$60 < V \leq 120$ m/min	1.5~2.0
Strong impact & vibration	$V \geq 120$ m/min	2.0~3.5

Calculation of service life in time (Lh)

When the nominal life (L) is obtained, the service life in hours can be calculated by using the following equation when stroke length and reciprocating cycles are constant.

$$L_b = \frac{L \times 10^3}{2 \times l_s \times n_1 \times 60}$$

L_b Service life in hours (hr)
 L Nominal life (km)
 l_s Stroke length
 n_1 No. of reciprocating cycles per minute (min^{-1})

Friction on movement

The friction resistance of a linear guideway system can vary with the magnitude of load and preload, the viscosity resistance of lubricant, and other factors. The frictional resistance can be calculated by the following equation based on working load and seal resistance. Generally, the friction coefficient will be different from series to series. The friction coefficient of ball type is 0.003 without considering the seal resistance, shown in table below.

$$F = \mu \times P + f$$

F Frictional resistance (kgf)
 μ Dynamic friction coefficient
 P Working load (kgf)
 f Seal resistance (kgf)

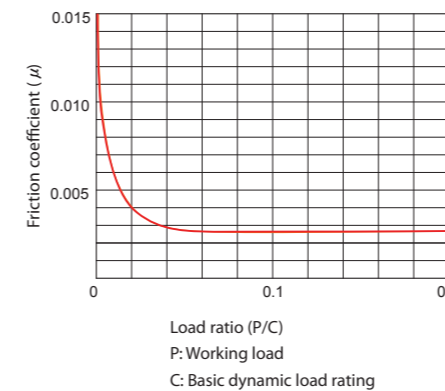

Relationship between working load and friction coefficient.

MSB series

The maximum resistance value of MSB series with seals type UU when it is applied with grease is shown below. Unit: N

Model No.	(f) Seal Resistance
15	2
20	3
25	4
30	5.5
35	9

MSG series

The maximum resistance value of MSG series with seals type UU when it is applied with grease is shown below. Unit: N

Model No.	(f) Seal Resistance
17	2
21	3.5
27	4
35	6

MSA series

The maximum resistance value of MSA series with seals type UU when it is applied with grease is shown below. Unit: N

Model No.	(f) Seal Resistance
15	2
20	3.5
25	4
30	6
35	10
45	12

MSC series

The maximum resistance value of MSC series with seals type LL when it is applied with grease is shown below. Unit: N

Model No.	(f) Seal Resistance
7	0.08
9	0.1
12	0.4
15	0.8

MSR series

The maximum resistance value of MSR series with seals type UU when it is applied with grease is shown below. Unit: N

Model No.	(f) Seal Resistance
25	4.5
30	8
35	12
45	18
55	20
65	35

Your Partner in Automation Solutions



Item Aluminiumprofiles



D30 Tube System



Work Bench System

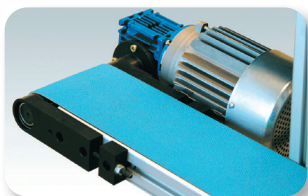

Belt Conveyor System

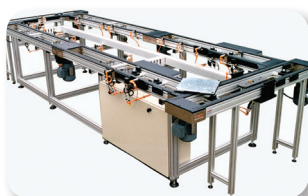

Palette Conveyor System



Lean Production System



Item News Every Year



Ball Bushings

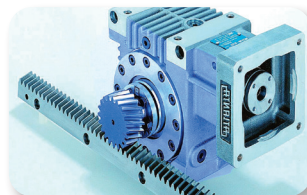

Rack and Pinion System



Compact Rail

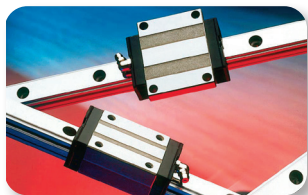

Linear Guides



Ball Screws



Easy Rail



Heavy Telescopic Rail



Light Telescopic Rail



Servo Motors

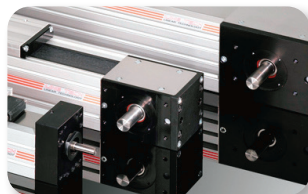

Linear Modules

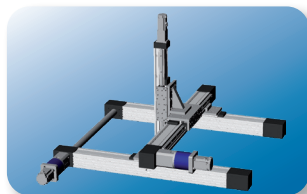

Complete Solutions

AluFlexGroup

YOUR PARTNER IN AUTOMATION SOLUTIONS

AluFlex AB | item profiili oy | LinearModul A/S | AluFlex System AS

AluFlex AB
Lilla Garnisonsgatan 34
254 67 Helsingborg
Tel +46 42 38 02 30
Fax +46 42 38 02 31
orders@aluflex.se
www.aluflex.se

LinearModul A/S
Sivlandvænget 13 B
5260 Odense S
Tel +45 65 91 72 10
Fax +45 65 91 72 20
orders@linearmodul.dk
www.linearmodul.dk

AluFlex System AS
Energivegen 14
Postboks 428
2051 Jessheim
Tlf +47 63 94 49 20
Faks +47 63 94 49 21
orders@aluflex.no
www.aluflex.no

item profiili oy
Mikkelänkallio 5
02771 Espoo
Puh +358 9 854 56 50
Fax +358 9 854 56 544
orders@itemprofiili.fi
www.itemprofiili.fi

www.aluflex.com